

## Built-in Circuit Type Ultra-miniature Piezoceramic Buzzer (Resin-sealed)

CPM121A0AWP is an ultra-miniature piezoceramic buzzer that uses a super-thin  $35\mu$  ceramic film.

It's a built-in circuit type, yet is only  $\phi 13.8 \times 7.5$  mm. This resin-sealed buzzer may be dip soldered.

We believe this buzzer will satisfy your needs for miniaturization of your products.

### Features

1. Ultra-miniature in cubic volume and light in weight.
  2. Low power consumption.
  3. Very clear electronic sound can be heard in the distance, even under noisy circumstances.
  4. No electric noise due to contacting parts; superior reliability and lifetime.
  5. Wide range of operating voltages (3~12V DC).
  6. Pin type enables easy mounting of buzzer on printed circuit boards.
  7. Suitable for dip soldering.
  8. Washable top-sealed buzzer is also available upon request.
  9. This buzzer conforms to EIAJ Standards.
- ※ EIAJ=Electronic Industries Association Japan.

### Specifications

Item code (EIAJ)	CPM121A0AWP (PB-RPD-C14-41)
Sound pressure	80dB min./10cm/DC12V
Oscillating frequency	$4.2 \pm 0.5$ KHz
Current consumption	8mA max./DC12V
Operating voltage	3~12V
Operating temperature range	$-20 \sim +70^{\circ}\text{C}$
Outside diameter	$\phi 13.8 \pm 0.2$ mm
Height	$7.5 \pm 0.2$ mm
Pin pitch	$7.6 \pm 0.2$ mm
Pin diameter	$\phi 0.7 \pm 0.1$ mm
Weight	1g
Case material	PPO(UL94V-1)



### Shape & Dimensions

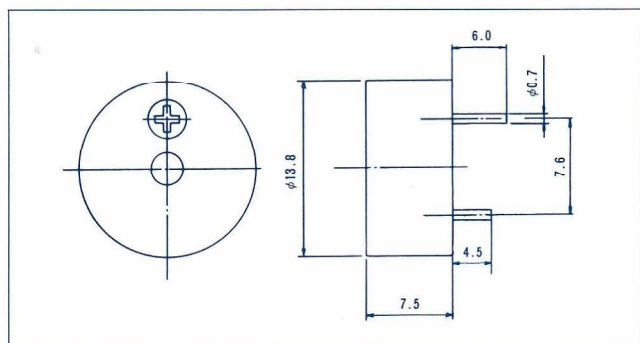

### ● Voltage-Sound Pressure · Current Consumption

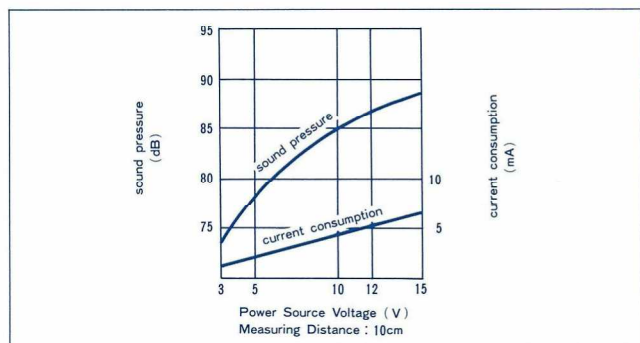

Specifications may be changed without notice.



**Megacera, Inc.**

Head Office · Factory : 7-5 Harajuku, Hidaka-City,  
Saitama 350-1205, Japan  
(PHONE) 0429-85-1111  
(FAX) 0429-89-7378

Date :20.Apr.2005

Drawing No.: A S - A \* \* \* \*

Messrs.

## APPROVAL SHEET

Model Name Piezoelectric Buzzer With Built-in Circuit

Parts No. C P M 1 2 1 A 1 A W P - S 0 1

Please sign one copy here, and return it to us by mail;  
Keep the other copy for your files.

7-5 HARAJUKU HIDAKA-SHI SAITAMA JAPAN  
ZIP CODE:350-1205 TEL:+81-429-85-1111  
FAX:+81-429-89-7378

**NIHON CERATEC CO., LTD.**  
**MEGACERA DIVISION**

Approved	Checked	Drawing

1 / 7

1 . Subject

This specification will apply to Piezoelectric Buzzer  
CPM121A1AWP-S01.

2 . Purchaser

2 . 1 Code NO.: \_\_\_\_\_

2 . 2 Part NO.: \_\_\_\_\_

3 . Supplier

3 . 1 Code NO. : \_\_\_\_\_

3 . 2 Part NO. :  C P M 1 2 1 A 1 A W P - S 0 1

4 . Scope

4 . 1 Appearance Dimensions

As per attached drawing No.  A S - A \* \* \* \* 7 / 7

4 . 2 Test Conditions

All measurements shall be made ambient temperature of  $25 \pm 5$   
and may also be permissible in between 5 ~ 35 relative humidity  
65% unless otherwise specified herein.

4 . 3 Electrical Characteristics

- (1)Sound Pressure Level : 81d B min. ( at 0.1m、 12VDC )
- (2)Oscillating Frequency (Fosc):  $4.2 \pm 0.5$  kHz
- (3)Current Consumption : 8 mA max
- (4)Operating Voltage : 3 ~ 15VDC
- (5)Operating Temp. : - 30 ~ + 80
- (6)Storage Temp. : - 30 ~ + 80
- (7)Operating Humidity : 80%RH max ( at 40 、 No condense )

NIHON CERATEC CO.,LTD.

Drawing NO. AS - A\*\*\*\*

2 / 7

## 5 . Test Method

### 5.1 Electrical Characteristics test method

ITEM	CONDITIONS
5.1 Sound Pressure Level & Oscillating Frequency	<div style="text-align: center;"> <p style="text-align: center;">Anechoic chamber</p> <p style="text-align: center;">10cm</p> <p style="text-align: center;">P.S.      P.B.      S.C.M.      S.P.L.M.      F.C.</p> </div> <p>P.S.; D.C. Power            P.B. ; Piezo Electric Buzzer            S.C.M.; Standard Condenser Microphone            S.P.L.M.; Sound Pressure Level Meter RION NA-40            F.C. ; Frequency Counter</p>

## 6 . Evaluation Testing

Test is done with JIS Z-9015-sampling plan for inspection by lot tolerance percent defective method.

	ITEM	METHOD	LEVEL	AQL
1	Appearance, Configuration	visual	S-3	0.65%
2	Sound Pressure Level	item 5.1	S-3	0.65%
3	Size	direct	n=5	(0.1)limit
4	Oscillating Frequency	item 5.1	S-3	0.65%

NIHON CERATEC CO.,LTD.

Drawing NO. AS - A\*\*\*\*

3 / 7

## 7 . Packing

Units shall be packed for shipping and storage so as not to be damaged, identifying by labeling with manufacture's name, part NO., lot NO. and quantity.

## 8 . Note

### 8 . 1 Caution in case of mounting and handling.

- (1) To prevent malfunctions, install the buzzer so that it does not come into contact with other components on its side or top surface.
- (2) There should not be any obstacle within 15mm from the top of the buzzer. Also , There should not be covered the sound opening with an adhesive tape or the like. If the sound hole is blocked, the buzzer may habit abnormal oscillation or stop functioning.
- (3) The buzzer can not be soldered by reflow. In case of reflow soldering, the case may be deformed.
- (4) Do not use the wrong polarity, If the buzzer is improperly connected, the internal circuit may break down when electricity is applied.
- (5) Use the buzzer within the operation voltage range. A higher voltage may damage the diaphragm and other components or cause a fire. With a lower voltage, the sound may not be produced.
- (6) Use a low-impedance(not more than 100 ) power supply for the buzzer; otherwise, the buzzer may exhibit abnormal oscillation or stop functioning.
- (7) The buzzer is built in complete circuit; so there is no need for another circuit for generating sound, Do not interpose a resistance in series between the buzzer and the power supply, because this will produce irregular oscillation.  
When resistor is necessary to control sound volume, use capacitor(1 $\mu$ F) parallel with the buzzer together.
- (8) Do not apply strong force to the pins before they are soldered. If the pins are bent or cut due to excessive force, the buzzer may not generate sound.

- (9) The installation position of the buzzer and acoustic impedance of the surrounding affect the sound. Please pay attention to appropriate setting.
- (10) Do not use the buzzer in a corrosive ambience, such as an ambience containing sulfur hydrides. Otherwise, a normal sound may not be generated due to corrosion of the components and diaphragm.
- (11) When washing, be sure that a solvent or the vapor of a solvent does not infiltrate the buzzer, so preventing deterioration and damage by the solvent trapped inside the casing.
- (12) Do not drop the buzzer.
- (13) Take special protective measures to prevent deterioration and breakdowns, whenever the buzzers are used in the following unfriendly areas:
- |                           |   |
|---------------------------|---|
| Dusty places              | Moist places                            |
| Hot or frosty places      | Humid places                            |
| Areas exposed to sunlight | Area exposed to solvents or their vapor |
- (14) When operating the buzzer outdoors, protect it from moisture to ensure normal operation.
- (15) The buzzer is intended for applying to personal computers, office automation units, communication units, audio-visual units, amusement units and other general household electrical appliances, no applying medical units, aeronautics units, space units and so on.

#### 8 . 2 Caution in case of storing

To prevent deterioration and breakdowns, do not store units in the following places:

- Dusty places
- Hot or frosty places.
- Areas exposed to sunlight
- Places with leaking or infiltrating water
- Humid places
- Areas exposed to solvents or their vapor
- Areas exposed to corrosive gases, such as H<sub>2</sub>S

	<b>NIHON CERATEC CO.,LTD.</b>	Drawing NO. AS - A****	5 / 7
--	-------------------------------	------------------------	-------

8 . 3 Other Precautions

- (1) Do not disassemble, repair or modify units, to maintain the initial performance and safety standard of it.
- (2) The products contain the lead so that the disposal of industrial wastes has to be required.

9 . General requirements :

- (1) In the case of different interpretation in this specification, discussions shall be made to agree each other.
- (2) With the worrying which exerts an influence on the efficiency being under for the material and the process change which is thought of, we make to cope after contacting(in the eye place of 2 months before) beforehand to you.

Appearance and dimensions (unit : mm)

Parts No. CPM121A1AWP-S01

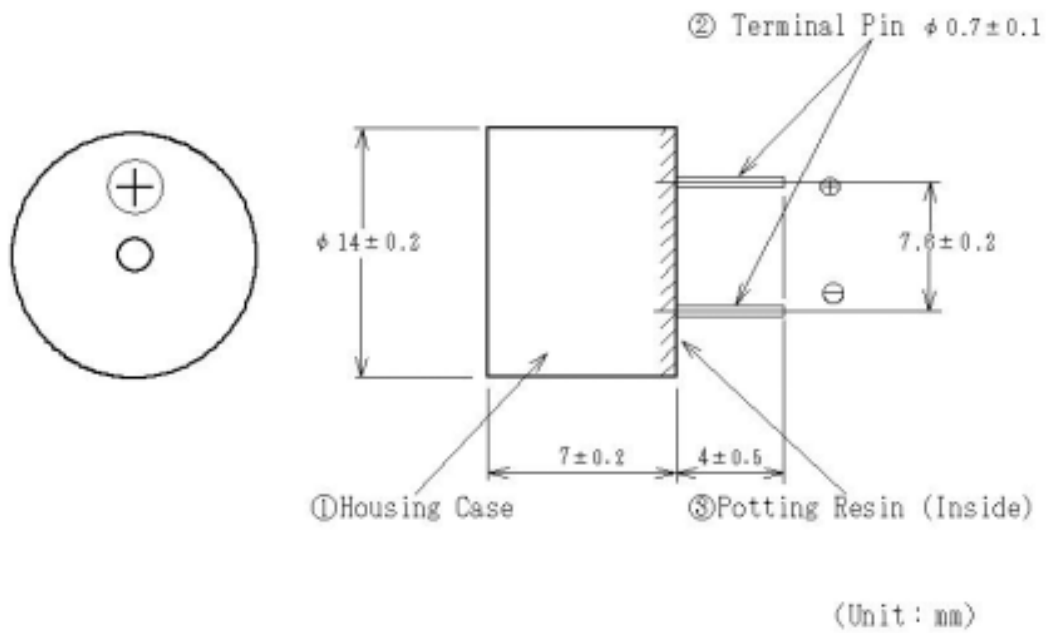

(1)Material

Case : PPO (BLACK)  
Terminal : Brass (Sn/Cu plated)  
Potting Resin: Epoxy resin (Black)

Polarity distinction

Polarity is indicated at the surface of the case. (+)

(2)Appearance

There are no remarkable dirt, crack and crack detrimental to a performance.

NIHON CERATEC CO.,LTD.

Drawing NO. AS - A\*\*\*\*

7 / 7