



## STH-S81-5020

### Ultrasonic Welding Transducer

#### APPLICATION

Ultrasonic Welding

#### FEATURES

- High Mechanical Quality
- Efficient Electro-Acoustics Conversion
- Large Output Amplitude
- Low Heat Generation

SPECIFICATIONS	
Resonant Frequency:	$F_r = 20 \pm 1 \text{ kHz}$
Resonant Resistance:	$R_o = \text{max. } 10 \Omega$
Capacitance:	$C_p = 9000 \text{ pF} \pm 10\%$
Bandwidth:	$\Delta f \geq 1 \text{ kHz}$
Insulation Resistance:	$R \geq 2000 \text{ M}\Omega$ with 2000VDC
Power (Instantaneous Power):	1000 W
Max. Input Voltage:	3000 Vp-p
Joint Bolt:	*M 16 x 2.0 mm (see note)
TEST METHOD & CONDITIONS	
Test Environment:	$23 \pm 3 \text{ }^\circ\text{C}$ ; 40 ~ 70% RH
Fr and Ro:	HP-4194 Impedance Analyzer
Capacitance:	LCR meter at 1 kHz, 1 Vrms

DRAWING

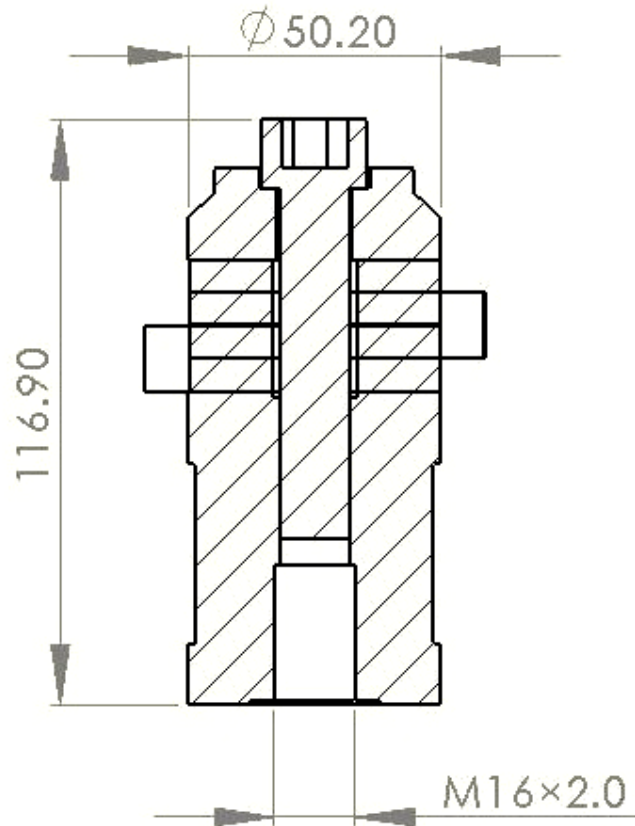

\* Size of joint bolt might be different as listed.