



PDUS200-PWR 200W Ultrasonic Driver

Manual and Specifications

PiezoDrive Pty. Ltd.

www.piezodrive.com

Contents

| | | |
|-------|---|----|
| 1 | Warnings / Notes | 3 |
| 2 | Specifications | 4 |
| 3 | Software Manual..... | 5 |
| 3.1 | Main Window | 5 |
| 3.1.1 | Overview | 5 |
| 3.1.2 | Status | 6 |
| 3.2 | Plot Windows | 6 |
| 3.2.1 | Graph Scale | 6 |
| 3.2.2 | Legend Position..... | 7 |
| 3.2.3 | Exporting Graph Data..... | 7 |
| 3.2.4 | Notes on Graph Functions | 7 |
| 3.3 | Manual Control Mode | 7 |
| 3.4 | Resonance Tracking Mode (Phase Tracking)..... | 8 |
| 3.5 | Resonance Tracking Mode with Power Control..... | 9 |
| 3.6 | Frequency Sweep Mode..... | 10 |
| 3.6.1 | Dynamic Range | 11 |
| 4 | Hardware Manual | 12 |
| 4.1 | Output Connection Diagram | 12 |
| 4.1.1 | LEMO Plug Cable Preparation..... | 13 |
| 4.1.2 | LEMO Plug Assembly..... | 13 |
| 4.2 | Overload Protection | 14 |
| 4.2.1 | Shutdown Indicator | 14 |
| 4.2.2 | External Shutdown..... | 14 |
| 4.2.3 | Enclosure..... | 14 |
| 5 | Installation | 15 |
| 6 | API Functions | 15 |

1 Warnings / Notes

- 1) This device produces hazardous potentials and should only be used by suitably qualified personnel under the supervision of an observer with appropriate first-aid training. Do not operate the device when there are exposed conductors.



2 Specifications

| Electrical | |
|-------------------|--|
| Frequency | 1 to 50 kHz (Pure Sine-wave) |
| Output Voltage | ± 100 V |
| Output Current | ± 4 A |
| Transducer Power | 200 W |
| Signal Bandwidth | 100 kHz |
| Slew Rate | 35 V/us |
| Gain | 15 V/V |
| Overload | Thermal and over current protection |
| Analog Outputs | Voltage and current monitors |
| Analog Inputs | Signal input (± 7.5 V) Auxiliary monitor input (± 10 V) |
| Output Connectors | LEMO 0B Socket 4mm Banana Sockets |
| Power Supply | 90 Vac to 250 Vac |

| Mechanical | |
|-------------|---|
| Environment | -40 to 60°C (-40 to 140°F) Non-condensing humidity |
| Dimensions | 212 x 304.8 x 88 mm |
| Weight | 2 kg |

| Digital | |
|----------------------|-----------------------------|
| USB | USB 2.0 |
| Frequency Resolution | 1 mHz |
| Phase Resolution | 0.1 Degrees |
| Sampling Rate | 1 MHz |
| Available Signals | Voltage, current, auxiliary |
| Amplifier Shutdown | USB or Digital (Via BNC) |

3 Software Manual

3.1 Main Window

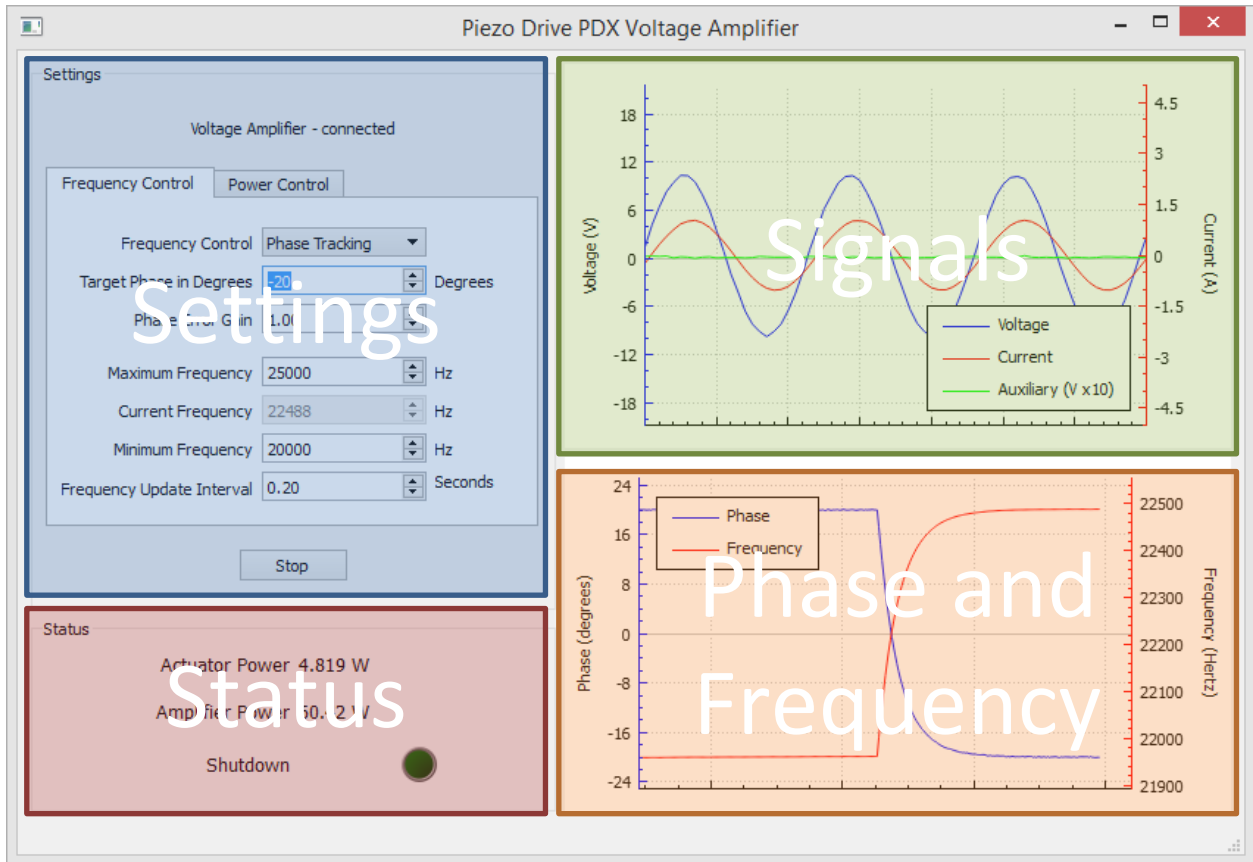

Figure 1. Main software window

The main window is comprised of four sections, the

- Settings control panel,
- Amplifier status panel,
- Signal waveforms graph, and
- Phase and frequency graph.

3.1.1 Overview

The amplifier is controlled by the settings control panel, which is comprised of the mode selection boxes, the numeric parameters, and the Start/Stop button. The available settings depend on the mode and whether the amplifier is running.

Most of the settings can be controlled by multiple input methods:

- clicking the controls in the widget
- the up, down, page up, and page down keyboard keys
- the mouse scroll wheel
- numeric text input.

3.1.2 Status

The Status section of the Main Window reports the power being dissipated by the actuator and the amplifier, and the amplifier shutdown indicator.

Actuator Power

The Actuator Power is calculated by

$$P_{act} = \frac{1}{N} \sum_{n=0}^N (v_n - V_{av}) \times (i_n - I_{av})$$

where v_n and i_n are the samples of voltage and current and V_{av} and I_{av} are the average (DC) values. N is chosen to include an integer number of the waveform periods.

The amplifier power is calculated by

$$P_{amp} = P_{total} - P_{act}$$

where P_{total} is

$$P_{total} = V_s \times I_s$$

where V_s is the total supply voltage (200V) and I_s is supply current which is calculated by averaging the rectified output current

$$I_s = \frac{1}{N} \sum_{n=0}^N |i_n|$$

Shutdown

The shutdown indicator is activated when the amplifier has entered a shutdown state due to a current overload or when the temperature of the amplifier exceeds 100 °C (212 °F). In the shutdown state, the amplifier output is switched to high-impedance.

3.2 Plot Windows

The user can interact with the plot windows with a number of controls.

3.2.1 Graph Scale

The scale of an axis can be controlled by clicking it then moving the mouse scroll wheel. The limits of the axis can also be adjusted by clicking and dragging. To de-select an axis, the user can left-click on the graph area. The graphs auto-scale by default but this is disabled once the user has made a manual adjustment. To re-enable autoscaling the user can double click the axis to enable auto-scaling.

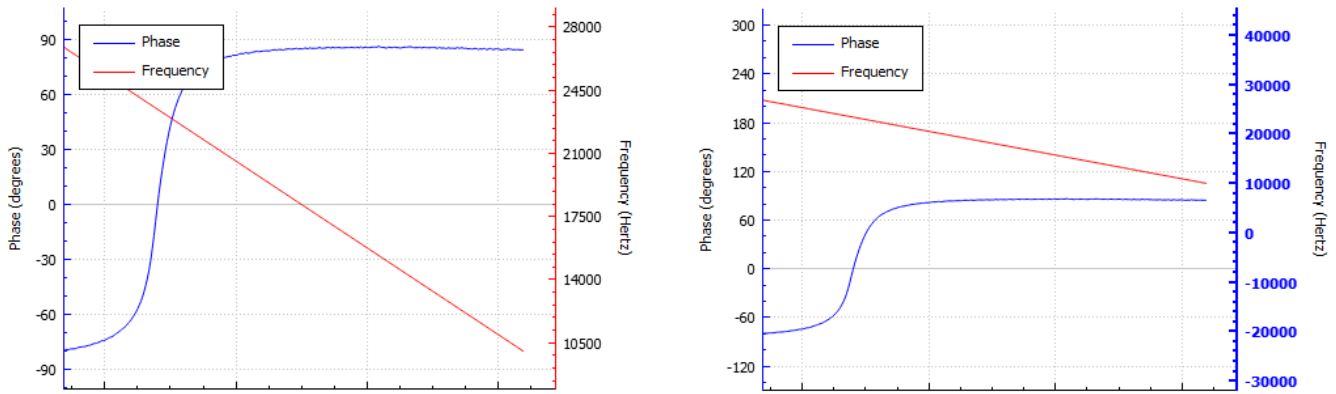

Figure 2. An example where the scale and offset of the phase and frequency plot is manually controlled

3.2.2 Legend Position

To adjust the legend position, right-click the legend and select a new position.

3.2.3 Exporting Graph Data

To export a graph, right-click the graph area select either 'Save as PDF' or 'Save as CSV', then select the file location.

3.2.4 Notes on Graph Functions

- The x-axis of the Phase and Frequency graph is fixed and cannot be selected or adjusted.
- Auto-scaling is not disabled for the Actuator Impedance or Auxiliary Transfer Function graphs while the sweep is active. The graph is auto-scaled until the sweep is complete.

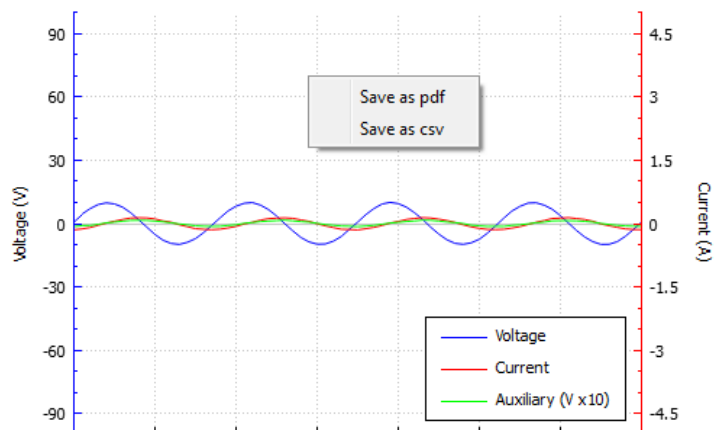

3.3 Manual Control Mode

The amplifier operates in manual mode when the Frequency Control is set to "Manual" and the Power Control is set to "fixed amplitude". In this mode the amplifier generates a sine wave output with the amplitude and frequency set in the settings control panel. The controls that are available in this mode are:

- **Driving Amplitude Peak to Peak** controls the peak-to-peak voltage of the drive signal. It can take integer values between 0V and 200V.
- **Maximum Frequency** controls the frequency limits of the Current Frequency and can be set between the 10 kHz and 100 kHz. If this value is adjusted below the Current Frequency, the Current Frequency is adjusted to comply with the Maximum Frequency setting.
- **Current Frequency** can be set to an integer value between the Minimum Frequency and Maximum Frequency.

- **Minimum Frequency** can be set to an integer value between 1 kHz and the Maximum Frequency. If this value is adjusted above the Current Frequency, the Current Frequency is adjusted to comply with the Minimum Frequency.
- **Power.** If the power dissipated in the actuator is greater than this value, the actuator power reading in the status panel changes to bold red text to alert the user.
- **Start/Stop button.** Enables/disables the signal generator.

The above settings can be adjusted whether the amplifier is stopped or started. The user can also switch between Test Signal and Resonance Tracking when the amplifier is stopped or started.

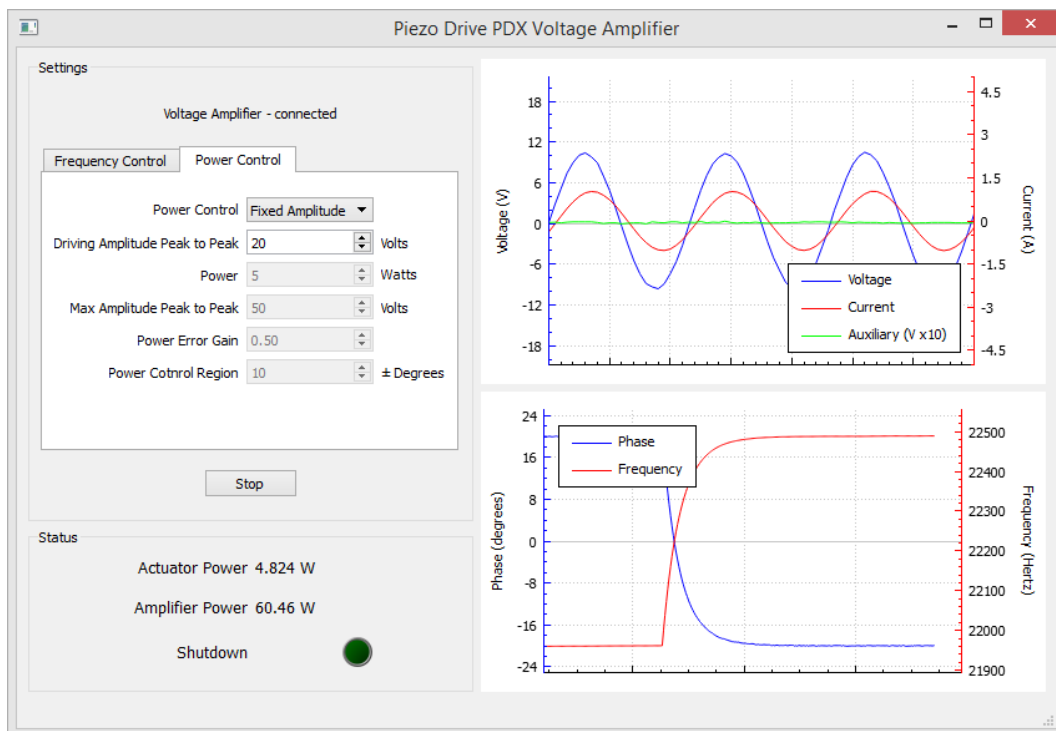

Figure 3. Manually controlled frequency and amplitude

3.4 Resonance Tracking Mode (Phase Tracking)

Resonance tracking is achieved by setting the Frequency Control to “Phase Tracking”. In this mode the amplifier adjusts the frequency of the drive voltage to maintain a constant phase between the drive voltage and current. All of the controls described above are available in resonance tracking mode, with the addition of:

- **Frequency Step** controls the rate of change in the frequency adjustment. The next frequency is calculated by

$$f_{k+1} = f_k + \text{Freq. Step} \times (\text{Target Phase} - \text{Current Phase})$$

High values of Frequency Step cause the drive frequency to adjust more quickly but may be less stable. The Frequency Step can be set between 0.01 and 10.0.

- **Target Phase** of the current relative to the drive voltage. This is equivalent to the phase of the admittance, which is the inverse of impedance. Negative values indicate a current lag (inductive), and positive values indicate a current lead (capacitive)
- **Frequency Update Interval** sets the minimum amount of time that the amplifier will wait between frequency updates. Longer intervals allow the transient response to settle before the next phase measurement, at the expense of update rate.

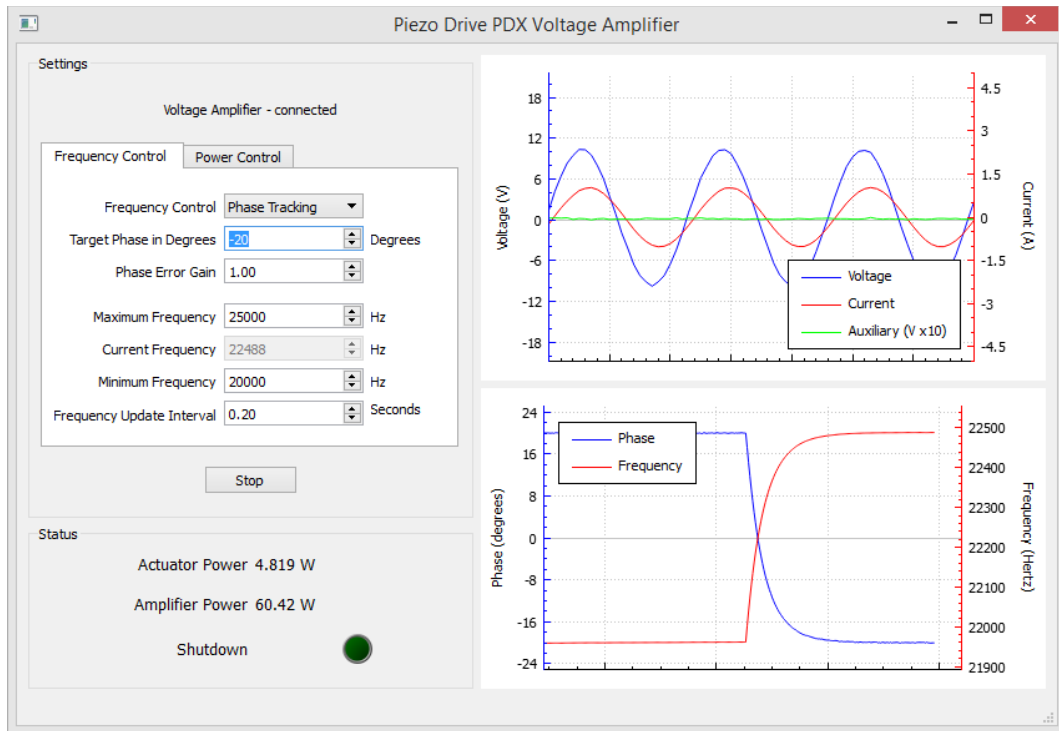

Figure 4. Resonance tracking using phase control and fixed amplitude

3.5 Resonance Tracking Mode with Power Control

In addition to resonance tracking, the applied voltage can also be controlled to achieve a constant actuator power dissipation. This mode is entered by setting Power Control to “Power Tracking”. The additional settings in this mode are:

- **Power** is the desired real power dissipation in the actuator.
- **Power Error Gain** sets the rate at which the voltage is adjusted. The useful range is between 0.1 and 10. A value of 0.5 is recommended during initial testing.
- **Power Control Region** sets the phase range where the power control is active. The power control is only active when the phase error of the resonance tracking is less than the numeric value (in degrees). That is, the resonance tracking function occurs first; then the power is controlled when the phase error is less than 10 degrees (default value).

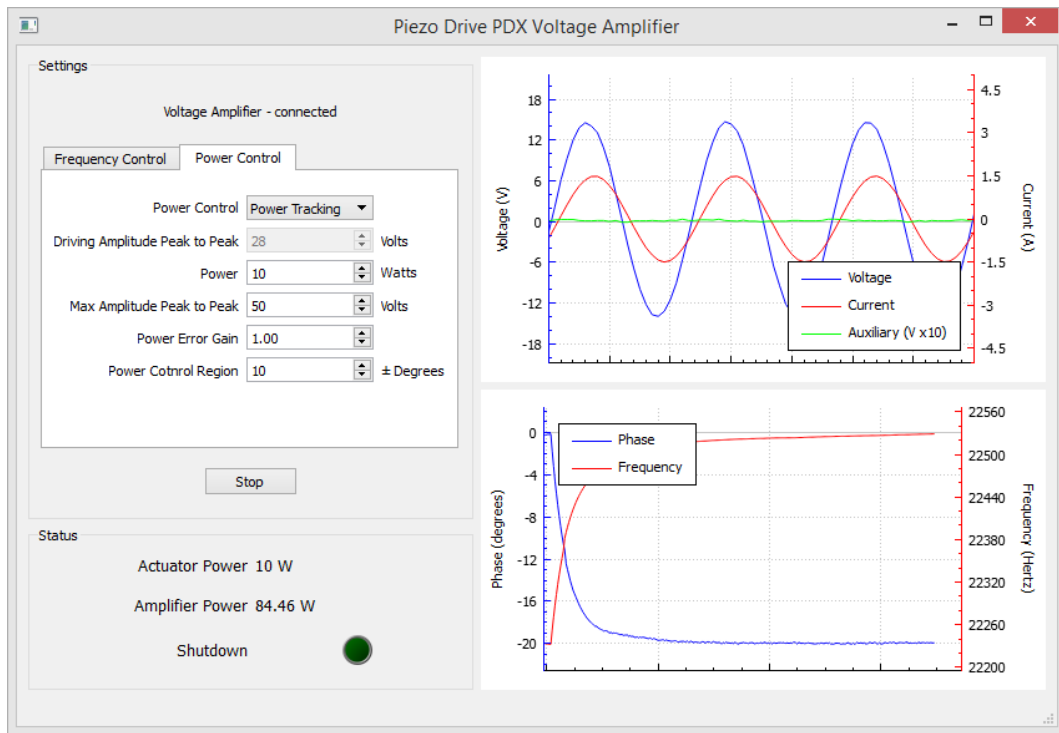

Figure 5. Resonance control with power tracking

3.6 Frequency Sweep Mode

In the frequency sweep mode, the impedance of the transducer is measured from the set Minimum to Maximum frequency. Since many ultrasonic actuators exhibit a non-linear resonance at high-power, the frequency is swept in both directions. 500 points are recorded in both directions; therefore the resolution is controlled by the Maximum and Minimum Frequency. During the frequency sweep, there is a fixed 200 ms delay between measurements to allow for the decay of transients between frequency changes, this results in 5 measurements per second and a total sweep time of 200 seconds.

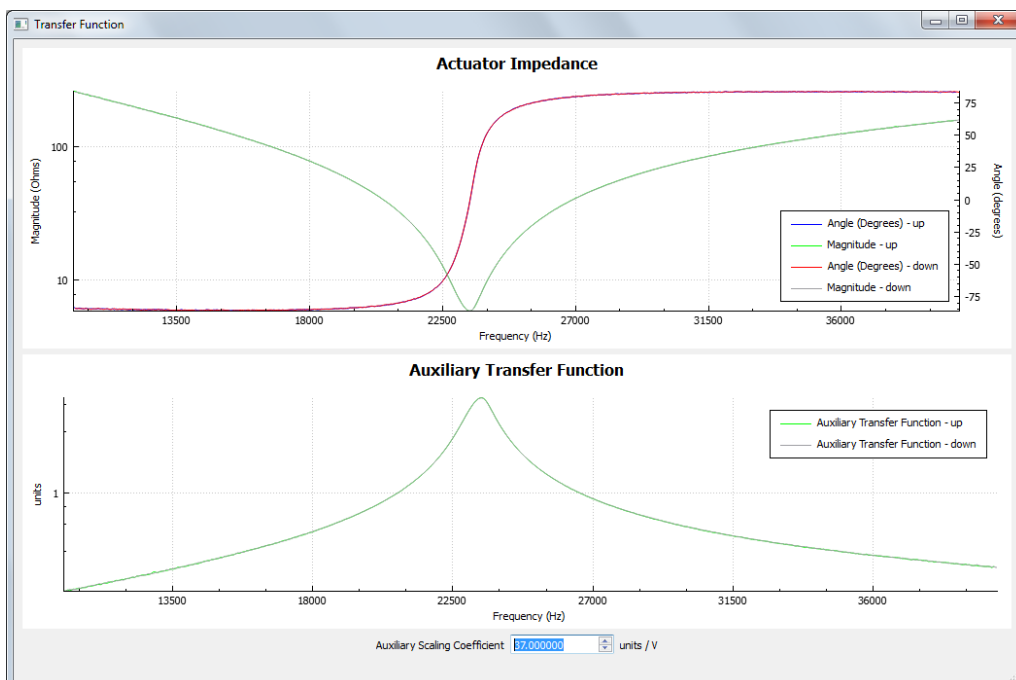

Figure 6. The frequency sweep window

In the Frequency Sweep mode, the available controls are:

- Driving Amplitude Peak to Peak
- Maximum Frequency
- Minimum Frequency
- Start/Stop button.

In addition to the impedance measurement, the transfer function between the voltage and an auxiliary signal can also be measured simultaneously by applying an auxiliary signal to the front panel. Typical signals include the acceleration, velocity, or displacement. A scaling coefficient is available below the Auxiliary Transfer Function plot which allows the vertical scale to be equated to the sensor gain.

3.6.1 Dynamic Range

The dynamic range of the frequency response measurement is 12-bit relative to the full-scale range of the current measurement, which is ± 5 Amps. Therefore, the minimum detectable current is ± 3 mA.

Furthermore, in order to allow grounded transducers, the internal current measurement is performed on the “high-side” of the load which is subject to a large common-mode signal. The common-mode rejection ratio of the current measurement is approximately -80 dB at 100 kHz. This may also limit the detection of small currents when large voltages and high frequencies are encountered.

Due to the limited dynamic range, the PDUS200 will not accurately measure anti-resonances in the impedance transfer function where very little current is flowing. Precise measurement of the system anti-resonances are best performed using a shunt resistor to ground and a dedicated spectrum, or network analyzer.

The minimum detectable signal in the auxiliary transfer function is ± 5 mV.

4 Hardware Manual

4.1 Output Connection Diagram

The actuator can be connected to the amplifier by either two 4mm banana plugs or a 2-way LEMO 0B socket (LEMO EGG.0B.302.CLL). Preassembled LEMO cable assemblies are available from www.PiezoDrive.com

The mating plug is a LEMO 0B 2-Way Straight Cable Plug. Ordering details and specifications are listed below. These parts can be obtained directly from www.mouser.com

| | |
|-------------------------------|-----------------------------------|
| Plug | LEMO 0B 2-Way Straight Cable Plug |
| Crimp Terminal Version | *LEMO FGG.0B.302.CYCZ |
| Solder Tag Version | LEMO FGG.0B.302.CLAZ |
| Max Conductor Size | AWG22 |

| | |
|-----------------------|---------------|
| Cable Collet | FGG.0B.742.DN |
| Cable Diameter | 3.1mm – 4mm |

| | |
|---------------------------|---------------------------------|
| Strain Relief Boot | GMA.0B.035.DN (3.5–3.9mm Cable) |
|---------------------------|---------------------------------|

*The crimp terminal plug requires a tool, if this is not available, the solder tag plug should be used.

A two conductor cable is required to connect the amplifier to a transducer. A recommended cable is the Belden 8451 cable. The specifications are listed below.

| | |
|-------------------------|--|
| Cable | Belden 8451 |
| Conductor Size | AWG22 (0.64mm diameter) |
| Resistance | 53 mOhms/m |
| Capacitance | 115 pF/m core-core, 220 pF/m core-shield |
| Outside Diameter | 3.5mm |

The actuator wiring diagram is shown below.

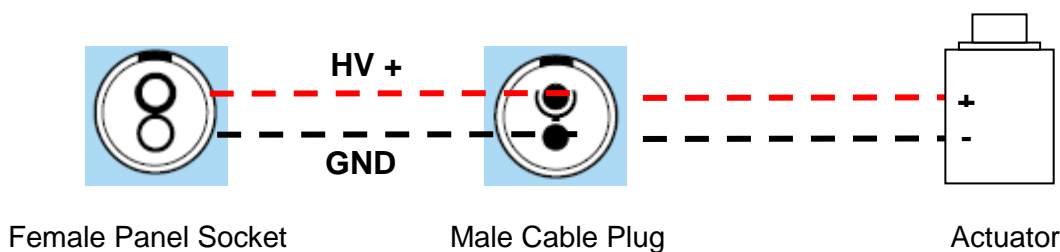

4.1.1 LEMO Plug Cable Preparation

(Taken from LEMO OB Series Cable Assembly Instructions)

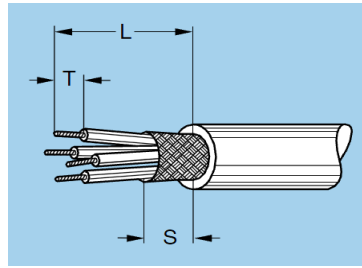

| Solder | | | Crimp | | |
|--------|---|-----|-------|---|-----|
| L | S | T | L | S | T |
| 13.0 | 7 | 3.0 | 17.0 | 7 | 4.0 |

4.1.2 LEMO Plug Assembly

(Taken from LEMO B Series Cable Assembly Instructions)

1. Strip the cable as above
2. If the cable is shielded, fold the shield back over the cable
3. Slide the strain relief, collet nut (1) and collet (3) onto the cable.
4. Solder or crimp the conductors onto the contacts.
5. Assemble the plug,

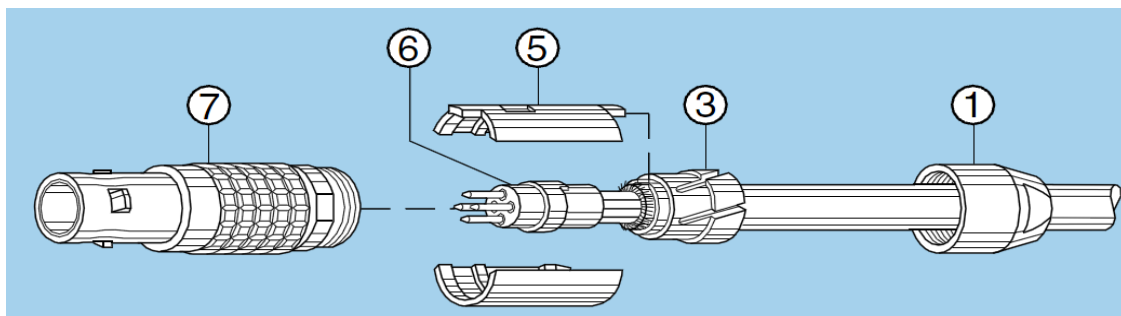
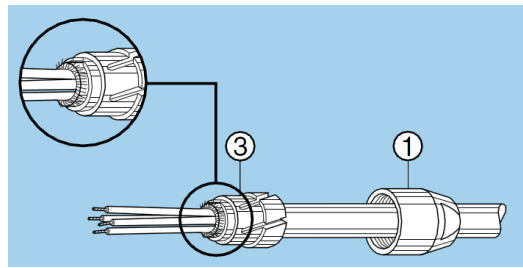

4.2 Overload Protection

4.2.1 Shutdown Indicator

The Shutdown indicator will illuminate during a shutdown caused by a current overload or if the amplifier overheats as a result of excessive ambient temperature, poor air-flow, or fan failure.

During shutdown, the amplifier output current is limited to a few mA and may float to the high or low voltage rail if the load impedance is high.

When the amplifier is turned on, the overload protection circuit is engaged by default and will take approximately three seconds to reset.

4.2.2 External Shutdown

In addition to the internal shutdown triggers, the output stage of the amplifier can also be disabled by applying a positive voltage to the external shutdown connector (2V to +12V).

The impedance of the external shutdown input is approximately 2.5 k Ω .

4.2.3 Enclosure

The PDUS200 Driver has a side air intake and rear exhaust. These vents should not be obstructed. If sufficient air-flow is not available, the amplifier will enter a thermal overload state as discussed above.

The PDUS200 amplifiers can be bolted together in a side-by-side two-channel arrangement. With the addition of rack-mount handles, this configuration can be mounted into a standard 19-inch rack. A 19-inch rack-mount kit is also available for a single amplifier.

5 Installation

The PDUS200 desktop software is straight-forward to install and remove. Simply copy the program folder to a convenient location, for example, the desktop; then open the application “PDUS200.EXE”. If desired, a shortcut can be created by right clicking PDUS200.EXE and selecting “Create Shortcut”, this shortcut can be placed on the desktop or dragged into the start menu.

The USB drivers are plug-and-play, no installation is necessary.

6 API Functions

All of the amplifier functions can be controlled from any Windows application by utilizing the PDUS200 Application Programming Interface (API). The API is a DLL file which provides functions for controlling the amplifier and reading the status and signals. The documentation and program files for the API can be obtained by contacting info@piezodrive.com

The desktop software for the PDUS200 uses the API so the source code is a useful programming example. This is included in the API package.