

Magnifying / Demagnifying the motion

Mechanical Transformer

Piezoelectric actuator incorporated with Mechanical Transformer

M e c h a T r a n s [®]



Mechano Transformer Corp.

For A Better Tomorrow

01. Introduction of MechaTrans[®]

We provide mechanical transformer that mechanically controls motion through magnification demagnification.

We design and tailor made the MechaTrans[®] based on customer needs...

The advantages of the Mechanical Transformer

- Capable in precision positioning
- Compact / slim in size
- Competence in durability
- Potential to reduce total number of parts required

The advantages of the multilayer stacked piezoelectric actuator

- High mechanical-electrical conversion efficiency
- High speed response
- Compact / slim in size
- High controllability

Mechanical Transformer



Multilayer stacked piezoelectric actuator



MechaTrans[®]

The advantages of MechaTrans[®]

- 1) Capable to perform in less than 1ms
- 2) Capable to be arrange in less than 2mm pitches
- 3) Capable to operate above 1 billion cycles
- 4) Capable to achieve energy saving due to high energy conversion efficiency
- 5) Unlike solenoid, energy consumption for maintaining a displacement is less.
- 6) Capable to achieve high repeatability in precise positioning

MechaTrans[®] VS Solenoids

*Cost reduction is possible through mass productions

MechaTrans [®]	○	○	○	△	△	○	○	○	○	○	△	△*
Solenoids	×	×	×	○	○	×	×	×	×	×	○	○
	High output force	Precise positioning	Speedy response	Low voltage driven	Adaptability in high humidity environments	Energy conversion efficiency	Energy conversion in maintaining an output stroke	Compact / slim in size	High Controllability	Free from electro-magnetic emission	High output stroke	Cost

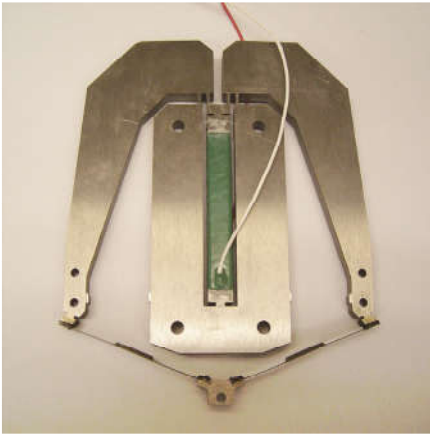

● Table 2

(unit : mm)

Type	Item	t 1	t 2	h	w	a	b	c	Fixed Screw	Drive Screw
MTA01S50F1	1	1.9	32	26	10.4	7	9.8	φ2	φ2	
MTA01S100F0.6	1	1.9	32	26	10.4	7	9.8	φ2	φ2	
MTA01S200F0.3	1	1.9	32	26	10.4	7	11.3	φ2	φ2	
MTA02S50F5	2	3.5	28	25	10.4	7	9.7	φ2	φ2	
MTA02S100F2	2	3.5	31	30	10.4	7	9.7	φ2	φ2	
MTA02S200F1	2	3.5	33	35	10.4	7	9.7	φ2	φ2	
MTA02S100F4	2	3.5	46	43	13	14	13	φ3	φ2	
MTA02S200F2	2	3.5	42	43	13	14	13	φ3	φ2	
MTA02S400F1	2	3.5	46	48	13	14	13	φ3	φ2	
MTA02S200F4	2	3.5	63	58	15	24	18	φ3	φ2	
MTA02S400F2	2	3.5	55	58	15	24	13	φ3	φ2	
MTA02S600F1	2	3.5	62	58	15	24	18	φ3	φ2	
MTA02S400F7	2	3.5	81	58	15	44	13	φ3	φ2	
MTA02S600F5	2	3.5	83	58	15	44	13	φ3	φ2	
MTA02S800F3	2	3.5	79	58	15	44	13	φ3	φ2	
MTA05S100F13	4.8	8	53	52	16	19	13.5	φ3	φ2	
MTA05S200F10	4.8	8	51	50	16	19	13.5	φ3	φ2	
MTA05S400F3	4.8	8	55	50	16	19	14	φ3	φ2	
MTA05S200F12	4.8	8.6	65	58	16	26	15	φ3	φ2	
MTA05S400F9	4.8	8.6	61	58	16	24	15	φ3	φ2	
MTA05S600F4	4.8	8.6	65	58	16	24	15	φ3	φ2	
MTA05S400F26	4.8	8.6	86	67	18	44	17	φ3	φ2	
MTA05S800F13	4.8	8.6	86	67	18	44	17	φ3	φ2	
MTA05S1600F5	4.8	8.6	91	77	20	50	15	φ3	φ2	
MTA10S200F43	9.4	14.2	75	75	26	29	17.8	φ4	φ2	
MTA10S400F29	9.4	14.2	75	75	26	29	17.8	φ4	φ2	
MTA10S700F14	9.4	14.2	75	83	26	29	17.8	φ4	φ2	
MTA10S400F74	9.4	14.2	96	77	26	49	17.8	φ4	φ2	
MTA10S800F37	9.4	14.2	96	77	26	49	17.8	φ4	φ2	
MTA10S1600F18	9.4	14.2	97	89	26	49	17.8	φ4	φ2	

● Table 1

Type	Item	Displacement [μ m]	Generative force [N]	Stiffness [N/ μ m]	Capacitance [μ F]
MTA01S50F1	75	1.4	0.028	0.026	
MTA01S100F0.6	150	0.6	0.006		
MTA01S200F0.3	300	0.3	0.0016		
MTA02S50F5	75	5	0.074	0.09	
MTA02S100F2	150	2	0.017		
MTA02S200F1	300	1	0.004		
MTA02S100F4	150	4	0.043	0.18	
MTA02S200F2	300	2	0.011		
MTA02S400F1	600	1	0.003		
MTA02S200F4	300	4	0.017	0.35	
MTA02S400F2	600	2	0.005		
MTA02S600F1	900	1	0.0015		
MTA02S400F7	600	7	0.017	0.82	
MTA02S600F5	900	5	0.008		
MTA02S800F3	1200	3	0.004		
MTA05S100F13	150	13	0.132	0.75	
MTA05S200F10	300	8	0.037		
MTA05S400F3	600	3	0.007		
MTA05S200F12	300	12	0.049	1.4	
MTA05S400F9	600	8	0.021		
MTA05S600F4	900	4	0.007		
MTA05S400F26	600	27	0.057	3.4	
MTA05S800F13	1200	16	0.017		
MTA05S1600F5	2400	5	0.003		
MTA10S200F43	300	43	0.228	5.4	
MTA10S400F29	600	28	0.071		
MTA10S700F14	1050	14	0.019		
MTA10S400F74	600	64	0.148	13.6	
MTA10S800F37	1200	37	0.043		
MTA10S1600F18	2400	18	0.011		

● Figure 1 Outline of important parameters

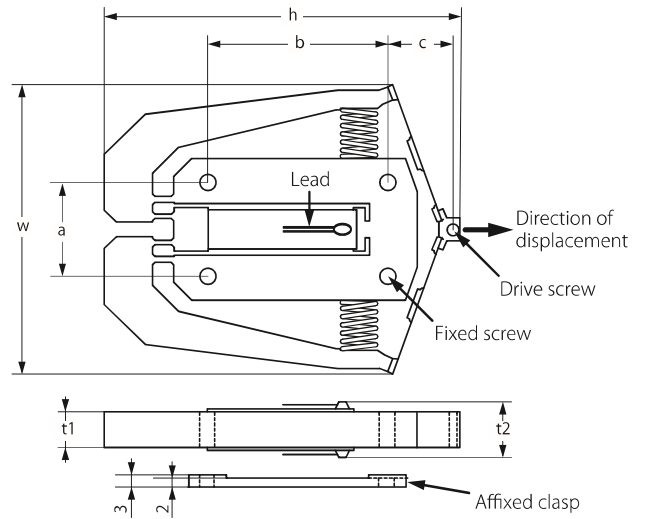

● Figure 2 Displacement Vs Output Force

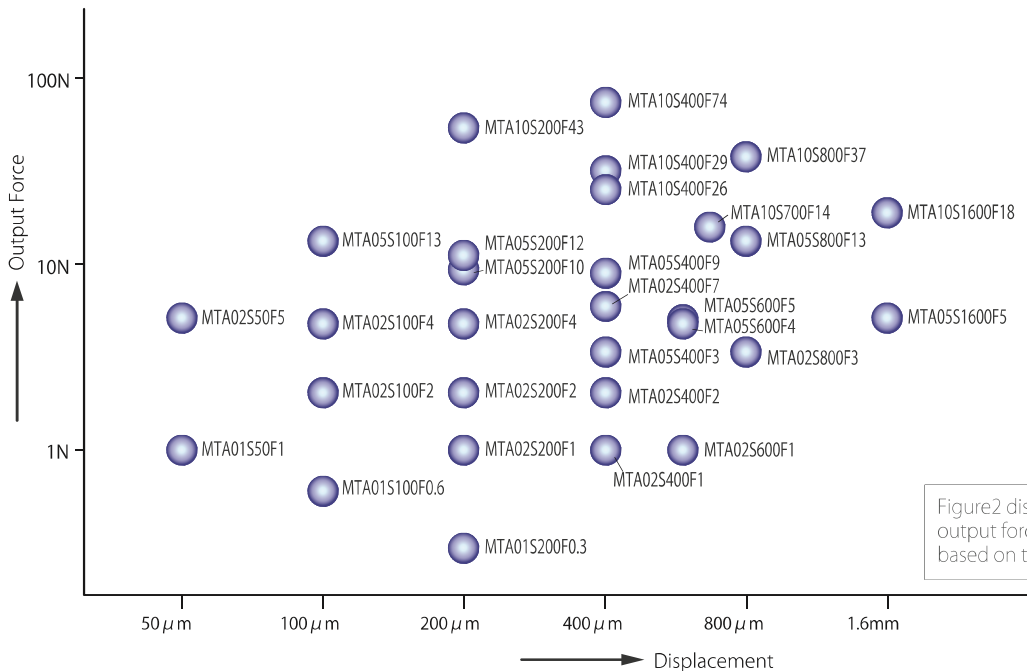

※Please refer to Table2 for the dimensions of all corresponding parameters

Figure2 displays the relationship between displacement and output force of the MechaTrans. Please select the MechaTrans based on the necessary output force and displacement.

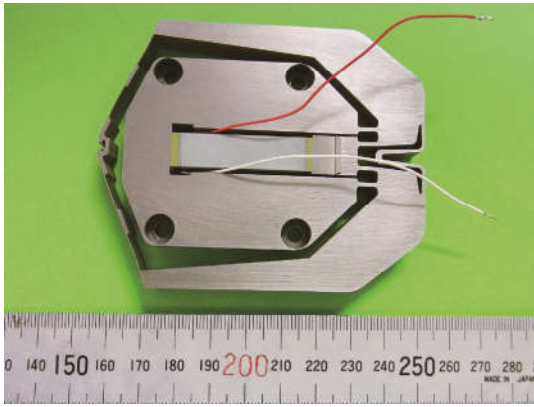

- Displacement of 1400 μm at 150V
- Output force above 90N at 150V
- Fast rise time of 1.3ms

[Voltage Vs Displacement]

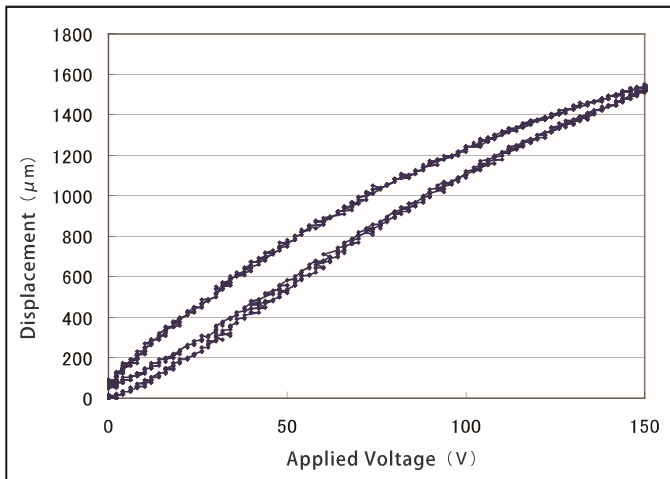

[Voltage Vs Blocked force]

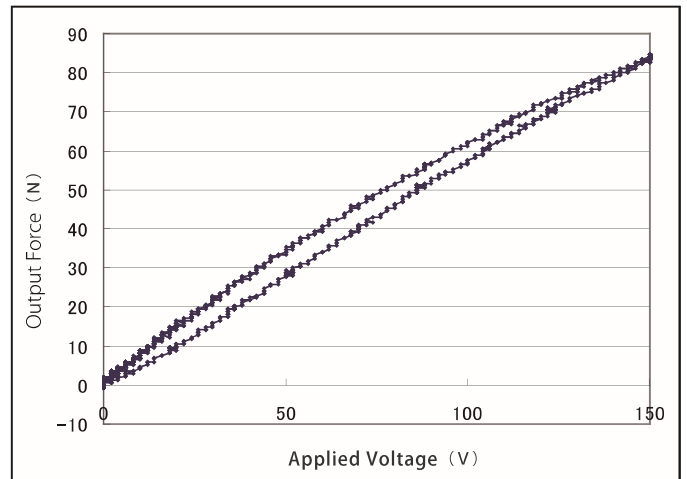

[Rise time waveform]

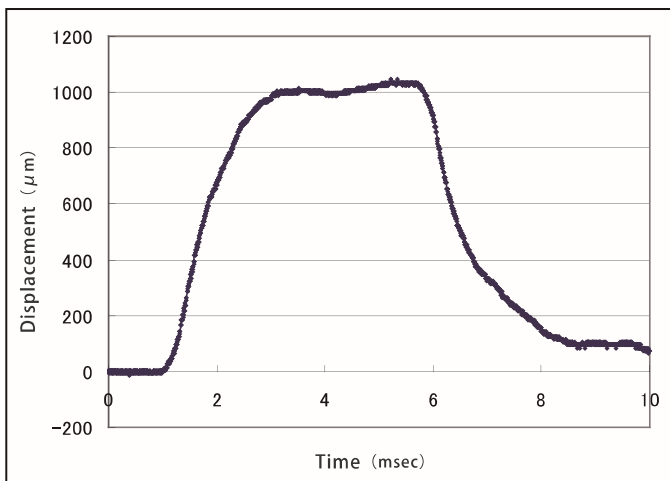

Type	Item	Dimension[mm] W×D×H	Displacement [μm]	Generative force [N]	Stiffness [N/ μm]	Resonance frequency [Hz]	Capacitance [μF]
	MTAU10S1100F100	80×10×96	1100	100	0.09	400	31.5
	MTAU10S1400F90	79×10×94	1400	90	0.06	400	24.9

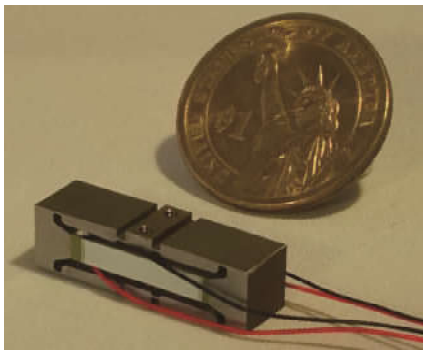

MechaTrans® MTDD Series

- Compact and thin
- Output stroke perpendicular to the output stroke the piezoelectric actuator
- Variety of choices for selection.

Type	Item	Dimension[mm] W×D×H	Displacement [μm]	Generative force [N]	Stiffness [N/μm]	Resonance frequency [Hz]	Capacitance [μF]
MTDD03S50F3		15×3×5	50	3	0.06	1500	0.03
MTDD04S90F5		25×4×13	90	5	0.06	700	0.37
MTDD06S100F10		20×6×7	100	10	0.10	700	0.20
MTDD06S100F11		20×6×7	100	11	0.11	900	0.36
MTDD08S300F16		26×8×7	300	16	0.05	460	0.70
MTDD08S350F18		26×8×8	350	18	0.05	500	0.80
MTDD16S750F90		52×16×14	750	90	0.12	230	8.00

MechaTrans® MTN Series

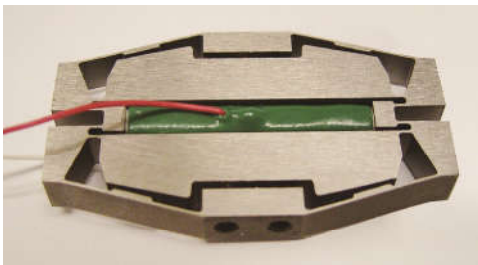

- Compact and thin
- Output stroke perpendicular to the output stroke the piezoelectric actuator
- Variety of choices for selection.

Type	Item	Displacement [μm]	Generative force [N]	Stiffness [N/μm]	Resonance frequency [Hz]	Capacitance [μF]
MTN03S50F4		80	4	0.08	1046	0.18
MTN04S130F5		200	5	0.03	417	0.35
MTN12S1000F113		1150	83	0.11	106	21.6



<Application of MTN Series>
3-Axis Stage

MechaTrans® MTD Series

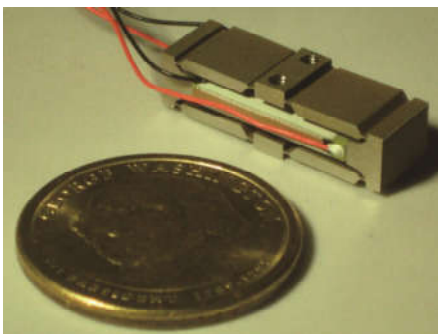

- Compact and thin
- Output stroke of the MechaTrans D series is perpendicular to the output stroke the piezoelectric actuator
- Output stroke direction is opposite to the MechaTrans N series
- Variety of choices for selection.

Type	Item	Dimension[mm] W×D×H	Displacement [μm]	Generative force [N]	Stiffness [N/μm]	Resonance frequency [Hz]	Capacitance [μF]
MTD03S50F3		15×5×3	50	3	0.06	2000	0.03
MTD08S250F27		22×8×8	250	27	0.11	790	0.85
MTD08S300F25		26×8×8	300	25	0.08	500	0.85
MTD16S750F90		50×16×16	750	90	0.12	290	8.5

02. Application of MechaTrans[®]

We have many kinds of MechaTrans (Amplified/Magnified piezo actuator) ranges from small sizes to the large displacement or the high output force.

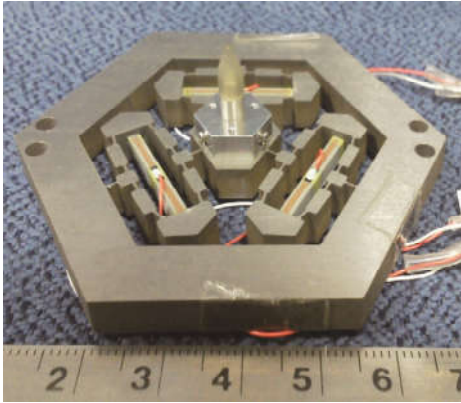

1

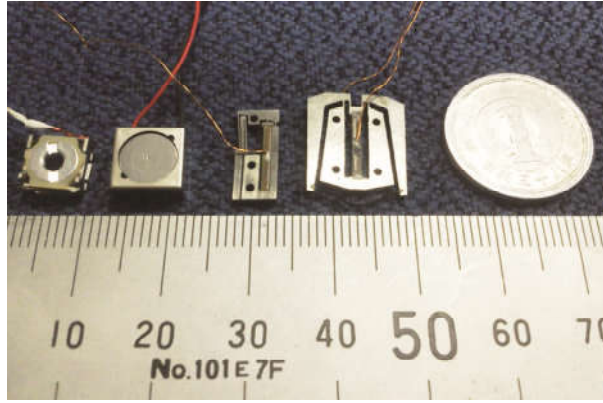

2

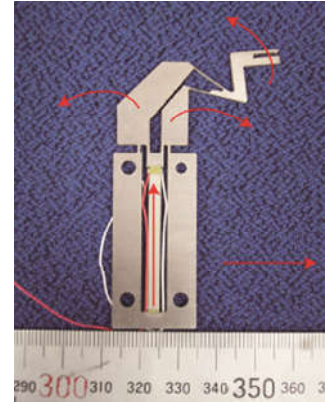

3

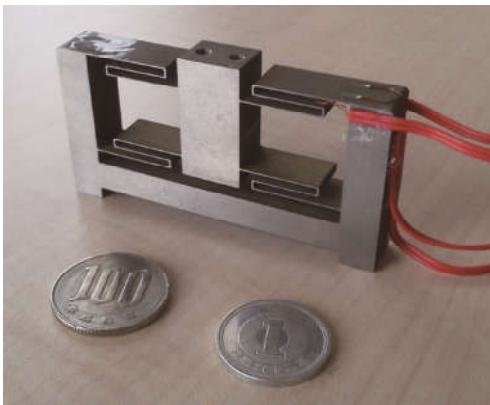

4

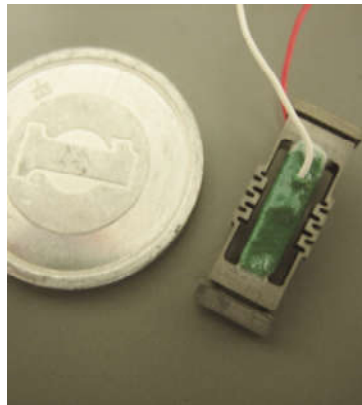

5

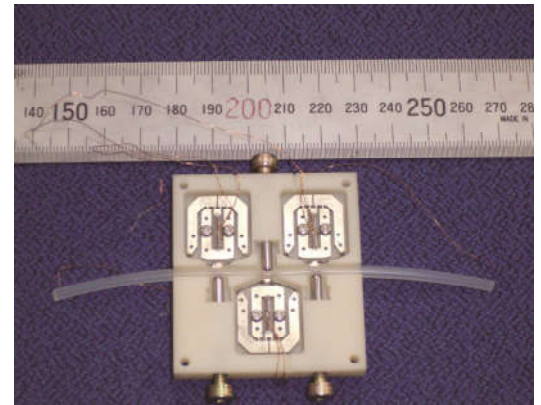

6

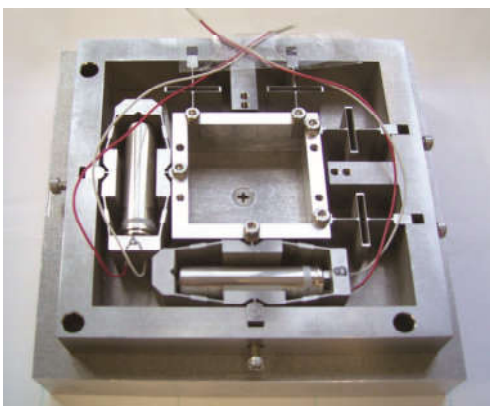

7

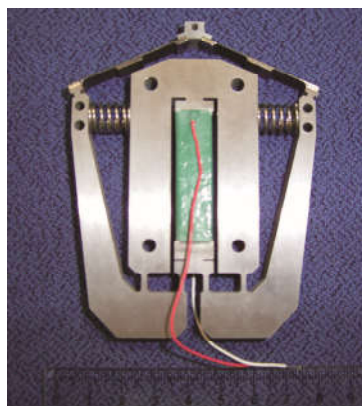

8

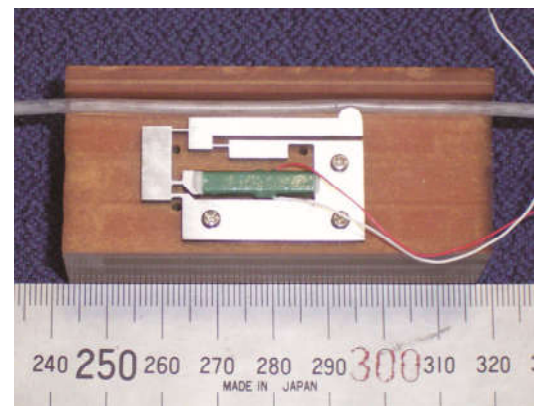

9

1. MechaTrans driven polisher for precision polishing
2. Micro type MechaTrans (A joint development project with Namiki Precision Jewel Co. Ltd.)
3. Fast angle tilting MechaTrans (Capable to be arranged in 2 mm pitches)
4. Micro-weight loader and detector
5. MechaTrans with pressurized mechanical structure
6. MechaTrans driven tubular pump
7. Precision XY stage
8. High speed puncher for ceramic sheets (A product developed for Howa Machinery Co. Ltd.)
9. On / Off pump

03. The taylor made MechaTrans[®]

We can tailor the MechaTrans (Amplified/Magnified piezo actuator) such as modified the travel length, the sizes, the mechanical interface and etc, based on your requirements.

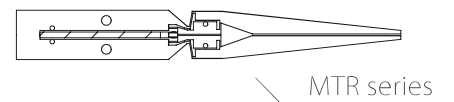
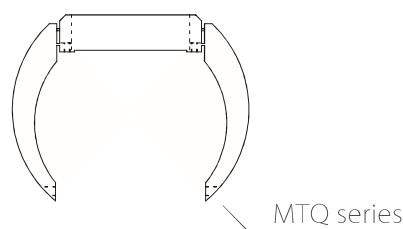
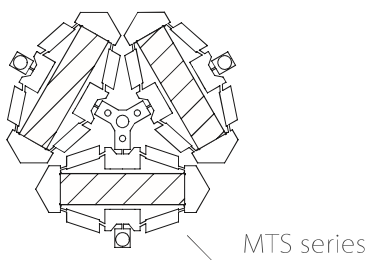
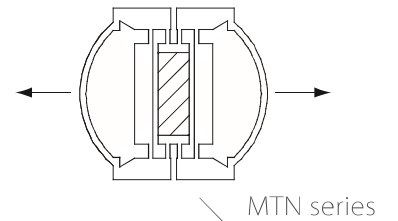
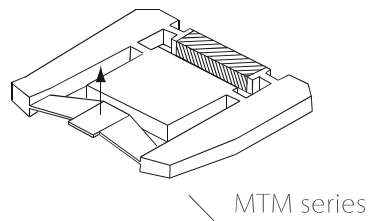
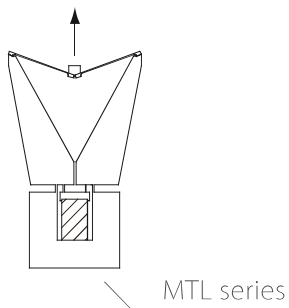
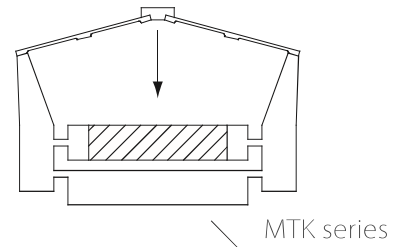
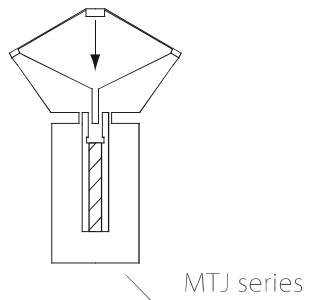
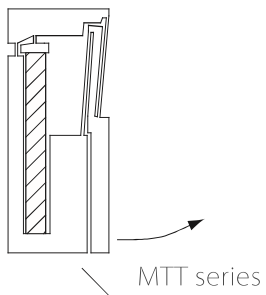
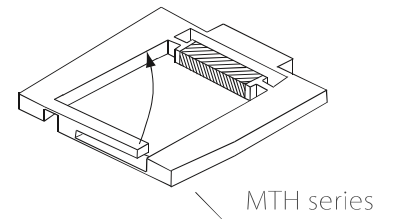
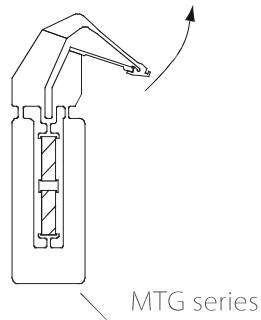
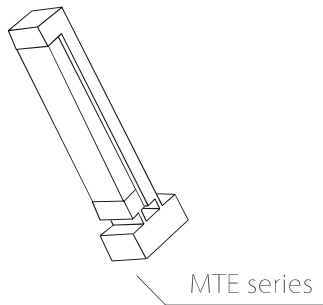
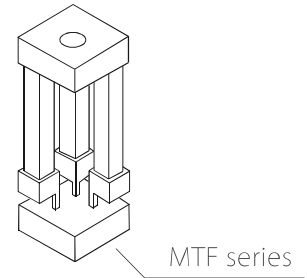
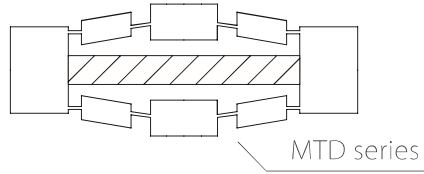
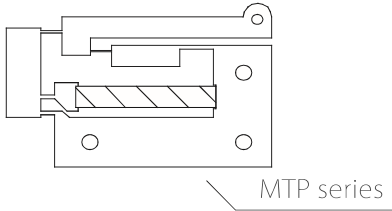

The MTG, MTH, MTT, MTJ, MTK, MTL, MTM and MTN series are abstracted from "The front line research and development of actuators". (Toshiro Higuchi, Masahiro Ooka, Section 7, Chapter 1, 2nd Edition of the NTS' August 8th 2011 publication)

04. The Multilayer Stacked Piezoelectric Actuator

We provide solutions for installation of the multilayer stacked piezoelectric actuator in mechanical structure

Have you ever face the following problems with multilayer stacked piezoelectric actuator

- Hard to handle
- Easily broken
- Displace not according to specification
- Cannot fix with screws
- Adhesion issues



We can tailor to your needs

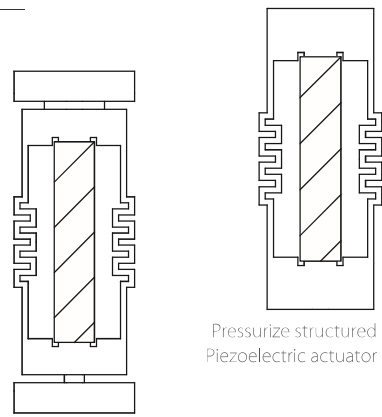

Pressurize structure with flexure hinges for piezoelectric actuator

*The dimensions are based on clients' request

The Multilayer stacked piezoelectric actuator (by NEC TOKIN)

Features

- Highly responsive
- High conversion efficiency from electrical to mechanical energy (approx. 60%)
- High mechanical energy generation per unit volume (approx. 20 mJ per 1 cm³)
- High output force (approx. 3500N per 1 cm² of cross sectional area)
- Good energy source for mechanical transformer

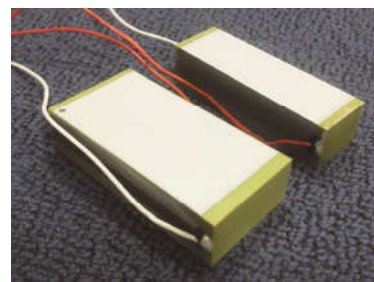

Please feel free to consult us if you are facing any adhesive issues

A table of standard products

Product	Item	Applied Voltage 150V (Max.)			Applied Voltage 100V (Rec.)			Resonant Frequency (kHz)	Electrostatic Capacitance (μF)
		Displacement (μm)	Force (N)*	Energy (mJ)*	Displacement (μm)	Force (N)	Energy (mJ)*		
AE0203D04DF		4.6±1.5	237	0.55	3.0±1.5	155	0.23	261	0.09
AE0203D08DF		9.1±1.5	235	1.07	6.1±1.5	157	0.48	138	0.18
AE0203D16DF		17.4±2.0	224	1.95	11.6±2.0	150	0.87	69	0.35
AE0203D44H40DF		42.0±6.6	271	5.69	28.0±6.6	181	2.53	34	0.82
AE0505D08DF		9.1±1.5	978	4.45	6.1±1.5	656	2.00	138	0.75
AE0505D16DF		17.4±2.0	935	8.14	11.6±2.0	624	3.62	69	1.4
AE0505D44H40DF		42.0±6.6	1129	23.7	28.0±6.6	753	10.5	34	3.4
AE1010D16DF		18.4±3.5	3956	36.4	12.3±3.5	2645	16.3	69	5.4
AE1010D44H40DF		42.0±6.6	4515	94.8	28.0±6.6	3010	42.1	34	13.6
AE1414D16DF		18.4±3.5	7754	71.3	12.3±3.5	5183	31.9	69	10.8
AE2525D15DF		15.6±2.0	21000	163.5	10.1±2.0	13600	68.5	69	30.5
AE1020D44H40DF		42.0±6.6	9030	189.6	28.0±6.6	6020	84.2	34	27.2
AH10x12.5D50H40DF		48.5±6.6	6517	158.0	32.3±6.6	4345	70.2	34	27.0

Note: *The value was calculated based on the displacement value and Young's modulus

The Adhesion of the Multilayer stacked piezoelectric actuator

With years of experience in the adhesion of multilayer piezoelectric actuators with mechanical transformer, we are ready to assist you in your inquiries. Besides, we provide the epoxy bonding resin in small volumes. For more information on our adhesives, please feel free to contact us.



Cautions!

- 1) Heat expansion coefficient need to be considered when applying the epoxy bonding resin.
- 2) Heating time of epoxy bonding resin depends on the size of MechaTrans and the jigs.
- 3) Do not over apply the epoxy at the multilayer piezoelectric actuator.

Driving method of the multilayer piezoelectric actuator

We provide consultancy in driving the multilayer piezoelectric actuator based on the desired motion. A proper driving method can achieve the following merits.

- 1) Short rising and falling time
- 2) Achieve almost zero residue vibrations

Driving example

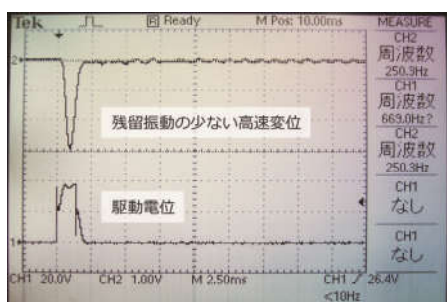

1) Driving method with very little residual vibration



2) Repetitive drive
Displacement : 300 μ m/Cyclic frequency: 250Hz

Voltage Driven Piezo Driver / Piezo control system MT-SYS1001

» Voltage Driven Piezo Driver



MTAD1004

- Gain: 20 x
- Output range: -20V~+150V
- Average current: 40mA
- Drive target: Stacked Piezoelectric, Bimorph, unimorph
- Dimension: W100 x D95 x H35mm(size for case)
- Power supply: AC adapter attached



MTAD1010

- Gain: 15 x
- Output range: 0V~+150V
- Average current: 100mA
- Drive target: Stacked Piezoelectric, Bimorph, unimorph
- Dimension: W53 x D220 x H124mm
- Power supply: AC100V



MTAD1100

- Gain: 15 x
- Output range: 0V~+150V
- Average current: 1A
- Drive target: Stacked Piezoelectric, Bimorph, unimorph
- Dimension: W103 x D220 x H124mm
- Power supply: AC100V



MTAD3002

- Gain : 50 x
- Output range : -20V ~ +150V
- Average current : 2A
- Drive target : Stacked Piezoelectric, Bimorph, unimorph
- Example application :
Precision stage, pump, air valve, AutoFocus Actuator
- Dimension : W360xD300xH185mm
- Power supply : AC100V



MTAD3003

- Gain : 50 x
- Output range : -20V ~ +150V
- Average current : 3A
- Drive target : Stacked Piezoelectric, Bimorph, unimorph
- Example application :
Precision stage, pump, air valve, AutoFocus Actuator
- Dimension : W440xD350xH185mm
- Power supply : AC100V

» Piezo control system MT-SYS1001

Outline : Piezo control system (MT-SYS1001) is the most basic element to form a piezo control system.
With the MT-SYS1001, customer can make their system setup easily and speedy.

System architecture: 1. Computer 2. Control module 3. Piezo driver

*Option : Based on customer needs, sensor or many kinds of control modules can be add on.

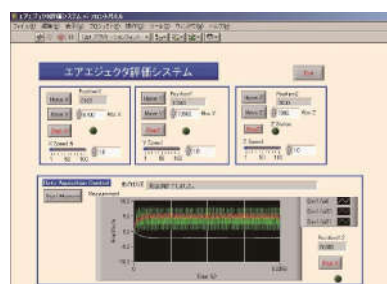

Control panel



Hardware

Preload structured piezoelectric actuator

» The advantages of the preload structured piezoelectric actuator

— Enhancing reliability of the multilayer stacked piezoelectric actuator

The multilayer stacked piezoelectric actuator can be so lasting when is well designed but can be so fragile when the design work is insufficient.

One the reason is the multilayer stacked piezoelectric actuator must be used under a preload conditions due its tension failure is so low which is 1/10 of its blocked (output) force.

If a multilayer stacked piezoelectric actuator is well design with preload, its life cycles can be more than 5 billions cycles.

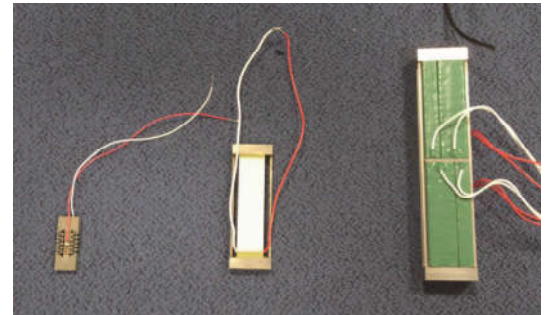

— Easy to handle

It is quite tricky sometimes to utilize a multilayer stacked piezoelectric actuator. When the design works is not sufficient, then the output stroke become less. You need some know how to fully utilize it. Here, with the preload structured piezoelectric actuator, we guarantee you the performance of the multilayer stacked piezoelectric actuator. Besides, there are taps machined in the preload mechanical structure, you can easily connect it to your experiment setup easily with screws. As the preload structured piezoelectric actuator is only connected to your experiments setup with screws, you can change it easily if there is a necessity. The multilayer stacked piezoelectric actuator will be more robust in your experiments setup when it is case in the preload mechanical structure.

Tailor made your own piezoelectric actuator

The are only several standard sizes of the multilayer stacked piezoelectric actuator in the market. When one need to use a different output performance of the multilayer stacked piezoelectric such as output stroke more than $100\ \mu\text{m}$, one have to order made from the manufacturer. However, it may be highly cost and time consuming to the process. Sometimes the manufacturers do not even supply such long stroke piezoelectric actuator. Therefore, we propose a preload structured piezoelectric actuator that can be tailor based on your needs. We can combine the multilayer piezoelectric actuator in series or in parallel in order to achieve performance you need. Figure of PTK10S90 shows an example of a long strokes preload structured piezoelectric actuator

■ Long stroke preload structured piezoelectric actuator (PTK10S90)

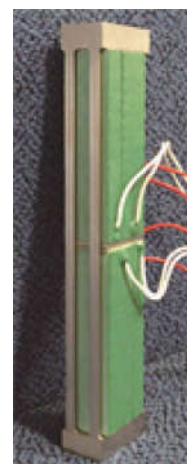

Dimension: 14 x 19 x 91mm
Output stroke: $100\ \mu\text{m}$ (-20V~150V)

Piezo Assist Precision stage

» MTPA1000

Features:

- Easy manual positioning at 20nm resolution
- Fine adjustment range of 60 μm
- Coarse adjustment range of 13mm
- Suitable for optical alignment and cell manipulation
- Low cost
- Easy setup



■ Evaluation data on resolution

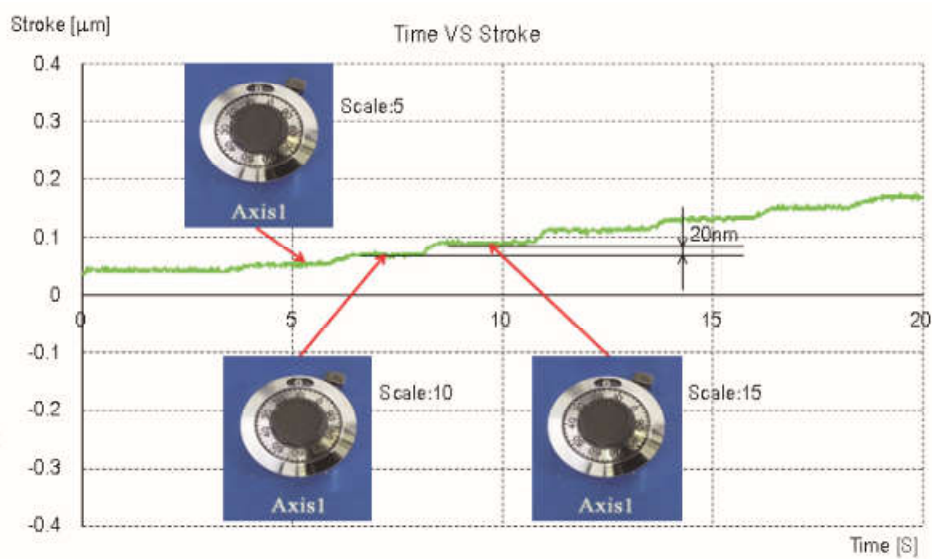

■ Evaluation data on repeatability

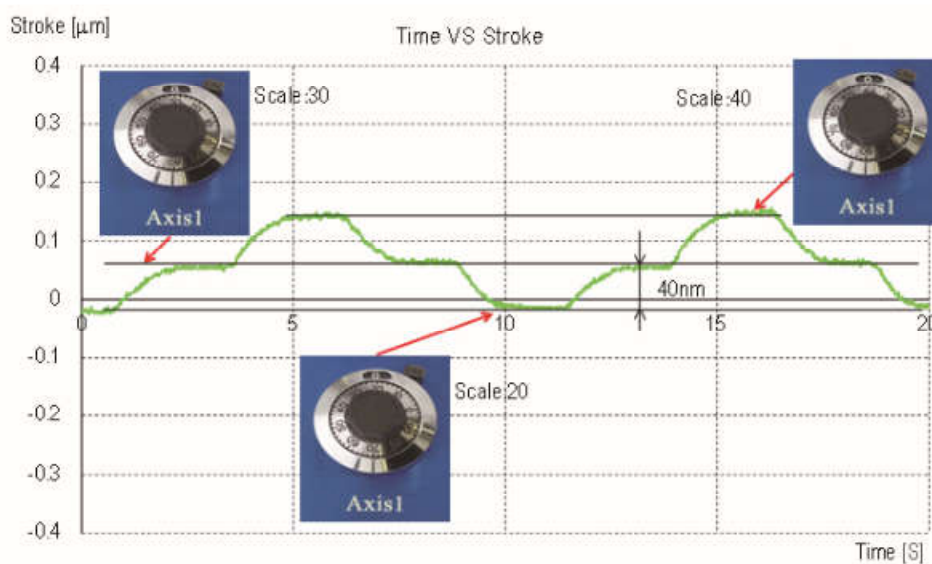

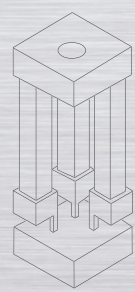
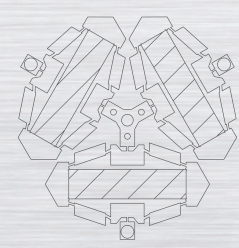
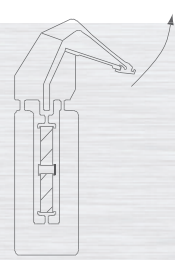
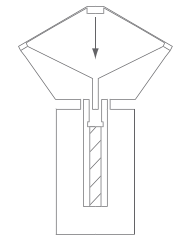
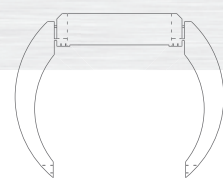
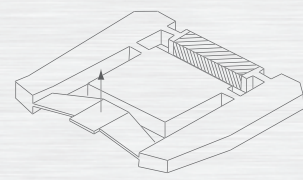
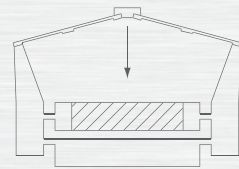

Contact Us



+81-352976088



+81-352976089



info@mechano-transformer.com



有限会社 メカノトランスフォーマ

Mechano Transformer Corp.

About us

Company Name : Mechano Transformer Corp.

President : Chee Sze Keat

Capital : ¥10 million

Head Office : 4F BUILDX No.3,

2-7-12, Iwamoto-cho, Chiyoda-ku, Tokyo, 101-0032 Japan

History

The establishment of Denshi Seiki Co. Ltd. at Shinagawa Ward, Tokyo in May, 2002

The relocation to our current address at KBIC, the replacement of the company name to Mechano Transformer Corp. and the acceptance of the Kawasaki Entrepreneur Award for Excellence in May, 2005.

The approval to obtain the SME Support Growth Grant by the Organization for SME and Regional Innovation, Japan in May 2006.