

NAC2124-Hxx



Noliac ring stack actuator NAC2124-Hxx (height in mm - Hxx) is based on the multilayer actuator NAC2124 and can be stacked to match your requirements. The standard range of NAC2124-Hxx is produced in a height between 4-150 mm. The ring stack provides a stroke in a range between 3.3 and 244.2 μm and blocking force up to 4750 N depending on the height of the stack.

SPECIFICATIONS

Attributes	Value	Tolerance
Length / outer diameter	15 mm	+0.65/-0.45 mm
Width / inner diameter	9 mm	+0.30/-0.50 mm
Max width / outer diameter max	16.8 mm	
Height	4 — 150 mm	+/-0.2 mm or 1% (whichever is largest)
Operating voltage, max.	200 V	
Free stroke, max.	3.3 — 244.2 μm	+/- 15%
Blocking force, max.	4750 N	+/-20%
Capacitance	460-33950 nF	+/- 15%
Stiffness	1439-19 N/ μm	+/-20%
Maximum operating temperature	150 °C	
Material	NCE51F	
Unloaded resonance frequency	>248k - 7 k Hz	
Electrodes	Screen-printed Ag and soldered bus wire (option: glued connections)	

Stack options

Height	Stroke	Capacitance
4 mm	3.3 μm	460 nF
6 mm	6.6 μm	920 nF
8 mm	9.9 μm	1380 nF
10 mm	13.2 μm	1840 nF

12 mm	16.5 μm	2300 nF
14 mm	19.8 μm	2750 nF
16 mm	23.1 μm	3210 nF
18 mm	26.4 μm	3670 nF
20 mm	29.7 μm	4130 nF
22 mm	33 μm	4590 nF
24 mm	36.3 μm	5050 nF
26 mm	39.6 μm	5510 nF
28 mm	42.9 μm	5970 nF
30 mm	46.2 μm	6430 nF
32 mm	49.5 μm	6890 nF
34 mm	52.8 μm	7340 nF
36 mm	56.1 μm	7800 nF
38 mm	59.4 μm	8260 nF
40 mm	62.7 μm	8720 nF
42 mm	66 μm	9180 nF
44 mm	69.3 μm	9640 nF
46 mm	72.6 μm	10100 nF
48 mm	75.9 μm	10560 nF
50 mm	79.2 μm	11020 nF
52 mm	82.5 μm	11480 nF
54 mm	85.8 μm	11930 nF
56 mm	89.1 μm	12390 nF
58 mm	92.4 μm	12850 nF
60 mm	95.7 μm	13310 nF
62 mm	99 μm	13770 nF
64 mm	102.3 μm	14230 nF
66 mm	105.6 μm	14690 nF
68 mm	108.9 μm	15150 nF
70 mm	112.2 μm	15610 nF
72 mm	115.5 μm	16070 nF
74 mm	118.8 μm	16520 nF
76 mm	122.1 μm	16980 nF
78 mm	125.4 μm	17440 nF
80 mm	128.7 μm	17900 nF
82 mm	132 μm	18360 nF
84 mm	135.3 μm	18820 nF
86 mm	138.6 μm	19280 nF
88 mm	141.9 μm	19740 nF
90 mm	145.2 μm	20200 nF
92 mm	148.5 μm	20660 nF
94 mm	151.8 μm	21110 nF
96 mm	155.1 μm	21570 nF
98 mm	158.4 μm	22030 nF
100 mm	161.7 μm	22490 nF
102 mm	165 μm	22950 nF
104 mm	168.3 μm	23410 nF
106 mm	171.6 μm	23870 nF

108 mm	174.9 μm	24330 nF
110 mm	178.2 μm	24790 nF
112 mm	181.5 μm	25250 nF
114 mm	184.8 μm	25700 nF
116 mm	188.1 μm	26160 nF
118 mm	191.4 μm	26620 nF
120 mm	194.7 μm	27080 nF
122 mm	198 μm	27540 nF
124 mm	201.3 μm	28000 nF
126 mm	204.6 μm	28460 nF
128 mm	207.9 μm	28920 nF
130 mm	211.2 μm	29380 nF
132 mm	214.5 μm	29840 nF
134 mm	217.8 μm	30290 nF
136 mm	221.1 μm	30750 nF
138 mm	224.4 μm	31210 nF
140 mm	227.7 μm	31670 nF
142 mm	231 μm	32130 nF
144 mm	234.3 μm	32590 nF
146 mm	237.6 μm	33050 nF
148 mm	240.9 μm	33510 nF
150 mm	244.2 μm	33970 nF

DRAWINGS

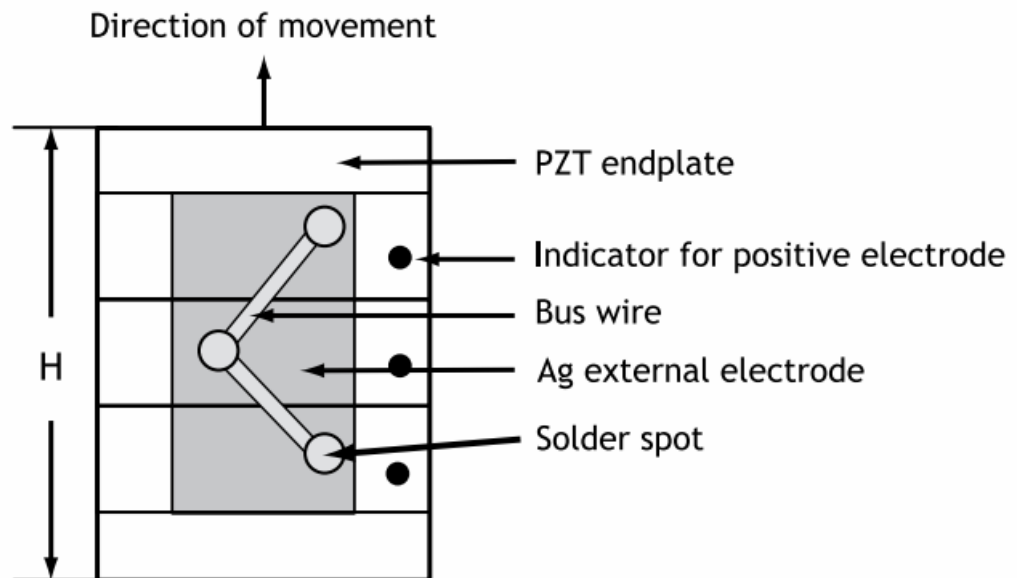
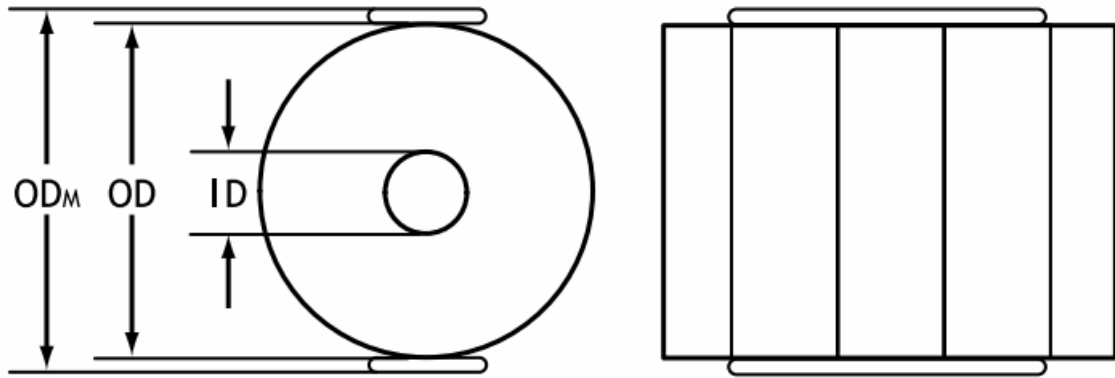

MOUNT AND CONNECT

Mounting

The actuators are usually grinded on top and bottom surfaces (perpendicular to the direction of expansion) in order to obtain flat and parallel surfaces for mounting. The actuators may be mounted either by mechanical clamping or gluing.

Avoiding short circuit can either be achieved by:

- Adding Kapton foil on the metallic surfaces.
- Having inactive ceramic plates between the actuator and the metal plate.
- Stacked actuators are manufactured with top and bottom insulating ceramic end-plates.

If glued, it is important to ensure a very thin glue line between the actuator and the substrate. It is recommended that a pressure, e.g. 2-5 MPa, is applied during the curing process.

To avoid significant loss of performance, the mounting of the actuators should avoid mechanical clamping and/or gluing on the sides of the actuator.

During manufacturing or handling, minor chips on the end-plates can appear. Minor chips cannot be avoided, but such chips do not affect performance.

Electrical connection

External electrodes

The external electrodes are screen printed silver as standard. Other materials, e.g. gold or silver/palladium are available on request. The positive electrode is indicated by a black spot.

Electrical connection to the external electrodes can be achieved by mechanical contacts, soldering, gluing with electrically conductive glues or wire bonding.

Mechanical connections

Mechanical connections can be arranged by e.g. copper springs contacted to the external electrodes. It is recommended to use external electrodes of gold in order to eliminate oxidation of the electrodes.

Soldering

Soldering electrical wires to the screen-printed silver electrode makes an excellent and time-stable connection. In order to avoid challenges with wetting the solder on the silver surface, always clean the external electrodes with a glass brush or steel wool.

The actuators may only be stressed axially. Tilting and shearing forces must be avoided.

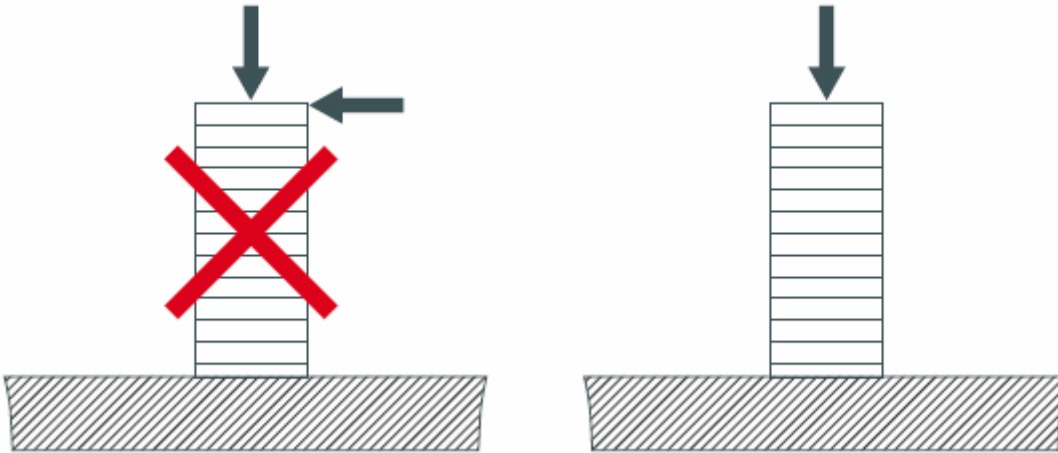

The actuators without preload are sensitive to pulling forces. It is recommended to apply a pre-load in order to optimize the performances of the actuators.

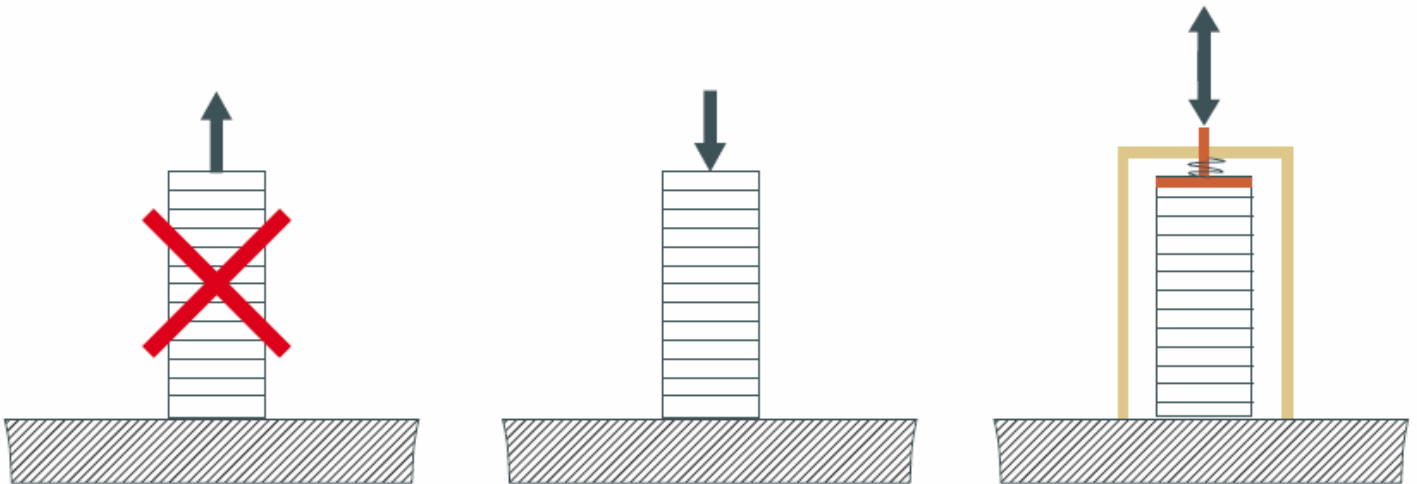

For linear actuators it is recommended not to use a metal plate on top and bottom in order to avoid short circuit.

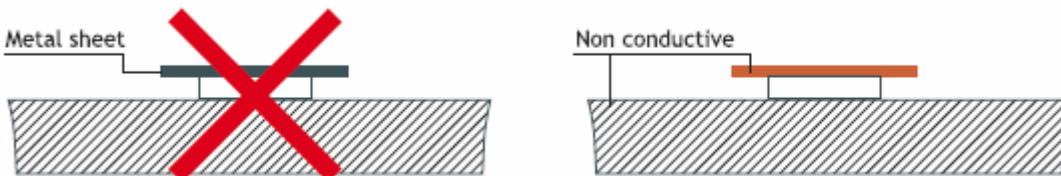

The force must be applied on the full surface of the actuator in order to assure a good load distribution.

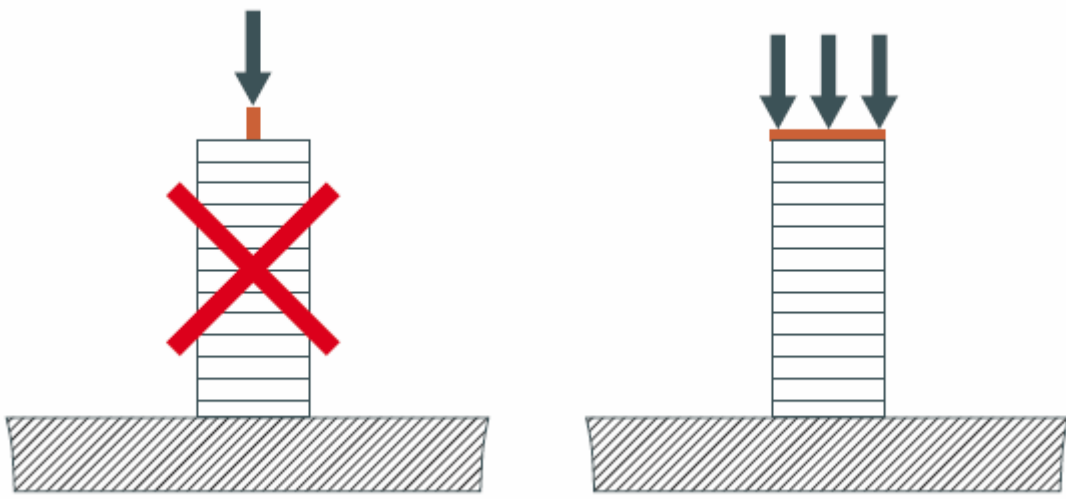

Epoxy glues are well suited for gluing piezoceramics.

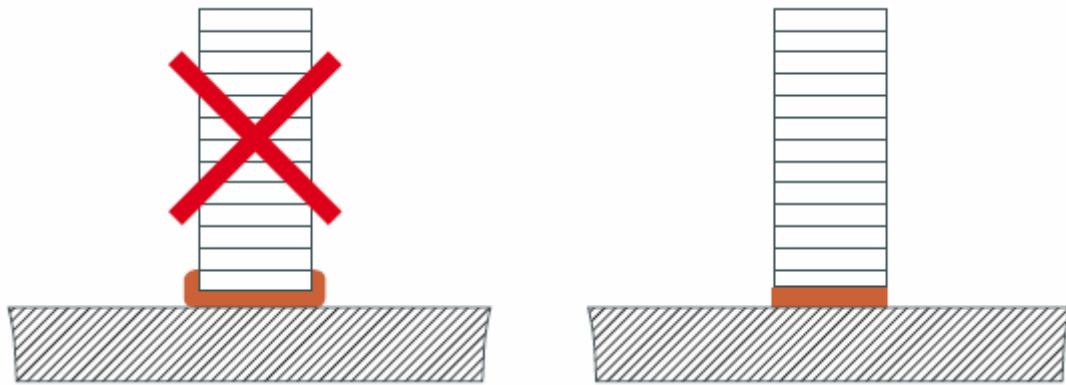

WIRES

When you order actuators from Noliac, you can have wires fitted to save time and money. However, you should consider these parameters, when you select a wire for connection:

- Operation voltage
- Intensity of current
- Operating temperature
- Environment for example vacuum

We recommend Teflon wires

Teflon wires can stand temperatures above 200 °C, whereas PVC wires only resist temperatures up to 80 °C. In tough operating conditions or in vacuum, it is recommended always to use Teflon isolated wire to guarantee the proper performance of PZT-elements.

Wire thickness (AWG)

The wire thickness (AWG) is determined by the current that has to be transmitted to and from the PZT-element. The required current is determined by the capacitance of the PZT-element, the maximum driving frequency and the maximum voltage U_{p-p} .

	Option A01	Option A02	Option C
Type	28 AWG Teflon	28 AWG Teflon	Custom
Length	200 +/- 10mm	200 +/- 10mm	To be defined
Position	Middle of the actuator	Middle of the actuator	To be defined
Direction	Perpendicular to the height	Toward top	To be defined

Type A01

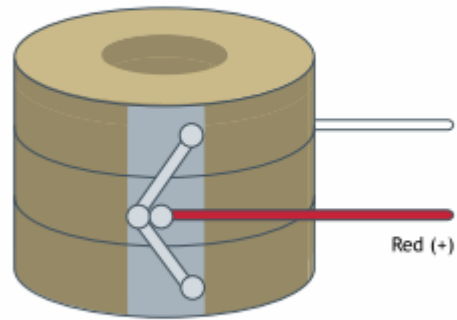
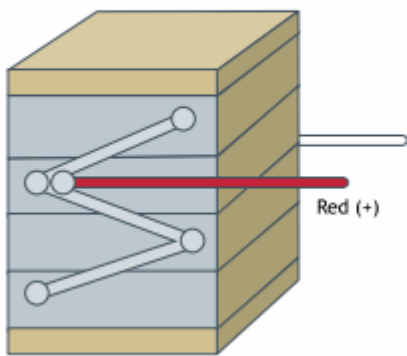

Type A02

