

PDUS210 - 210 Watt Ultrasonic Driver Manual and Specifications

Hardware Version 5

Revision History

Date	Revision	By	Changes
16/12/22	2	KB	Public document created
	3	KB	Updated unipolar section, fixed broken cross-references
28/04/23	4		Frequency modulation, Calibration, Multi PDUS210 Support

Contents

1	Introduction.....	3
2	Safety Warnings.....	3
3	Delivery Contents	3
4	Quick Start Recommendations	4
5	Electrical Specifications	4
6	Standard Output Voltage Ranges	4
7	Unipolar Output Voltage	6
8	Mechanical Specifications	7
9	PDUS210-FLEX Specifications	7
10	Introduction to Ultrasonic Transducers	8
11	PDUS210 Operation	9
12	Control of Vibration Amplitude	11
13	Choosing the Voltage Range	13
14	Front Panel.....	14
15	Rear Panel.....	16
16	Overload Protection.....	16
18	Desktop Software	17
19	Rack Mounting.....	30
20	Warranty.....	31

1 Introduction

The PDUS210 is a complete solution for driving and analysing ultrasonic actuators up to 210 Watts. Functions include high-speed resonance tracking of both series and parallel resonance modes, vibration amplitude control, pulsed excitation, frequency modulation, and analysis functions such as impedance and frequency response measurement. The PDUS210 is well suited to both OEM product integration and laboratory use for research and development. Applications include ultrasonic drilling and cutting, cleaning, medical devices, dental devices, ultrasonic testing, cavitation, and vaporization.

The PDUS210 can be controlled from multiple sources including a PC and the included software package, front panel controls, and/or external logic signals from a foot switch for example. An API for external controllers is also available for RS485 and USB connections, which are suitable for automatic test applications and embedded industrial machinery.

The PDUS210 generates a pure sine-wave output which is ideal for operating at the electrical parallel resonance, or 'anti-resonance'. This operating point is close to the mechanical resonance frequency but is less sensitive to changes in load dissipation, which is useful in precision machining applications where constant vibration amplitude is desired. Current and power control are also available for regulating vibration amplitude at the series resonance mode.

The PDUS210 is available with standard output voltage ranges from 17 Vrms to 282 Vrms, and current ranges from 0.7 Arms to 11 Arms. These ranges are optimized for load impedances ranging from 1.5 Ohms to 400 Ohms at resonance. For research and development applications, a reconfigurable version is available (PDUS210-FLEX), this version uses external output matching transformers to allow operation at any of the available output voltage ranges.

2 Safety Warnings

This product produces potentially lethal voltages up to 282 Vrms.

Observe Low-Voltage safety precautions (as per ANSI C84.1-1989), e.g.

- Use an observer trained in low-voltage rescue
- Do not operate with exposed conductors
- Use appropriate signage

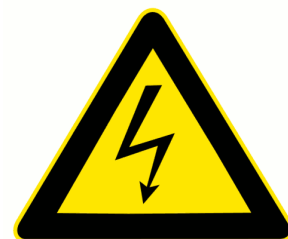

3 Delivery Contents

- PDUS210 Amplifier (in chosen configuration)
- IEC Power cable suited to the destination shipping address
- USB Cable (Type A to Type B)
- 3-Way plug-in screw terminals for RS485 signals (Amphenol TJ0331530000G)
- 4-Way plug-in screw terminals for output signals (Amphenol TJ0431530000G)

4 Quick Start Recommendations

Most users should read this document in full. However, users with expert knowledge of ultrasonic transducers and operating modes, may go straight to Section 17 (Desktop Software).

5 Electrical Specifications

Specification	Value	Notes
Output Voltage	0 – 800 Vp-p	See standard voltage ranges
Output Current Max	0 – 32 Ap-p	See standard voltage ranges
Load Impedance	1 Ω – 5 k Ω	See standard voltage ranges
Output Waveform	Sine wave	
DC Output Voltage	Zero	DC bias voltage on request
Output Isolation	Isolated output	Grounded is also possible
Max Output Power	210 W	With optimal load impedance
Internal Power Dissipation	150 W	Maximum
Frequency Range	See table below	6kHz to 500kHz with modifications
Power Supply	100 Vac – 250 Vac	IEC Connector
Controller	Phase tracking	Resonance or anti-resonance
Interface	USB, RS485, Logic	Software APIs are available

6 Standard Output Voltage Ranges

The specifications for fixed output models are listed below.

Order Code	Voltage RMS	Voltage pk-pk	Amps RMS	Amps pk-pk	Optimal Load (Ω)	Load Range Ohms [1]	Frequency kHz
PDUS210-800	282	800	0.71	2	400	260 – 840	20 – 200
PDUS210-600	212	600	0.92	2.6	225	146 – 472	20 – 200
PDUS210-400	141	400	1.4	4	100	65 – 210	20 – 200
PDUS210-200	70	200	2.8	8	25	16 – 52	20 – 200
PDUS210-175	62	175	3.2	9.1	19.1	12 – 40	10 - 100
PDUS210-100	35	100	5.7	16	6.25	4 – 13	20 – 200
PDUS210-50	17	50	11.3	32	1.56	1 - 3	20 – 200

[1] The load impedance range is the range of impedances which guarantee more than 100W of power supplied to the load. Higher or lower impedances can be driven but with reduced power.

The relationship between maximum achievable power and the load impedance is plotted in the following figure. In this plot, the impedance is normalized by the optimal impedance; that is,

$$Z_{norm} = \frac{Z_{Load}}{Z_{opt}}$$

For example, the optimal impedance of the PDUS210-400 is 100 Ohms, so with a 50 Ohm load, the normalized impedance is 0.5, From the plot, it can be observed that greater than 100 W can be achieved with a normalized impedance from 0.65 to 2.1, which for the PDUS210-400, is 65 Ohms to 210 Ohms.

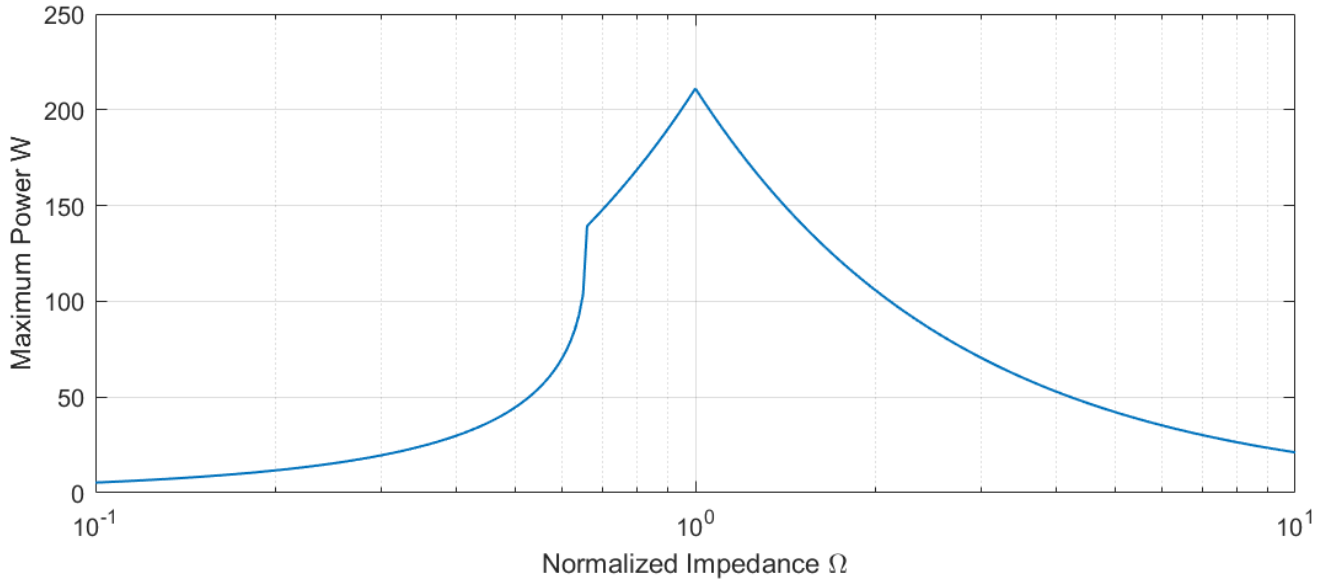

Figure 1. Maximum output power versus normalized impedance

The impedance ranges for other common power levels are listed in the following table. For example, all amplifiers will supply more than 150W with a normalized load impedance between 0.71 and 1.4. For the PDUS210-400, this is equivalent to 71 Ohms and 140 Ohms.

Minimum Power	Z_{Load} Lower Bound	Z_{Load} Upper Bound
150W	$0.71 \times Z_{opt}$	$1.4 \times Z_{opt}$
100W	$0.65 \times Z_{opt}$	$2.1 \times Z_{opt}$
50W	$0.53 \times Z_{opt}$	$4.2 \times Z_{opt}$

Table 1. Minimum achievable power versus load impedance.

7 Unipolar Output Voltage

The output voltage of a standard PDUS210 or TX210 device is bipolar. For example, the maximum output voltage of the PDUS210-200 or TX210-200 is +/-100V. The PDUS210 and TX210 can also be configured with a positive or negative unipolar output range using the order code suffix –UnipolarPositive or –UnipolarNegative. For example, the order code PDUS210-200-UnipolarPositive or TX210-200-UnipolarPositive would result in a maximum output voltage range of 0V to +200V, as shown in Figure 2.

The unipolar option adds a DC offset voltage which is equal to half the signal amplitude; therefore, the resulting voltage is always between zero volts and the chosen amplitude, as shown in Figure 2. Compared to a fixed DC offset voltage, this approach minimizes the average DC voltage, which improves transducer lifetime.

Since the output of the standard PDUS210 and TX210 is electrically isolated, the polarity of the offset voltage can be inverted by reversing the connection of the transducer to the amplifier or transformer. In other words, except for very specific applications where the phase of the output voltage is important, the –UnipolarPositive option can be used to create both positive and negative offset voltages by reversing the polarity of the transducer connection.

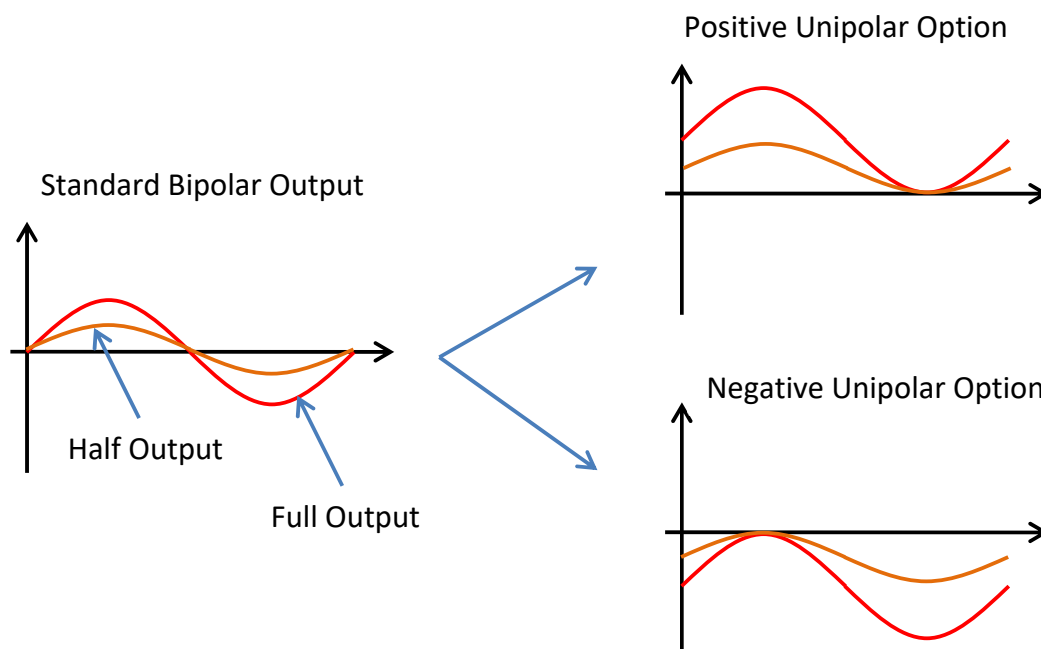

Figure 2 Comparison of standard bipolar output voltage and unipolar output options.

Notes:

- The amplifier signal acquisition is AC coupled, so DC offsets cannot be viewed in the desktop software. DC offsets will need to be confirmed with a multimeter or oscilloscope.
- The unipolar circuit reduces the output voltage by up to 3% at full power and 20kHz frequency. This voltage drop is proportional to output current and inversely proportional to frequency, in most cases the reduction of the output voltage will be less than 1%.

8 Mechanical Specifications

The mechanical specifications of the enclosure are listed below.

Specification	Value	Notes
Dimensions [1]	212 x 304.8 x 88 mm (8.35 x 12 x 3.46 in)	L x W x H
Mass	2 kg (4.4 lb)	
Temperature	0C – 50 C (32 - 122 F)	
Humidity	Non-condensing	
Ingress Protection	No dust or water ingress protection [2]	

[1] A 3D Model is available at www.piezodrive.com

[2] The PDUS210 requires clean room air for cooling.

9 PDUS210-FLEX Specifications

The PDUS210-FLEX is identical to the standard PDUS210 except that it requires an external transformer connected between the amplifier and transducer using the supplied cable. This allows the user to switch between different output voltage ranges by changing the external transformer. For operating instructions, please refer to PDUS210-FLEX Operation.

The PDUS210-FLEX must be purchased with at least one external transformer. The default output configuration is electrically isolated with a bipolar voltage. Refer to Unipolar Output Voltage for other options. The available part numbers and specifications are:

Order Code	Turns Ratio	Voltage RMS	Voltage pk-pk	Amps RMS	Amps pk-pk	Optimal Load	Load Range Ohms [1]	Frequency kHz
PDUS210-800	18.18	282	800	0.71	2	400	260 – 840	20 – 200
PDUS210-600	13.64	212	600	0.92	2.6	225	146 – 472	20 – 200
PDUS210-400	9.09	141	400	1.4	4	100	65 – 210	20 – 200
PDUS210-200	4.55	70	200	2.8	8	25	16 – 52	20 – 200
PDUS210-175	3.98	62	175	3.2	9.1	19.1	12 – 40	10 - 100
PDUS210-100	2.27	35	100	5.7	16	6.25	4 – 13	20 – 200
PDUS210-50	1.14	17	50	11.3	32	1.56	1 - 3	20 – 200

Table 2. External transformer specifications (only for the PDUS210-Flex)

A kit containing five transformers is available (TX210-Kit1), which consists of the following voltage ranges: 35 Vrms, 70 Vrms, 141 Vrms, 212 Vrms, and 282 Vrms.



Figure 3. Output transformer (e.g. TX210-800)

Specification	Value	Notes
Input Connector	Plug-in screw terminal	Cable supplied with PDUS210-FLEX
Output Connectors	Identical to PDUS210	See Front Panel
Transformer Dimensions	104 x 57 x 51 mm	L x W x H
Mass	0.2 kg	

Table 3. External transformer mechanical specifications

10 Introduction to Ultrasonic Transducers

An introduction to the behaviour and operation of ultrasonic transducers can be viewed at

- <https://www.piezodrive.com/ultrasonic-drivers/intro-ultrasonic/>

Please familiarize yourself with these concepts before operating the PDUS210.

The most important concept to understand is the relationship between the electrical and mechanical impedance response of a transducer. Figure 4 plots the mechanical and electrical frequency response of an ultrasonic transducer.

The impedance minima at f_s is known as the series resonance, which is approximately equal to the mechanical resonance frequency. At this frequency, the impedance phase response has a high positive slope and a value of approximately zero degrees. In this mode, the current is approximately proportional to the vibration amplitude, so current control is used to maintain constant vibration amplitude. If the mechanical load does not vary significantly, constant voltage amplitude is also appropriate.

The impedance maxima at f_p is known as the parallel resonance, which also has an electrical phase of approximately zero degrees but a high negative slope. In this mode, the voltage is approximately proportional to the vibration amplitude, so constant voltage results in approximately constant vibration amplitude regardless of mechanical load variations.

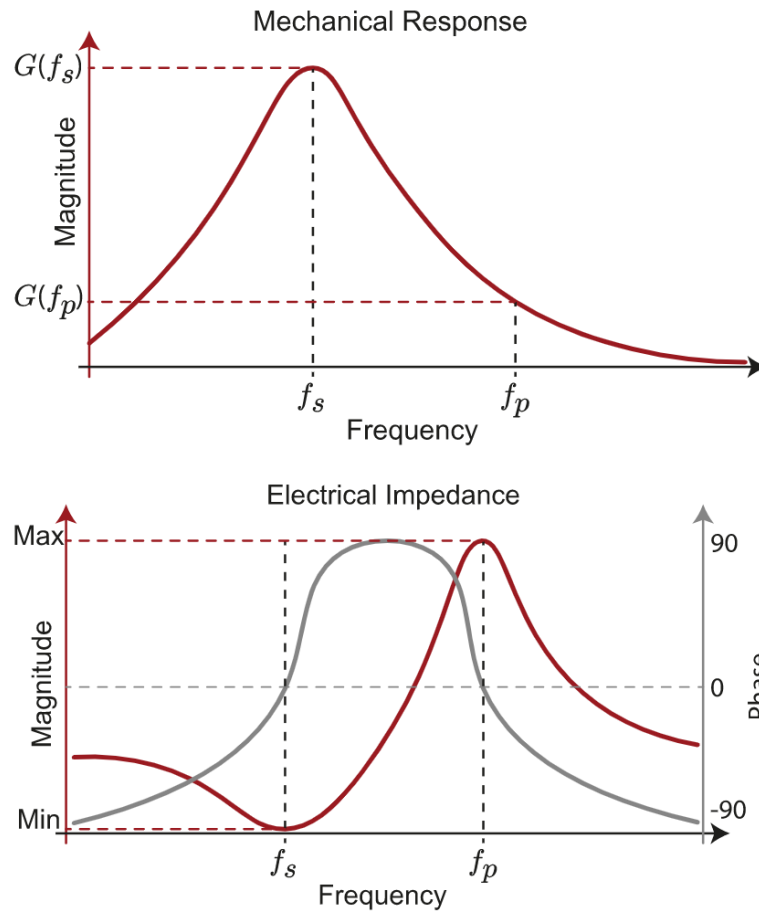

Figure 4. Electrical and mechanical frequency response of an ultrasonic transducer

11 PDUS210 Operation

11.1 Overview

The operating principle of the PDUS210 is summarized in Figure 5. The transducer on the right is connected to the output transformer. The transformer converts the internal +/-24V drive voltage to the desired output voltage range, for example +/-200V. By default, the output connection to the transducer is electrically isolated from ground but the negative output can also be internally grounded using the jumper shown.

During operation, the voltage and current in the transducer is used to estimate the phase θ . The measured phase is then used to control the frequency of the signal generator by comparing it to the phase set point θ_{ref} . The frequency controller stabilizes the feedback loop and controls the settling time of the closed loop system. The feedback gain is normally determined experimentally by slowly increasing the gain until the desired performance is reached or the response begins to become unstable.

The signal generator has a variable amplitude, and the frequency is normally controlled by the phase control loop. It is connected to the power amplifier, which drives the output transformer and transducer.

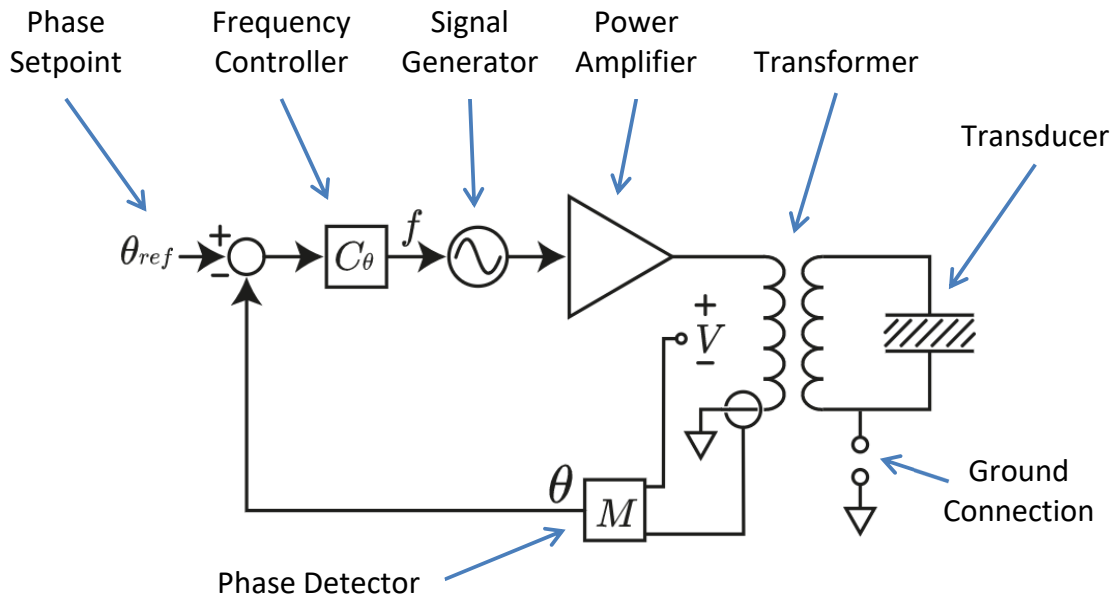

Figure 5. PDUS210 operation (in constant voltage, resonance tracking mode).

11.2 Resonance Tracking

The resonance tracking system of the PDUS210 is illustrated Figure 5. The phase detector measures the impedance phase angle between the primary voltage and current. The frequency controller $C_{\theta}(s)$ varies the drive frequency to maintain a constant phase set point θ_{ref} , which is usually equal to zero.

To operate at a series resonance (impedance minima), the phase controller gain must be positive to create a stable operating point.

To operate at a parallel resonance (impedance maxima), the phase controller gain must be negative to create a stable operating point.

Applications with high losses, i.e. low quality factor, may have a non-zero impedance phase angle at resonance, e.g. 45 degrees. In such cases, an impedance response should be performed first, to identify the desired operating phase that corresponds to the desired mechanical resonance.

12 Control of Vibration Amplitude

Power ultrasonic applications can be categorized as either constant mechanical load, or variable mechanical load. The requirements for both cases are described in the following.

12.1 Constant Mechanical Load

Constant load applications are the simplest case and include, for example, ultrasonic cleaners, ultrasonic mixers, and any other application where the mechanical load does not vary significantly. These applications can be operated with constant voltage at either the series or parallel resonance.

12.2 Variable Mechanical Load

Applications with variable mechanical load include ultrasonic drills and cutters where the mechanical load conditions vary during operation. These applications generally require some form of amplitude control to maintain vibration amplitude when the mechanical load dissipation increases; and to avoid vibration amplitude increasing when the mechanical load dissipation is reduced.

To achieve approximately constant vibration amplitude, a transducer can be driven with constant voltage at the parallel resonance frequency, or constant current at the series resonance frequency.

Constant voltage is the natural operating mode of the PDUS210 but constant current can also be achieved by enabling the current tracking mode. The operation of current tracking mode is illustrated in Figure 6. Current tracking mode has the same frequency control loop as Figure 5 but also has an additional feedback loop that varies the voltage to maintain a constant load current. The current set point is I_{ref} and the controller is C_I .

Current tracking mode is most useful for achieving constant vibration amplitude in transducers operated at the series resonance mode (impedance minima).

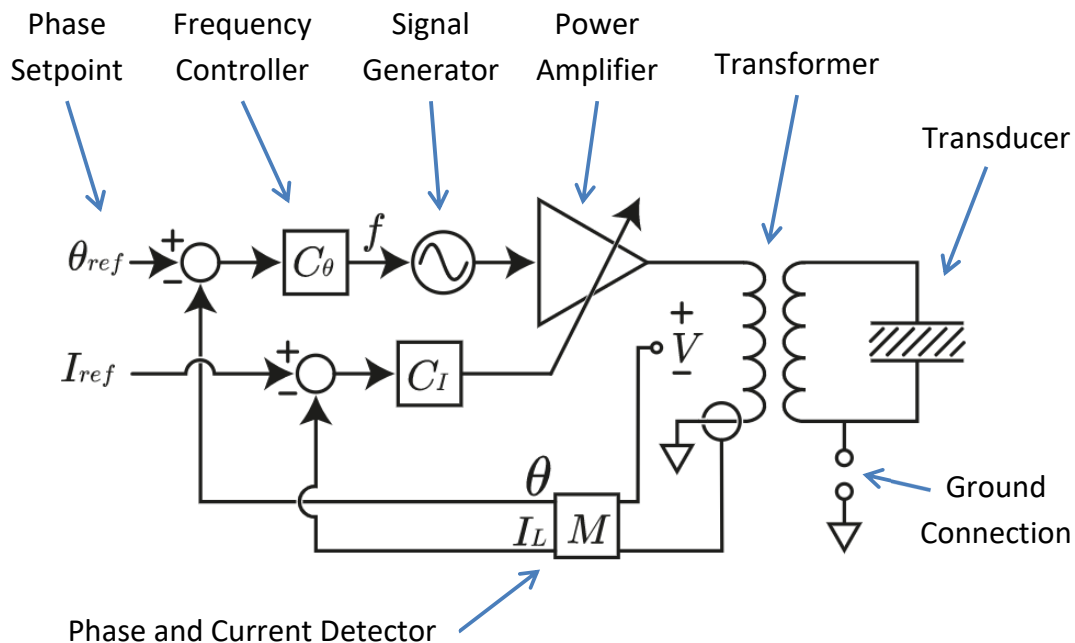

Figure 6. Phase and current control loop in the PDUS210 driver.

12.3 Power Control

When operating with constant voltage or current, a limit can be set on the maximum power dissipation in the load. This power is the sum of dissipation in the mechanical load and the transducer itself.

In some applications, such as welding and cleaning, it may be preferable to control the dissipated power rather than the vibration amplitude. The PDUS210 has a power control function that varies the voltage to maintain a constant power dissipation in the load. As shown in the Figure 7, the power control loop includes the power measurement P which is compared to the power set-point P_{ref} . The gain of the controller P_{ref} is tuned experimentally to provide a fast transient response and stability.

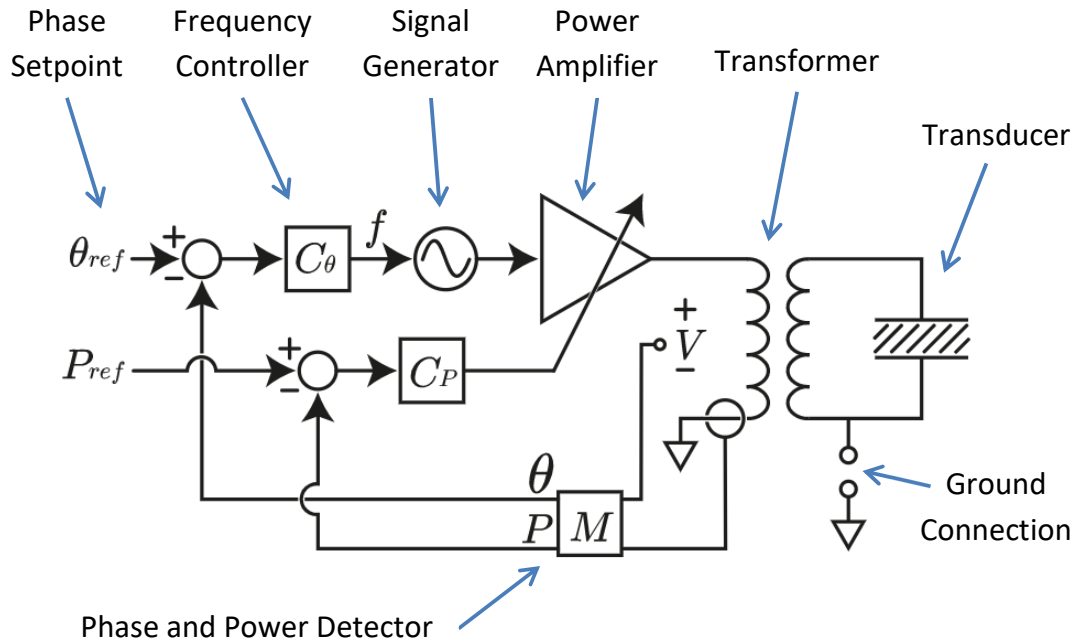

Figure 7. Phase and power control loop in the PDUS210 driver.

13 Choosing the Voltage Range

The PDUS210 is available in voltage ranges from 17 Vrms to 282 Vrms, which suit load impedances ranging from 1.5 Ω to greater than 400 Ω. The optimal choice is determined by the transducer impedance at resonance, and the choice of series or parallel resonance. If the load impedance is unknown, or a range of load impedances are expected, the PDUS210-Flex configuration is recommended with the transformer kit (TX210-Kit1), please refer to PDUS210-FLEX Specifications.

To determine the ideal voltage range, start by measuring the impedance of the transducer at the series and parallel resonance. This can be performed with an impedance analyser or simply a signal generator and oscilloscope. If possible, these tests should be performed at moderate power with both minimum and maximum load conditions. A PDUS210 driver is ideal for performing this measurement. Fill out the values in the table below:

	Unloaded	Fully Loaded
Series Resonance	$R_{1,min}$:	$R_{1,max}$:
Parallel Resonance	$R_{2,max}$:	$R_{2,min}$:

Table 4. Operating impedance at resonance

13.1 Series Resonance

For operation at the series resonance, the most suitable amplifier has an optimal impedance which is close to, or slightly greater than the fully loaded impedance. Since transducer impedance tends to increase with applied power, an amplifier with a higher optimal impedance is recommended. If the amplifier has a higher optimal impedance than the load, the current limit will be reached before the voltage limit, and the maximum achievable output power is:

$$P = I_{rms}^2 R_{1,max}$$

where I_{rms} is the maximum driver current.

13.2 Parallel Resonance

For operation at the parallel resonance, the most suitable amplifier has an optimal impedance which is close to, or slightly less than the fully loaded impedance. Since transducer impedance tends to reduce with applied power, an amplifier with a lower optimal impedance is recommended. If the amplifier has a lower optimal impedance than the load, the voltage limit will be reached before the current limit, and the maximum achievable output power is:

$$P = \frac{V_{rms}^2}{R_{2,min}}$$

where V_{rms} is the maximum driver voltage.

13.3 Custom Voltage Range

Custom voltage ranges and impedance-matching network design is available on request.

14 Front Panel

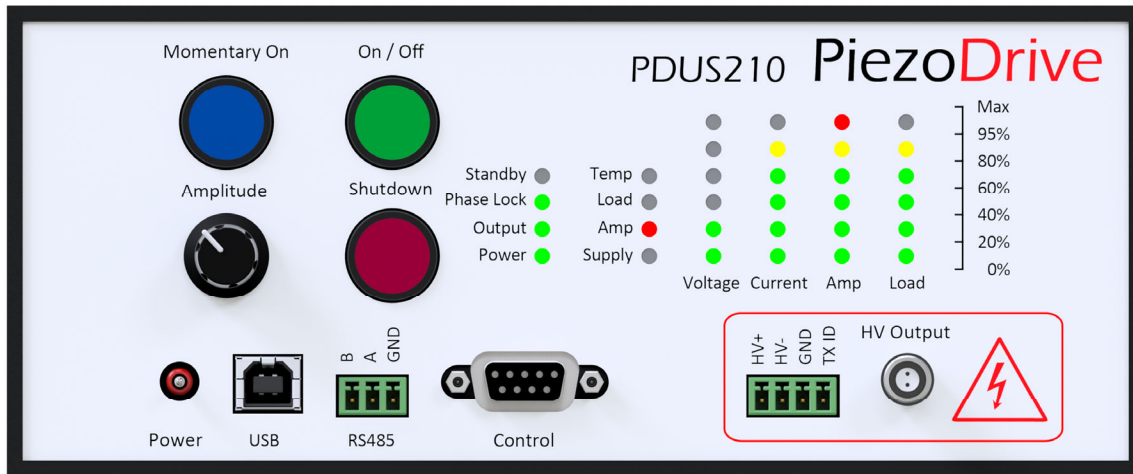

Indicator	Description
Standby	Indicates that the output is enabled but not active
Phase Lock	The measured phase is within +/-10 degrees of the phase setpoint
Output	Output is enabled
Power	Power is on
Temp	A thermal overload has occurred, enable the amplifier to restart
Load	Load power has exceeded the limit, enable the amplifier to restart
Amp	Amplifier dissipation has exceeded 150W, enable the amplifier to restart
Supply	Supply current limit has been exceeded, enable the amplifier to restart
Voltage Range	Output voltage, relative to maximum voltage limit
Current Range	Output current, relative to maximum current limit
Amp Range	Amplifier power dissipation, relative to 150W
Load Range	Load power dissipation, relative to maximum power limit

Front panel button functionality will be changed by the front panel mode set in the **settings tab** of the desktop software.

Control	Function
Momentary On	Tracking: Output is active while pressed Pulse: Starts the pulse output, if pulse is not “Continuous” output will go to standby once “Number of Pulses” is reached. Frequency Modulation: Starts the frequency modulation output. Disabled: Nothing
Amplitude	Amplitude control, “Use Remote Amplitude” must be enabled in software
On / Off	Tracking: Output is active while pressed

Pulse: Pulse output is active, “Continuous” is ignored.

Frequency Modulation: Frequency modulation output is active.

Disabled: Nothing

Shutdown	Tracking/Pulse/Frequency Modulation: Output is disabled, and device is unlocked. Disabled: Nothing
----------	---

Power	Turns the power on
-------	--------------------

Connector	Description
USB	Connection to PC, requires a Type A to Type B cable (included)
RS485	RS485 interface, suits Amphenol TJ0331530000G connector
Control	External logic control, see notes [1]
Screw HV Output	Suits Amphenol TJ0431530000G connector, see notes [2]
LEMO HV Output	Suits LEMO 0B.302 Connector (e.g. FGG.0B.302.CLAD42)

[1] The amplifier can be controlled by external logic signals, such as foot switches etc. The signal connector is a 9-way DSUB receptacle, which suits any 9-way male DSUB plug. The signals and pin layout are shown in Figure 8 and Table 5.

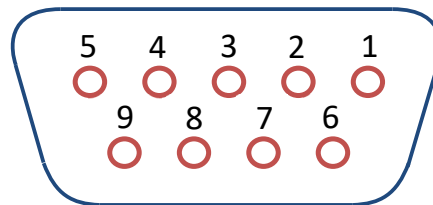

Figure 8. Front view of control signals connector

Signal	Pin	Function
3.3V Power	1	3.3V Power from the amplifier. 20mA maximum current. Unprotected.
Amplitude	2	Remote amplitude control. 0V to 2.9V maps to 0 to 100%. Zin = 500 Ω.
Momentary	3	Identical to pressing the momentary button. 3.3V logic.
Status 0	4	For future assignment, will be used to indicate amplifier status. 3.3V logic.
Shutdown	5	Identical to pressing the shutdown button. 3.3V logic.
Ground	6	Ground, also connected to the connector shield. Connected to IEC earth.
Status 1	7	For future assignment, will be used to indicate amplifier status. 3.3V logic.
Connected	8	Connect this to pin 1, used to indicate the presence of an external controller
On-Off	9	Identical to pressing the on/off button. 3.3V logic.

Table 5. Control signals pinout

[2] The transducer is connected between HV+ and HV-, which are electrically isolated from ground. The transducer can be grounded remotely, or by connecting either HV+ or HV- to the Ground pin. The

TX ID pin is reserved for future use, this is a low-voltage pin aimed at communicating calibration information with external transformers.

15 Rear Panel

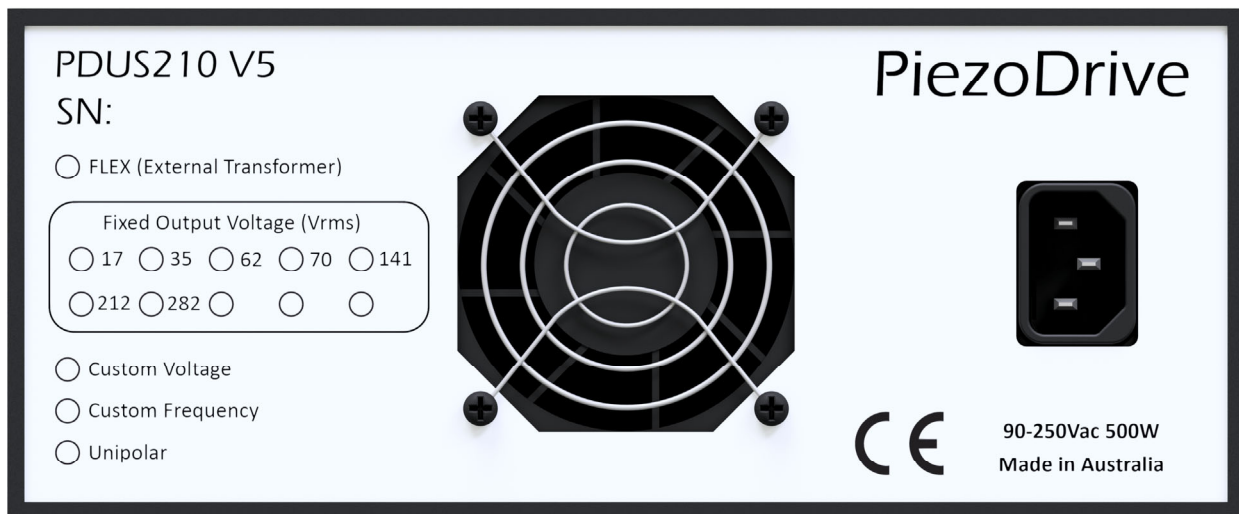

The rear panel consists of an IEC C14 mains power inlet (100 Vrms to 250 Vrms) and an air inlet.

16 Overload Protection

16.1 Temperature Overload

- Triggered when the heatsink temperature exceeds 60C.
- The output will be disabled, and the Temp indicator will light.
- An enable command is required to clear the overload.
- Check the fan and heatsink for blockages.

16.2 Load Power Dissipation Overload

- Triggered when the load power dissipation exceeds the defined limit.
- The output will be disabled, and the Load indicator will light.
- An enable command is required to clear the overload.
- Increase the Load power limit, or reduce the output amplitude.

16.3 Amplifier Power Dissipation Overload

- Triggered when the amplifier power dissipation exceeds 150 W.
- The output will be disabled, and the Amp indicator will light.
- An enable command is required to clear the overload.
- Reduce the output amplitude and check the transducer impedance.

16.4 Supply Hardware Overload

- Triggered when the internal power supply is overloaded.
- The output will be disabled, and the Supply indicator will light.
- An enable command is required to clear the overload.
- Reduce the output amplitude and check the transducer impedance.

17 Desktop Software

17.1 Installation

Download the latest software from www.piezodrive.com and run the executable, which will extract the desktop software to the selected folder. Go into the folder and launch the executable (piezodrive.exe). Ignore operating system warnings about security, this software does not have a windows security certificate. However, this will be added in future releases.

17.2 Firmware Update

The desktop software will automatically download the latest compatible version of the firmware; thus, it is import to check for new desktop software periodically at:

<https://www.piezodrive.com/ultrasonic-drivers/pdus210-ultrasonic-driver/>

17.3 Offline Firmware Update

Manually [download](#) the latest firmware. Also download the latest version of the desktop software.

The procedure for a manual firmware update is:

1. Turn the amplifier power on while holding the red shutdown button. This places the amplifier in update mode and the front panel indicators will display a flashing pattern.
2. Open the desktop software and ensure the amplifier is connected by a USB cable.
3. Open the settings page and click the Load button at the bottom of the settings page. Use the file browser to select the downloaded firmware.
4. Click the 'Update Firmware' switch to install the firmware on the amplifier. Do not interrupt this process or the amplifier will become unusable. If the amplifier was not already in update mode, the software will ask you to restart the amplifier while pressing the shutdown button.

17.4 Overview of User Interface Controls

Enable Switch - Enables and disables the amplifier output.

- Enabling the amplifier clears all previous overload conditions.

Phase Tracking Switch - Enables and disables phase tracking.

- When enabled, the output frequency will be adjusted until the measured phase equals the phase set point.
- When enabled, the output frequency cannot be manually changed.
- When the maximum frequency is encountered, the frequency will jump to the minimum, and vice-versa.

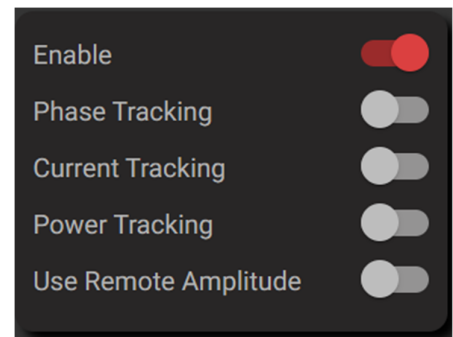

Current Tracking Switch - Enables and disables current tracking.

- The output voltage will be adjusted until the measured current equals the current setpoint.
- When enabled, the output voltage cannot be manually changed.
- Recommended when tracking a series resonance.
- Will disable power tracking
- The voltage will not be adjusted until the phase tracking is locked, i.e. there is less than 10 degrees difference between the measured phase and the phase set point.

Power Tracking Switch - Enables and disables power tracking.

- The output voltage will be adjusted until the measured load power equals the power set point.
- When enabled, the output voltage cannot be manually changed.
- Will disable current tracking
- The voltage will not be adjusted until the phase tracking is locked, i.e. there is less than 10 degrees difference between the measured phase and the phase set point.

Remote Amplitude Switch - Enables and disables the front panel amplitude control.

- When enabled, the remote dial will change the output voltage from zero to the maximum amplitude.
- If current tracking is enabled, the dial will change the current set point from zero to the maximum output current.

- If power tracking is enabled, the dial will change the power set point from zero to the maximum load power.

Max Power - The maximum power that can be supplied to the load, in Watts.

- If this maximum value is exceeded, an overload will be triggered and the amplifier output will be disabled.

Max Voltage - The output voltage limit, in Volts RMS.

- Limits voltage when power or current tracking is enabled

Max Current - The maximum current that can be supplied to the load, in Amps RMS.

- Limits current when power or current tracking is enabled

Transformer Turns - The transformer turns for the FLEX version.

Voltage - Sets the output voltage, in Volts RMS.

- Cannot be changed if power or current tracking is enabled

Frequency (Hz) - The output frequency, in Hertz.

- Cannot be changed if phase tracking is enabled.
- Limited to values between the minimum and maximum frequencies.

Minimum (Hz) - The minimum output frequency, in Hertz.

- Limited to values between 5000 Hz and the maximum frequency.
- The operating frequency range should not exceed the output transformer specifications.

Maximum (Hz) - The maximum output frequency, in Hertz.

- Limited to values between the minimum frequency and 340 kHz.
- The operating frequency range should not exceed the output transformer specifications.

Phase Setpoint - The phase set point, in degrees.

- Phase Control Gain Shows and sets the control gain for phase tracking.
- Negative values are used to track a parallel resonance.
- Positive values are used to track a series resonance.

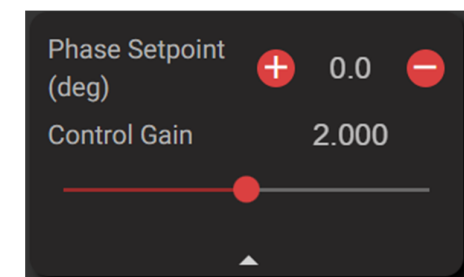
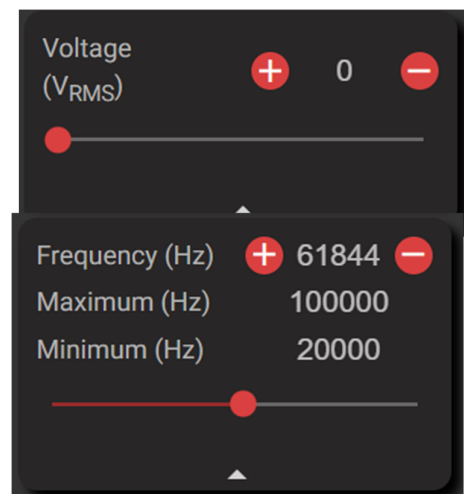
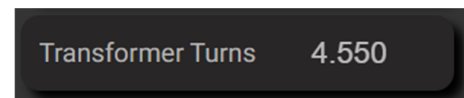
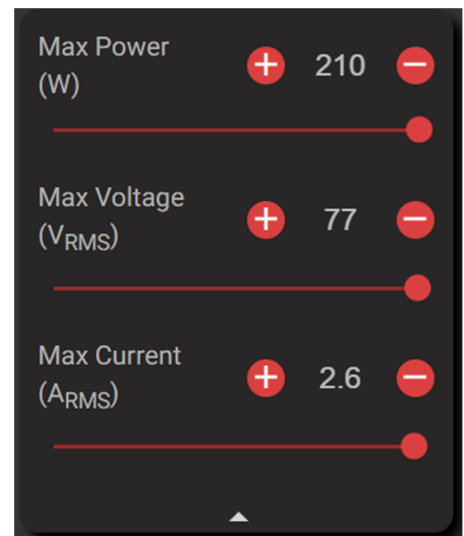

- Increasing the absolute value will increase the controller speed but may lead to instability.

Current Setpoint - The current set point, in Amps RMS.

Current Control Gain - The controller gain for the current tracking controller.

- Accepts only positive values.
- Increasing the value will increase the controller speed but may lead to instability.

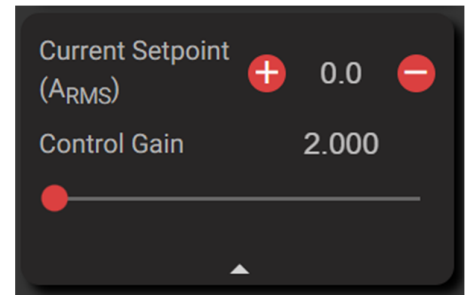

Power Setpoint - The power set point, in Watts.

Power Control Gain - The control gain for power tracking.

- Accepts only positive values.
- Increasing the value will increase the controller speed but may lead to instability.

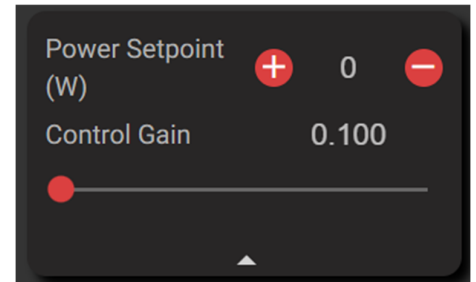

Save On Device - Saves all current settings to the amplifier non-volatile memory.



17.5 Load Voltage and Current Plots

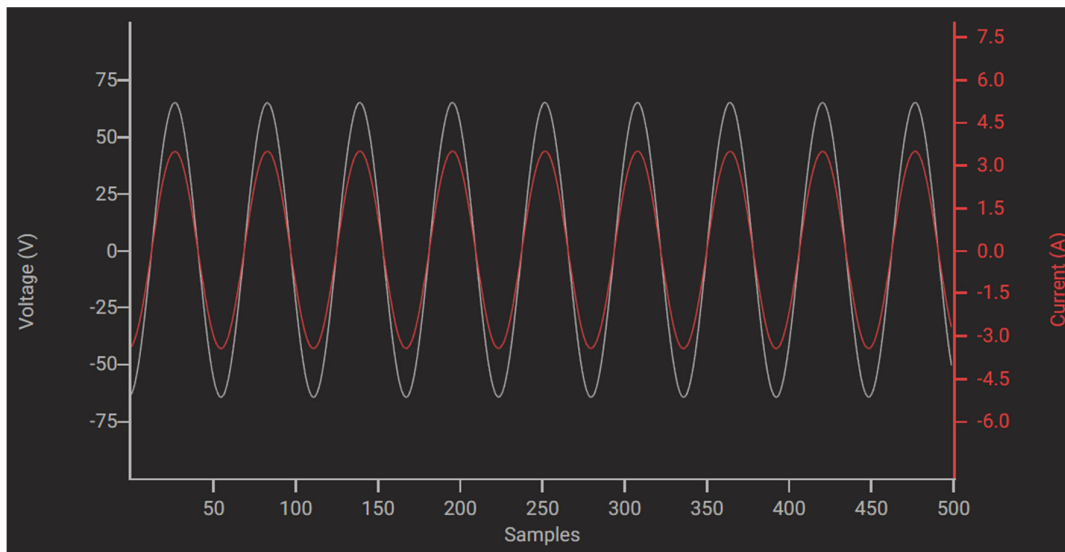

Current (A) – Load current, measured at 3.4 MSPS, 500 samples are displayed.

Voltage (V) – Load voltage, measured at 3.4 MSPS, 500 samples are displayed.

To scale an axis, hover over the axis and use the mouse wheel

- Scale both the current and voltage waveforms by hovering over the plotted signals

To auto-scale an axis, double click the axis.

- Auto-scale both the current and voltage by doubling clicking in the plot window.

17.6 Frequency and Phase Graph

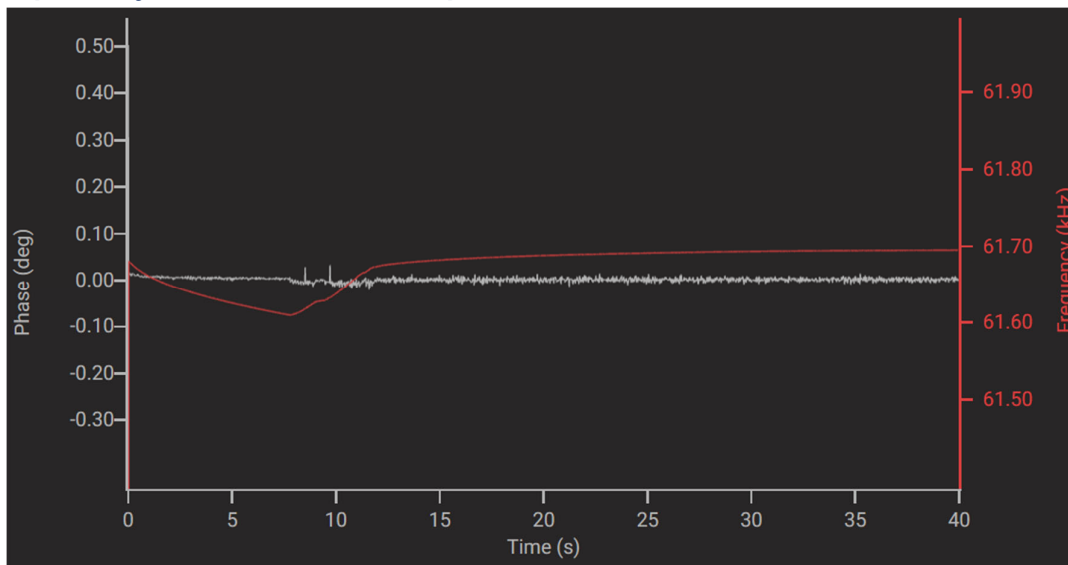

Phase (deg) – Phase of the load impedance (in degrees), measured at 50 SPS for 40 seconds

Frequency (kHz) – Operating frequency (in kHz), measured at 50 SPS for 40 seconds

- To scale an axis, hover over the axis and use the mouse wheel
- To auto-scale an axis, double click the axis.
- The phase and frequency axis can be panned by left-click and dragging

17.7 Small Graphs

Time histories of the amplifier power, load power, temperature, impedance, and RMS current will appear when the software is maximized. Most of these have a fixed scale.

17.8 Overview of Bottom Bar

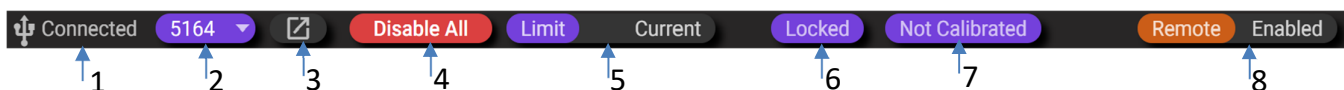

1 USB Status – Displays the connection status of the USB connection.

2 Device Selector – Drop down that lets user select via serial number which PDUS210 to control, if multiple PDUS210s are connected to the computer.

3 Pop Out Device – Pops out a new window for the currently selected PDUS210.

4 Disable All – Disables all connected PDUS210s.

5 Limit/Overload Status – Displays the current limit or overload status, overloads will have preference.

6 Software Locked Status – Displays if the desktop software control has been locked out by the front panel or remote, can only be unlocked by pressing “Shutdown” button on the front panel or remote.

7 Not Calibrated Warning– Displays if the currently selected PDUS210 is not calibrated.

8 Remote/Front Panel Status – Displays the status of remote/front panel control.

18 Frequency Sweep Mode

Click the sweep tab to enter the frequency response analysis mode.

Set Button – Sets the sweep controls to the following recommended settings:

- 50% of maximum output voltage.
- 10% of maximum output current.
- Frequency step = 100 Hz
- Settling time = 10 ms
- Averages = 10 (per frequency)

The above settings are a reasonable trade-off between measurement speed and measurement resolution.

Transducers with a high Q-factor ($Q > 100$) may need the following adjustments:

- Frequency step = 10 Hz (or less)
- Settling time = 100 ms (or longer)

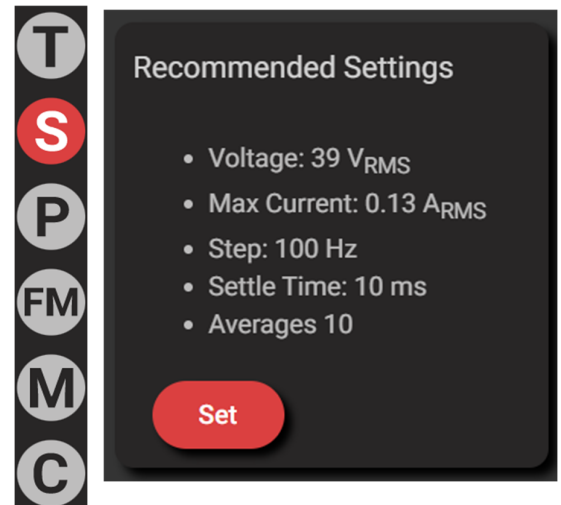

For typical transducers, the frequency sweep will proceed with active current regulation, i.e. the voltage will be varied proportional to the load impedance, the approach provides maximum dynamic range.

Max Current - The maximum load current, in Amps RMS.

- Limits current when power or current tracking is enabled.

Voltage - The nominal output voltage, in Volts RMS.

Start - Start frequency, in Hertz

End - End frequency, in Hertz

Step - The frequency step or the resolution of the sweep.

Settle Time – The time delay in milliseconds between frequencies

Averages – The number of averages for each frequency measurement.

Sweep Settings

Voltage (Vrms)	38.7
Max Current (Arms)	0.13
Start (Hz)	20000
End (Hz)	100000
Step (Hz)	100
Settle Time (ms)	10
Averages	10

Max Power (W) – 210.0 +

Start

18.1 Frequency Sweep Plot

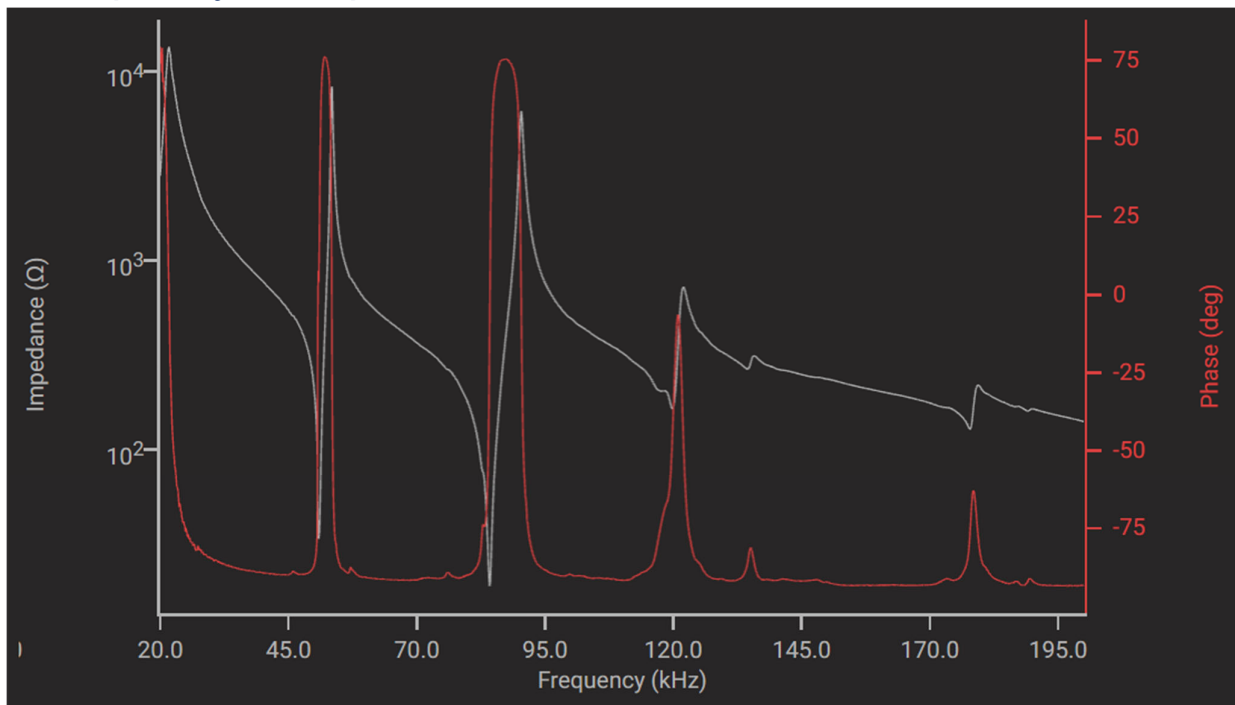

Impedance – The measured impedance in Ohms, log scale.

Phase- The measured phase in degrees.

To scale an axis, hover over the axis and use the mouse wheel

- Scale the plot by hovering over the plotted signals

To auto-scale an axis, double click the axis.

- Auto-scale both signals by double clicking in the plot window.

The impedance and phase axis can be panned by left-click and dragging

19 PDUS210-FLEX Operation

The PDUS210-FLEX is identical to the standard PDUS210 except that it requires an external transformer connected between the amplifier and transducer using the supplied cable. This allows the user to switch between different output voltage ranges by changing the external transformer.

The PDUS210-FLEX must be purchased with at least one external transformer. The available part numbers and specifications are listed in PDUS210-FLEX Specifications.



Figure 9. PDUS210-FLEX Output transformer (e.g. TX210-800)

To operate the PDUS210-FLEX, the instructions are identical to the standard PDUS210 except for the following steps that must be completed first, or when changing the transformer:

1. Disconnect the amplifier from power and connect the desired transformer, e.g. TX210-800
2. Connect the PDUS210-FLEX output to the transformer input, using the supplied cable
3. Read the turns-ratio (N) from the transformer, or specifications table, and enter this into the textbox in the desktop software labelled 'Turns Ratio'.
4. Check that the maximum and minimum frequency settings are appropriate for the transformer.
5. In the desktop software, press the 'Save on Device' button. This step is optional but will retain settings after cycling the power.

20 RS485 Interface

RS485 is a two-wire communication standard, commonly used for machine-to-machine, and computer-to-machine communications ([Introduction to RS485](#)).

The PDUS210 responds to the commands described in <https://github.com/PiezoDrive/RS485-API>

For testing purposes or to control the amplifier from a PC, an RS485 USB cable is required, for example, FTDI USB-RS485-WE-1800-BT. The connection diagram below is recommended. A text-based application such as [Putty](#) can be used to send or receive commands.

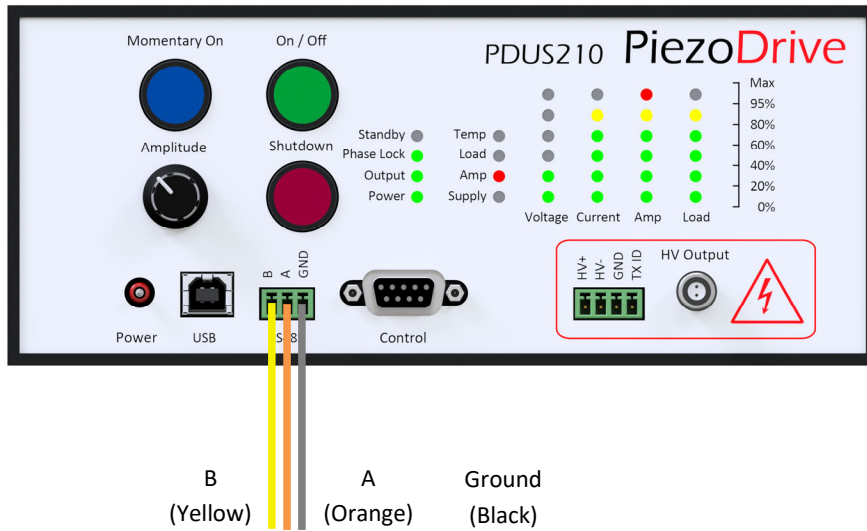

Baud Rates	9600, 115200, 460800, 921600
Data Bits	8
Stop Bits	1
Parity	None

Table 6. RS485 Parameters



Figure 10. USB-RS485-WE-1800-BT Cable

21 Pulse Mode

The pulsed mode creates a series of short bursts of defined duration and repetition rate (period). The number of applied pulses and amplitude rate-of-change (slew rate) can also be chosen. Phase, current and power tracking, used in pulsed-mode; however, measurements and control are only preformed once per pulse. Hence, for long pulse periods the controllers will be slow.

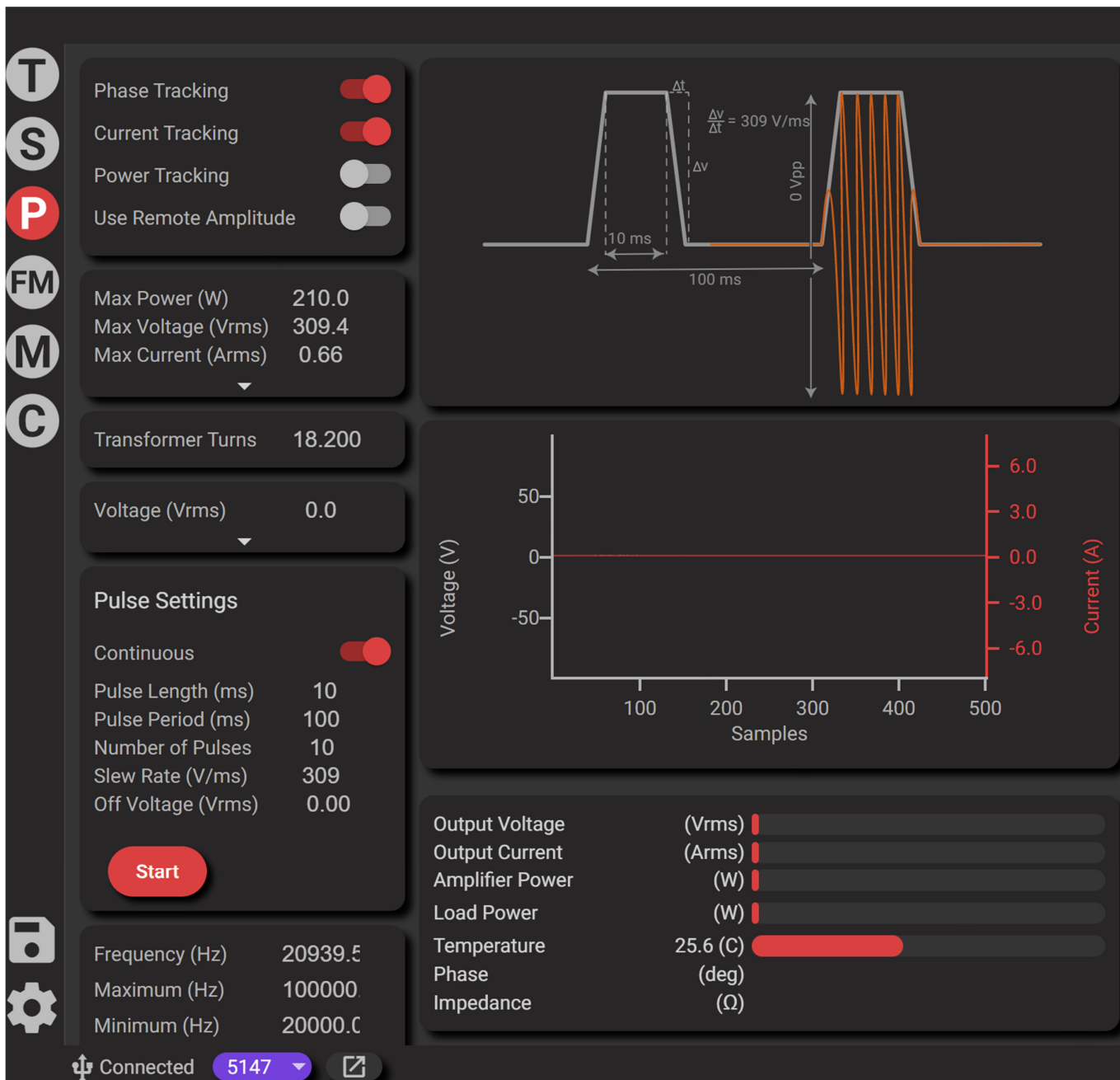

Continuous – If enabled number of pulses is ignored.

Pulse Length - Pulse length in milliseconds, the minimum is 1

Pulse Period - Pulse period in milliseconds, the minimum is 2

Number of Pulses - Number of pulses before the output is disabled.

Slew Rate - Sets the rate of change in amplitude, in Volts per millisecond.

Off Voltage - Output voltage when the pulse is off.

Start Button – Start and stop pulse output.

22 Frequency Modulation Mode

The frequency modulation mode will modulate the frequency around a centre frequency. The centre frequency can be fixed or variable if using phase tracking. It is compatible with power and current tracking and is recommended for cleaning applications. Note the tracking controllers only operate when the phase is equal to the phase setpoint. If the controllers lose phase lock the frequency modulation will be disabled until phase lock is established.

The screenshot shows the Frequency Modulation Mode control interface. On the left sidebar, the 'FM' mode is selected. The settings panel includes:

- Phase Tracking:
- Current Tracking:
- Power Tracking:
- Use Remote Amplitude:
- Max Power (W): 210.0
- Max Voltage (Vrms): 309.4
- Max Current (Arms): 0.66
- Transformer Turns: 18.200
- Voltage (Vrms): 42.1
- Frequency Modulation Settings:
 - Delta (\pm Hz): 1000
 - Rate (Hz/ms): 1.000
- Start Button
- Frequency (Hz): 64692.5
- Maximum (Hz): 100000
- Minimum (Hz): 20000.0
- Phase Setpoint: 0.0
- Control Gain: 0.100

Two graphs are displayed:

- Top graph: Voltage (V) and Current (A) vs Samples (0 to 500). Voltage ranges from -100 to 100 V, and Current ranges from -0.50 to 0.50 A.
- Bottom graph: Phase (deg) and Frequency (kHz) vs Time (s) (0 to 40). Phase ranges from -10 to 40 deg, and Frequency ranges from 61.00 to 66.00 kHz.

Bottom status bar shows:

- Output Voltage: 42.7 (Vrms)
- Output Current: 0.31 (Arms)
- Amplifier Power: 119.3 (W)
- Load Power: 5.1 (W)
- Temperature: 45.8 (C)
- Phase: -3.9 (deg)
- Impedance: 18.8 (Ω)
- Connected: 5147
- Disable All Button

Delta (\pm -Hz) – The amplitude of the frequency modulation.

Rate (Hz/ms) – The rate at which the frequency is modulated.

Start Button – Start and stop output.

23 Multi Device Mode

The multi device mode allows for multi PDUS210s to be controlled simultaneously. It allows for either tracking, pulse, or frequency modulation to be started simultaneously on multiple PDUS210s. It also allows for the monitoring of multiple PDUS210s. To control multiple PDUS210s all PDUS210s will need to be unlocked from the remote/front panel. Additionally, the phase tracking, current tracking, power tracking and use remote amplitude needs to be synced across all PDUS210s. If one of the PDUS210s has a overload occur all connected PDUS210s will be disabled.

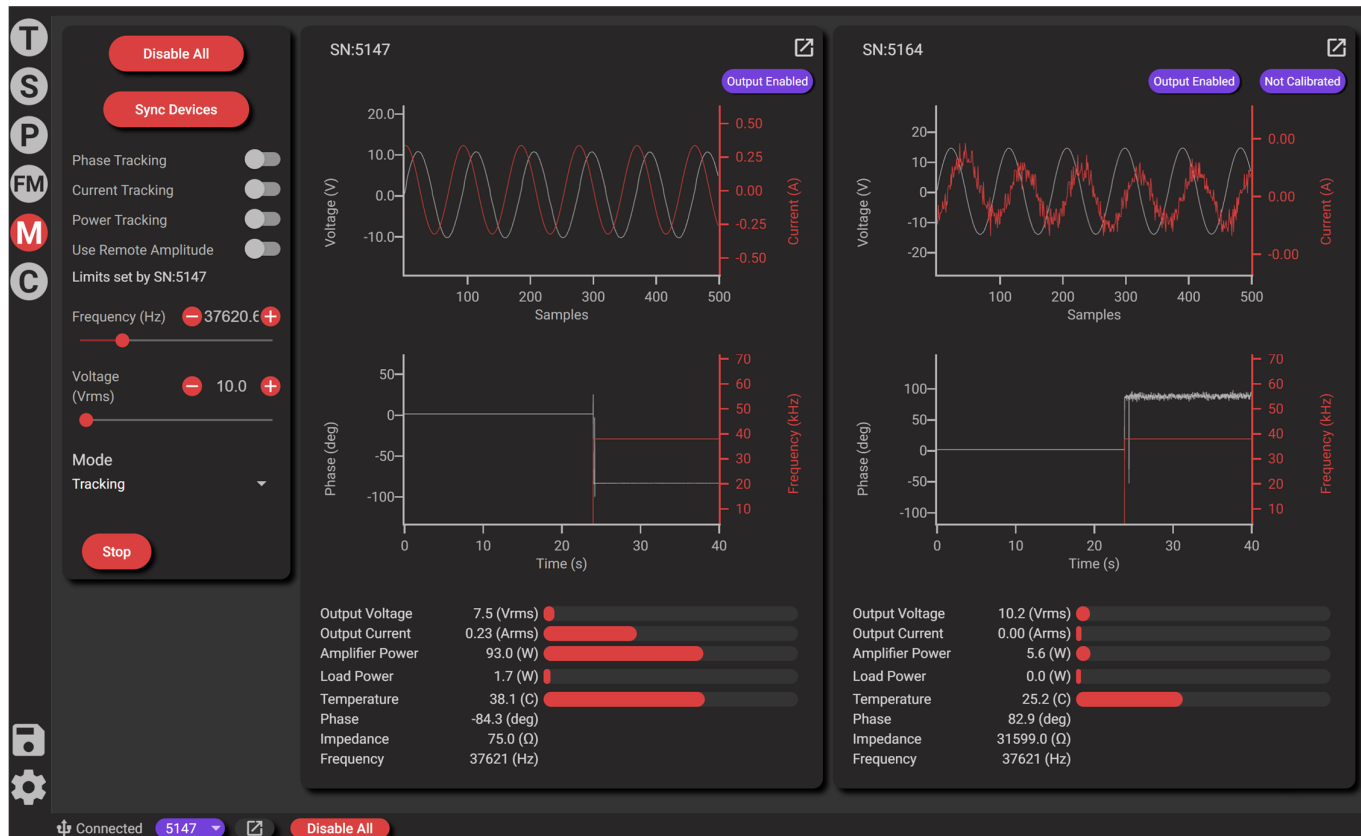

 - Will pop out a new window for this PDUS210.

Disable All – Disables all PDUS210s connected to the computer.

Sync Devices – Syncs all of the PDUS210s connected to the computer. Will set:

- Phase tracking
- Current tracking
- Power tracking
- Use remote amplitude
- Frequency
- Voltage
- Phase setpoint
- Current setpoint
- Power setpoint

to match the selected PDUS210. All other parameters including the max voltage, max current and max load power need to be set individually on each PDUS210.

Mode – Changes the mode that will be started across all connected PDUS210s. Each mode has key parameters that will be mirrored across all connected PDUS210s.

24 Calibration Mode

The screenshot shows a dark-themed interface with three main sections. Each section has a title, a list of parameters, a 'Compatible' status, and a red button.

- Calibration On Device**
 - Turns: 18.20
 - PDUS210 Serial: 5164
 - Test Load: 20.1 (Ω)
 - Date: 5/11/2023
 - Time: 10:53:47 AM
 - Clear button
 - Compatible status
- New Calibration**
 - Start button
- Load Calibration File**
 - Turns: 18.20
 - PDUS210 Serial: 5164
 - Test Load: 20.1 (Ω)
 - Date: 5/11/2023
 - Time: 10:53:47 AM
 - Compatible status
 - Load button
 - Upload button

The measured impedance will be a mix of the load's impedance and the transformers impedance. To remove the transformers impedance a calibration can be performed. The desktop software has a wizard that will walk you through the process. You will require a way to short circuit the transformer and a known resistive load. If you need assistance acquiring these please reach out to info@piezodrive.com. If you are using a flex PDUS210 you will need to recalibrate each time you change the transformer. To speed up this process you can save the calibrations to file and load them again when changing the transformer. If the PDUS210 is not calibrated it will still operate, just note that the measured impedance will be inaccurate.



Calibration On Device

Shows a summary of the current calibration loaded on the PDUS210.

Turns – The number of turns of the transformer used when the calibration was performed.

PDUS210 Serial – The serial number of the PDUS210 used to perform the calibration.

Test Load – The resistance of the known load used for calibration.

Date/time – When the calibration was performed.

Clear – Permanently removes the current calibration.

Compatible/Incompatible – The compatibility of the loaded calibration, both the number of turns and the serial number need to match the PDUS210.

New Calibration

Start/Reset – Opens or Resets calibration wizard back to the start.

Load Calibration File

Shows a summary of the current calibration opened from file.

Turns – The number of turns of the transformer used when the calibration was performed.

PDUS210 Serial – The serial number of the PDUS210 used to perform the calibration.

Test Load – The resistance of the known load used for calibration.

Date/time – When the calibration was performed.

Load – Opens a file browser to select a calibration file, will have “.json” extension.

Upload – Uploads the opened calibration file to the PDUS210, only visible if opened calibration is compatible.

Compatible/Incompatible – The compatibility of the opened calibration, both the number of turns and the serial number need to match the PDUS210.

25 Rack Mounting

The PD200X4 can be installed in a 19-inch x 2U rack space using the single unit rack kit (order code: SingleRackKit-2U).

Two amplifiers can also be installed in a side-by-side configuration using the double unit rack kit (order code: DoubleRackKit-2U). The double rack kit is assembled in the factory and includes coupling screws for the enclosure, the same handles as the single rack kit, and

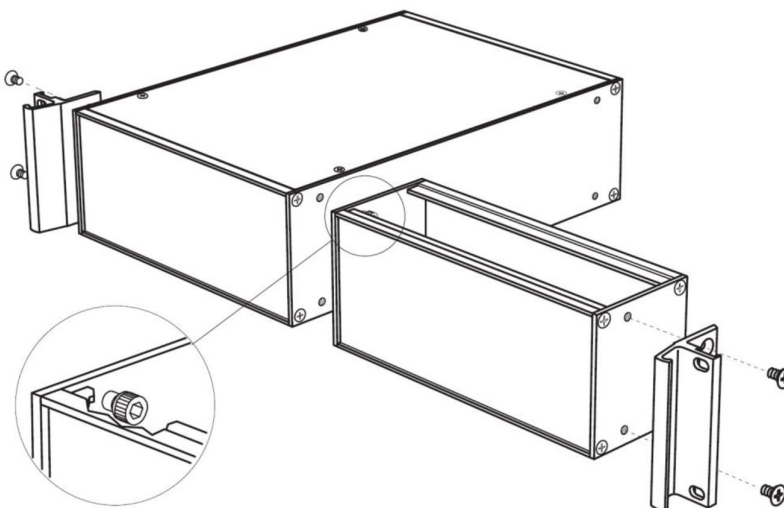

Figure 11. Single rack kit, showing the amplifier on left, and the rack adaptor on right.

26 Warranty

PiezoDrive amplifiers are guaranteed for 12 months from the date of delivery. The warranty does not cover damage due to misuse.