

PDu150CL V6

Ultra-low Noise 150V Piezo Driver with Strain Gauge Feedback

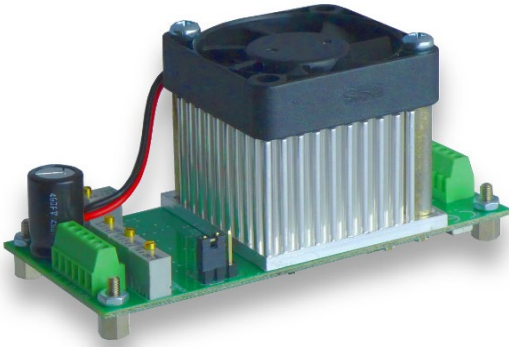

The PDu150CL combines a miniature high-voltage power supply, precision strain conditioning circuit, feedback controller, and ultra-low noise amplifier in a package the size of a credit card. It provides all of the necessary functions for high-resolution open-loop or closed-loop control of piezoelectric actuators with integrated resistive strain sensors.

The PDu150CL produces 300mA peak output current at frequencies up to 80 kHz with exceptionally low noise and is protected against short-circuit, average current overload, and excessive temperature. Passive cooling is available for low power applications or the integrated fan can be used for power dissipations above 5W. The PDu150CL can be mounted on a base structure with four M2.5 screws or directly onto a host motherboard (PDu150CL-PCB).

Specifications	
Power Supply	+24V, Ground
Output Voltage	-30V to +150V
Peak Current	300 mA
RMS Current	235 mA
Power Bandwidth	80 kHz (150 Vp-p)
Signal Bandwidth	180 kHz
Slew Rate	38 V/us
Gain	20 V/V
Input Impedance	10 kΩ (Closed loop mode) 3.05 kΩ (Open loop mode)
Input Offset	±5 mV
Load	Unlimited
Output Noise	26 uV RMS, 1uF Load, 0.03Hz to 1MHz
Protection	Short-circuit, average current, and under-voltage protection
Quiescent Current	100 mA (10 mA in Shutdown)
Connectors	Screw terminals (AWG 20-30)
Dimensions	40 x 89 x 44 mm
Environment	0 to 60°C (32 to 140°F) Non-condensing humidity
Weight	80 g

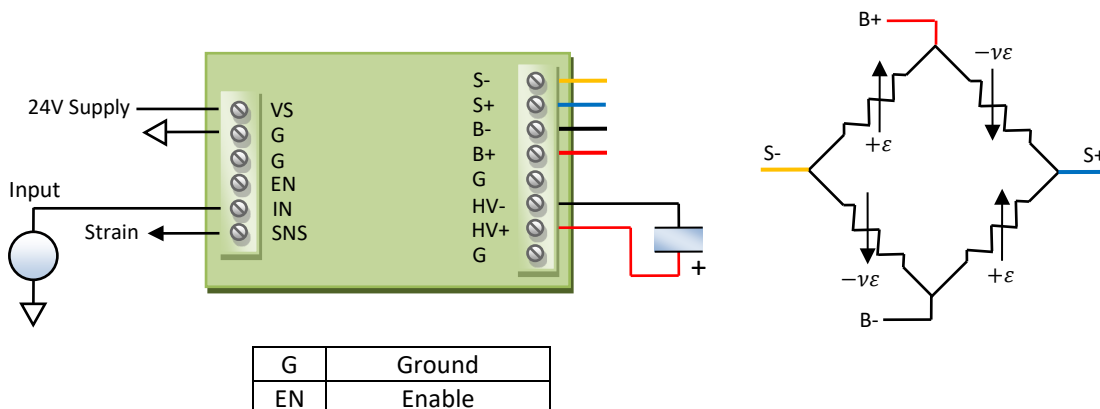

Figure 1. Basic Connection diagram

Operation

As shown in Figure 2, PDu150CL can be used in either open-loop or closed-loop modes. In the open-loop mode, the input signal is connected directly to the power amplifier. Note that the power amplifier uses a novel low-noise differential architecture that cannot be connected to ground.

In the closed-loop mode, the input signal acts as a command signal for the feedback loop. The strain signal is derived from a resistive strain gauge attached to the piezo or structure.

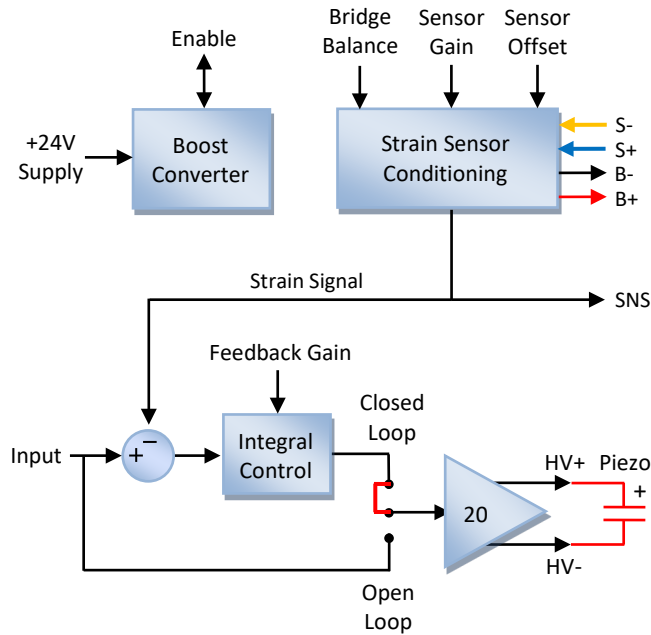

Figure 2. PDu150CL Block Diagram

Output Current

The peak output current is 300mA. In addition, the maximum average current is 105mA. The average current is useful for calculating the power dissipation and average supply current. For a sine wave, the average positive output current is equal to

$$I_{av} = \frac{\sqrt{2}}{\pi} I_{rms} = \frac{1}{\pi} I_{pk}$$

Supply Current

The quiescent power for the amplifier is approximately 2 W or 85 mA. This can be reduced to <10 mA by pulling the Enable pin low with an open collector circuit. If the fan is used, the quiescent power is increased by 0.5W,

The supply current is related to the total average output current by

$$I_s = \frac{200 \times (I_{av} + 0.010)}{24}$$

where I_{av} is the total average output current. The maximum supply current is 0.9 A at full power.

Power Bandwidth

The maximum slew-rate is 38 V/us. Therefore, the maximum frequency sine-wave is

$$f_{max} = \frac{38 \times 10^6}{\pi V_{L(p-p)}}$$

The power bandwidth for a 150 Vp-p sine-wave is 80 kHz.

With a capacitive load, the power bandwidth is limited by the output current. The maximum frequency sine-wave is

$$f_{pwr} = \frac{I_{pk}}{\pi V_{L(p-p)} C_L}$$

where I_{pk} is the peak current limit, $V_{L(p-p)}$ is the peak-to-peak output voltage, and C_L is the effective load capacitance. The power bandwidth for a range of load capacitance values is listed in Table 1.

Load (uF)	Voltage Range		
	50 V	100 V	150 V
0.03	64000	32000	21000
0.1	19000	9600	6400
0.3	6400	3200	2100
1	1900	960	640
3	640	320	210
10	190	96	64
30	64	32	21

Table 1. Power bandwidth (in Hz) with a capacitive load

The maximum peak-to-peak voltage is plotted below versus load capacitance.

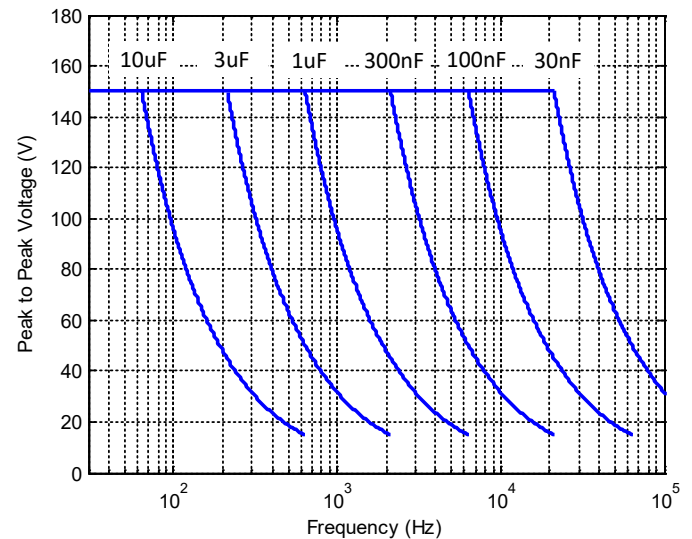

Figure 3. Power Bandwidth

Signal Bandwidth

The small-signal bandwidth for a range of capacitive loads is listed in Table 2. The small-signal frequency responses are plotted in Figure 4.

Load Capacitance	Signal Bandwidth
No Load	180 kHz
30 nF	120 kHz
100 nF	34 kHz
300 nF	11 kHz
1 uF	3.2 kHz
3 uF	980 Hz
10 uF	190 Hz
30 uF	73 Hz

Table 2. Small signal bandwidth (-3 dB)

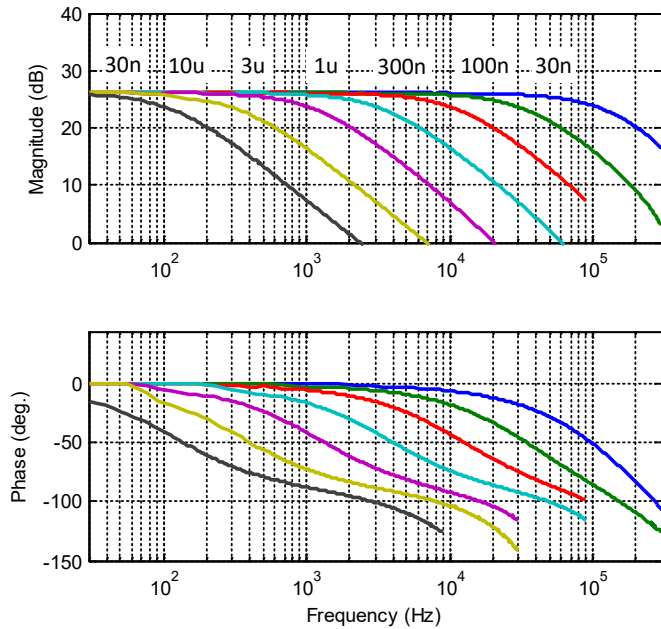

Figure 4. Small signal frequency response

Power Amplifier Noise

The output noise contains a low frequency component (0.03 Hz to 10 Hz) that is independent of the load capacitance; and a high frequency component (10 Hz to 1 MHz) that is inversely related to the load capacitance.

The noise is measured with an SR560 low-noise amplifier (Gain = 1000), oscilloscope, and an Agilent 34461A Voltmeter. The low-frequency noise is plotted in Figure 5. The RMS value is 15 uV with a peak-to-peak voltage of 100 uV.

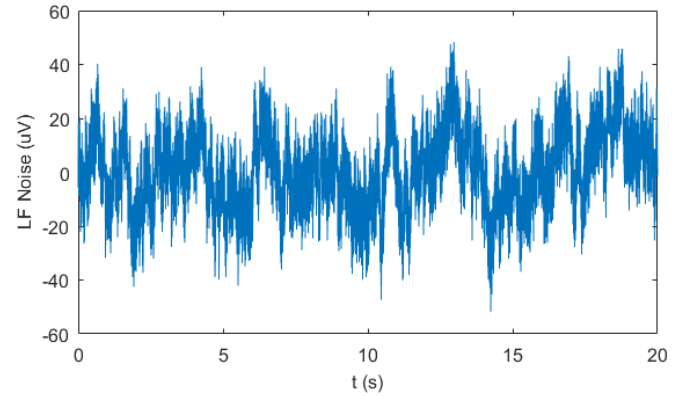

Figure 5. Low frequency output noise (0.03 Hz to 10 Hz)

The high frequency noise (10 Hz to 1 MHz) is listed in the table below versus load capacitance. The total noise from 0.03 Hz to 1 MHz is found by summing the RMS values, that is $\sigma = \sqrt{\sigma_{LF}^2 + \sigma_{HF}^2}$.

Load Capacitance	HF Noise	Total Noise
10 nF	450 uV	450 uV
30 nF	170 uV	170 uV
100 nF	60 uV	62 uV
300 nF	34 uV	37 uV
1 uF	21 uV	26 uV
3 uF	16 uV	23 uV
10 uF	16 uV	22 uV
30 uF	18 uV	23 uV

Table 3. HF Noise (10 Hz to 1 MHz) and total noise

Strain Sensor Specifications

Strain Sensor Specifications	
Bridge Excitation	6V (Differential)
Sensor Resistance	350 Ω to 1000 Ω
Sensor Configuration	Single, Half or Full Bridge
Bridge Balance Range	+/- 6 mV
Gain Range	200 to 3000
Offset Range	+/- 6 mV
Bandwidth	10 kHz
Input Noise Voltage	3 uV RMS (0.1Hz to 100Hz)

Table 4. Strain Sensor Specifications

Sensor Connection

The PDU150CL is compatible with single element strain sensors, half-bridges, and full-bridge sensor arrangements. The advantages of these different arrangements and the recommended methods of connection are described in the following. Suitable strain sensors are available from many suppliers, including www.omega.com.

Single Element Strain Gauge

Single element strain sensors can be useful in applications where the temperature is stable or simplicity is a priority. As shown below, the recommended configuration requires three dummy resistors (R) equal in resistance to the strain gauge. The best temperature stability is achieved when the dummy resistors have the same temperature coefficient as the strain gauge and are thermally connected to the strain gauge.

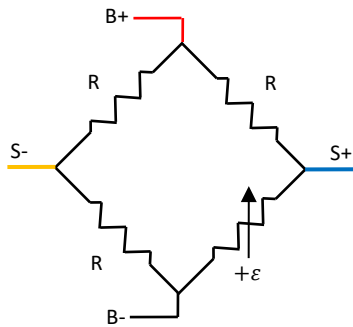

Half Bridge Strain Sensor

A half bridge arrangement with a 90 degree rosette sensor provides good immunity to temperature variation and approximately 30% better resolution than a single element. The recommended configuration requires two dummy resistors (R) that are equal in value to the strain gauge resistance.

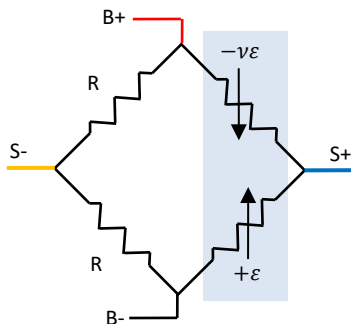

The strain element aligned to the piezo expansion is denoted by $+\epsilon$ and the 90 degree element is denoted $-\nu\epsilon$. This convention is adopted since a positive strain in the piezo $+\epsilon$ causes a negative resistance change in the 90 degree element due to Poisson's ratio (ν).

Full Bridge Strain Sensor

A full-bridge arrangement constructed from two 90 degree rosette sensors provides good immunity to temperature variation, the best linearity, and twice the resolution of a half bridge; however, this configuration also requires more wiring. Actuators with full-bridge strain sensors are available from www.piezodrive.com

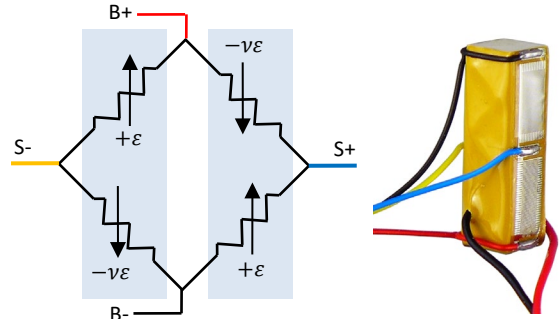

The strain elements aligned with the direction of piezo expansion are denoted by $+\epsilon$ and the 90 degree elements are denoted $-\nu\epsilon$. This convention is adopted since a positive strain in the piezo $+\epsilon$ causes a negative resistance change in the 90 degree element due to Poisson's ratio (ν). Note that the mounting of the two rosette sensors are opposite.

Sensor Noise and Resolution

Since the sensor noise is filtered by the complementary sensitivity function of the control loop, the bandwidth of interest is typically 0.1Hz to 100Hz. The upper frequency limit has little effect since the majority of noise in this bandwidth is due to low-frequency noise from the on-board references and primary gain stage. With a bridge resistance of 350 Ohms, the total input referred noise voltage is plotted below, the RMS value is 3uV with a peak-to-peak voltage of 20uV.

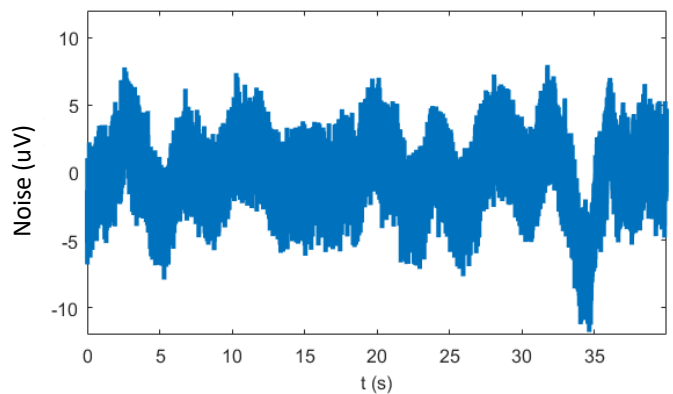

Figure 6. Total noise with a 350 Ohm Bridge (0.1Hz to 100Hz)

The sensor noise can be used to estimate the sensor resolution. The induced voltage for a two-varying element full bridge is [1, 2]

$$V_s = \frac{1}{2} V_e GF \varepsilon (1 + \nu)$$

Where V_e is the excitation voltage (5V), GF is the gauge factor (typically ~ 2), ε is the strain, and ν is the Poisson's ratio (0.34 for PZT5H). For a full-scale strain of 0.1%, the expected bridge voltage is 6.7 mV. Therefore, the expected RMS resolution is

$$\text{Resolution} = \frac{3 \text{ uV}}{6.7 \text{ mV}} = 0.045\% \text{ of Full Scale}$$

Sensor Calibration Procedure

The following procedures are required to calibrate the bridge conditioning circuit and should be performed with the sensor and piezo connected to the PDU150CL.

Balance the Bridge

Small mismatches in the bridge resistances can be accounted for by the "Bridge Balance" pot. This step optimizes the temperature sensitivity of the bridge circuit.

- 1) Place the PDU150CL in "Open-Loop" mode and apply 0V or a short-circuit to the input terminals.
- 2) Connect a voltmeter between the **S-** and **S+** terminals (without disconnecting the bridge).
- 3) Tune the "Bridge Balance" pot until the measured voltage is zero.

Set the Sensitivity and Offset

This step calibrates the sensor so that a 0V to 150V signal applied to the piezo produces a 0V to 10V strain signal.

- 1) Turn the "Sensor Gain" pot fully anti-clockwise, (10 turns).
- 2) Ensure the PDU150CL is in "Open-Loop" mode and apply 0V or a short-circuit to the input terminals.
- 3) Monitor the **SNS** terminal and tune the "Sensor Offset" pot until the voltage is zero.
- 4) Apply 7.5V to the input terminal to generate 150V across the piezo.
- 5) Monitor the **SNS** terminal and tune the "Sensor Gain" pot until the voltage is +10V.

Variations

Many variations of the above procedure are possible. Some useful options are listed below.

The offset and gain can be tuned simultaneously by applying a 5-Hz sine wave to the input terminals with a range of 0V to 7.5V, which results in 0V to 150V across the piezo. Monitor the **SNS** terminal with an oscilloscope and tune the "Sensor Offset" and "Sensor Gain" pots until the measured sine-wave is between 0V and 10V.

Rather than calibrating the sensor to +10V at full scale, another voltage such as +5V may be more desirable.

If negative voltages across the piezo are acceptable, it is convenient to calibrate the full piezo voltage range, e.g. -30V to +150V, to a **SNS** voltage of 0V to +10V. This

requires an input of -1.5V to +7.5V during calibration, rather than 0V to +7.5V.

For stack actuators with different voltage ratings, the calibration input signal should be chosen accordingly. For example, a suitable calibration input for a piezo with a voltage rating -20V to +100V would be -1V to +5V.

Closed-Loop Operation

Once the sensor is calibrated, the PDU150CL can be placed in closed-loop mode. The structure of the closed-loop system is illustrated below.

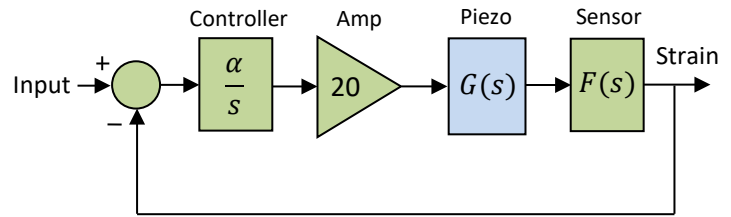

Figure 7. Feedback structure of the PDU150CL

The closed-loop sensitivity is defined by the sensitivity of the strain sensor. For example, if the piezo has a full-scale range (FSR) of 20 μm and the strain sensor is calibrated for 0V to 10V, the closed loop sensitivity is

$$\text{Sensitivity} = \frac{\text{FSR}}{10\text{V}} = 2 \mu\text{m/V}$$

Calibrating the Feedback Gain

The feedback gain defines the closed-loop bandwidth and settling time of the system. It is usually advantageous to choose the lowest satisfactory feedback gain to avoid unnecessary sensor noise. A simple calibration procedure is described in the following:

- 1) Turn the "Feedback Gain" pot fully anti-clockwise (10 turns).
- 2) Place the PDU150CL in closed-loop mode and apply a 1Vp-p triangle wave with a 5V offset to the input terminal. If the sensor was calibrated with a full scale range other than 10V, use an offset voltage equal to mid-range.
- 3) Monitor the input signal and **SNS** terminal with an oscilloscope and increase the feedback gain until the point where overshoot begins to occur.

For applications that do not require high-speed tracking, the above procedure is not required. The minimum feedback gain is suitable.

To achieve a specific -3dB bandwidth, replace the triangle wave with a sine-wave and tune the feedback gain until the amplitude of the **SNS** signal is 0.7Vp-p.

Headroom

When the full-scale range of the sensor is calibrated to the full-scale range of the piezo, some consideration for ‘headroom’ is required. To allow the control loop to compensate for effects such as thermal drift and creep, the input signal is typically restricted to a range of 10% to 90% so that the control-loop can utilize the remaining 10% at the lower and upper extremes. For example, a system with a full-scale range of 0V to 10V, would have a practical closed-loop input range of 1V to 9V.

An alternative to the above approach is to account for headroom during calibration. For example, rather than using the full scale range for calibration, e.g. -30V to +150V, a smaller range can be chosen, e.g. -15V to +130V. By using this method, the resulting closed-loop input range will be 0V to 10V, which may be more desirable than 1V to 9V.

Example Application

In this example, an SCL050518 stack actuator with full-bridge strain sensor is operated in closed-loop. The actuator develops a displacement of 20µm at 150V and utilizes a full-bridge strain sensor constructed from two 90 degree rosettes.

The PDU150CL was calibrated so that an applied voltage of 0V to 150V corresponds to a strain signal of 0V to 10V. The feedback gain was then chosen to achieve good tracking performance with a 10-Hz full-range triangle wave, as shown in Figure 9.

The open- and closed-loop responses to a full-range 1-Hz sine-wave input are plotted in Figure 10. Excellent compensation of hysteresis can be observed.

Before evaluating the total positioning noise, the feedback gain is adjusted to provide a closed-loop bandwidth of precisely 20 Hz by applying a 20-Hz sine-wave and varying the feedback gain until the amplitude response is -3dB. This allows a direct comparison to other methods with an identical bandwidth.

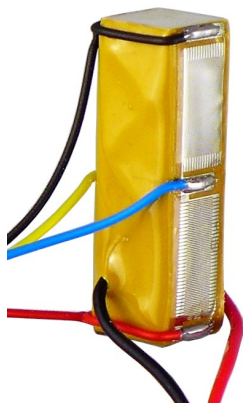

Figure 8. SCL050518 Actuator

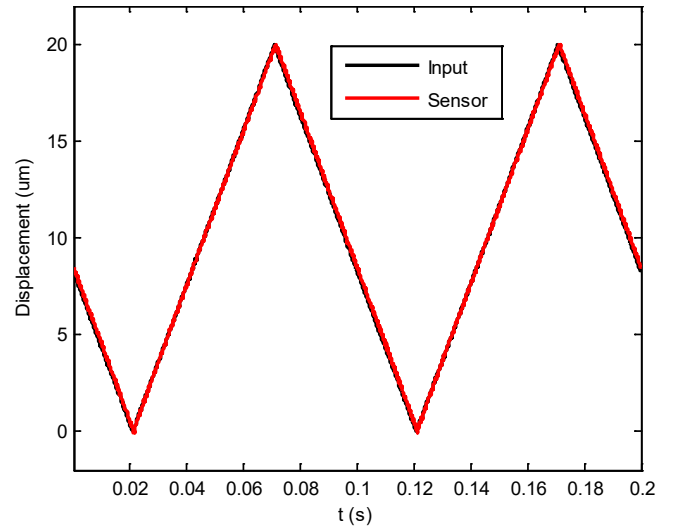

Figure 9. 10-Hz Full-Range Tracking Performance

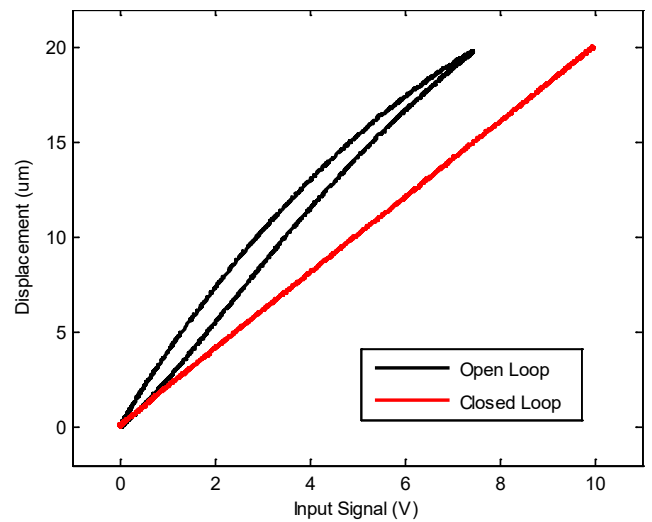

Figure 10. Open- and Closed-Loop response (1-Hz Sinusoid)

The total positioning noise due to the amplifier, sensor, and feedback controller can then be quantified by measuring the differential output voltage of the power amplifier with a zero volt input [3].

The differential output voltage was measured using an SR560 low-noise amplifier with a gain of 10 and a passband of 0.03 Hz to 1 MHz. The resulting voltage was scaled by the sensitivity of the piezo (20µm/150V) and is plotted in Figure 11. The RMS value is 8.8 nm with a peak-to-peak value of 60 nm over 50 seconds. This represents an RMS resolution of

$$\text{Resolution} = \frac{8.8 \text{ nm}}{20 \text{ µm}} = 0.044\% \text{ of Full Scale}$$

This value agrees with the predicted resolution in “Sensor Noise and Resolution”.

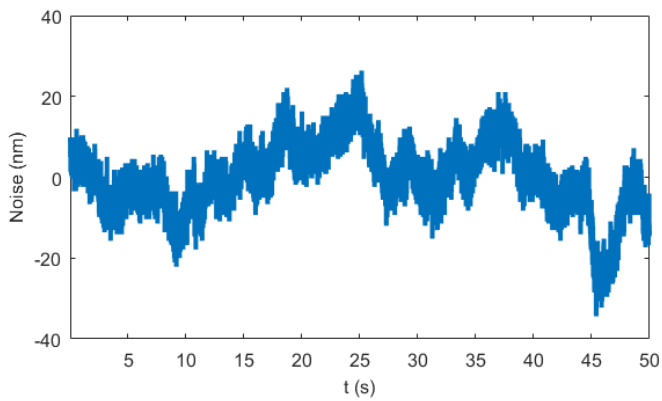

Figure 11. Closed-loop positioning noise (0.03Hz to 1MHz)

Overload Protection / Shutdown

The PDu150CL is protected against short-circuit and average current overload.

The amplifier can be shutdown manually by pulling the Enable pin low with an open-collector, or open-drain circuit. The Enable pin normally floats at 5V and should not be driven directly.

Heat Dissipation

The heat dissipation is approximately

$$P_d = 200 \times (I_{av} + 0.010).$$

For example, with a sinusoidal output, the power is

$$P_d = 200 \times (V_{L(p-p)} C_L f + 0.010).$$

For low-current applications that dissipate less than 5W, the heatsink fan may be removed. If the power dissipation is above 5W, forced air or the included fan is required.

Safety

This device produces hazardous potentials and should be used by suitably qualified personnel. Do not operate the device when there are exposed conductors.

Parts of the circuit may store charge so precautions must also be taken when the device is not powered.



Dimensions

The mounting posts accept M2.5 screws. The PCB mounting version (PDu150CL-PCB) is supplied with pins rather than screw terminals and is designed to be mounted directly onto a host motherboard. A schematic and footprint library are available for Altium Designer. Contact info@piezodrive.com to receive the file.

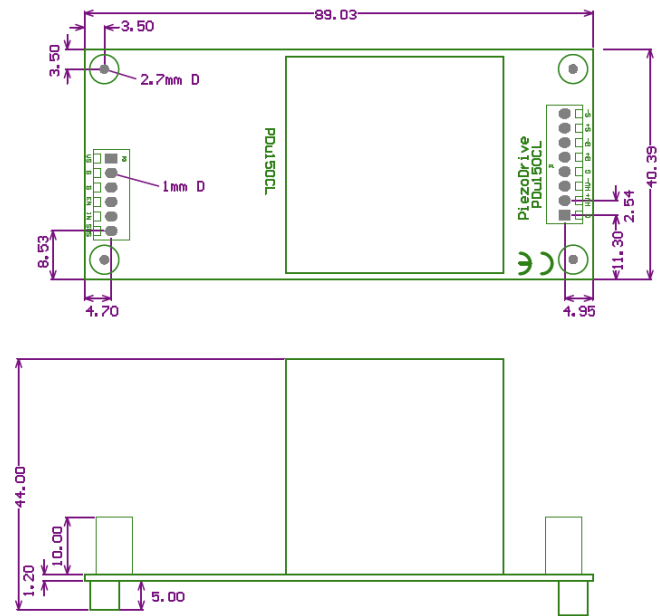

Figure 12. Dimensions (mm)

Contact / Support

info@piezodrive.com

References

- [1] *A Review of Nanometer Resolution Position Sensors: Operation and Performance*; A. J. Fleming; Sensors and Actuators A: Physical; 2013, 190, 106-126
- [2] *Design, Modeling and Control of Nanopositioning Systems*; A. J. Fleming & K. K. Leang; Springer, 2014
- [3] *Measuring and Predicting Resolution in Nanopositioning Systems*; A. J. Fleming; Mechatronics; 2014, 24, 605-618

Revision History

Date	Rev	By	Changes
24/10/23	V6 R1	KB	Bridge voltage updated
16/01/21	V5 R2	KB	Temp range updated