



Micromechanics Inc.

200 Innovation Blvd., Suite 155 ; State College, PA 16803-6602, USA
Phone: (814) 861-5688 ; Fax: (814) 861-1418. www.mmech.com

Product Specifications

Product Number: PT A 020 XXX IP

Product Description: 20W Series Step-Down Piezoelectric Transformer

1. Aspect and Dimensions

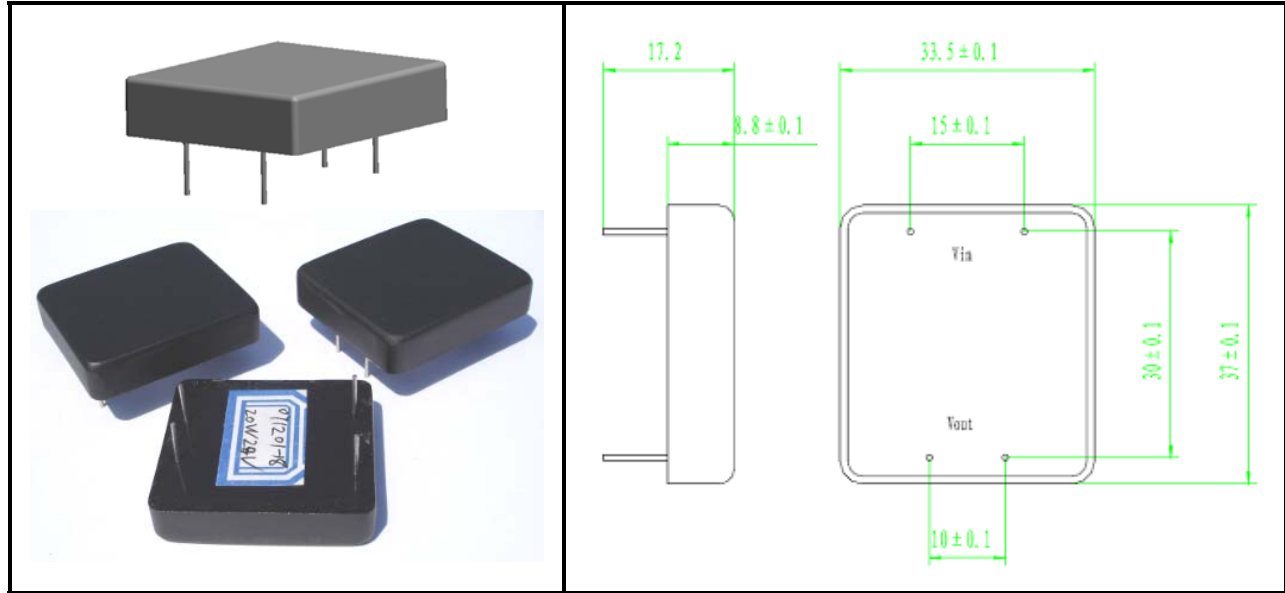

2. Product Number Guide

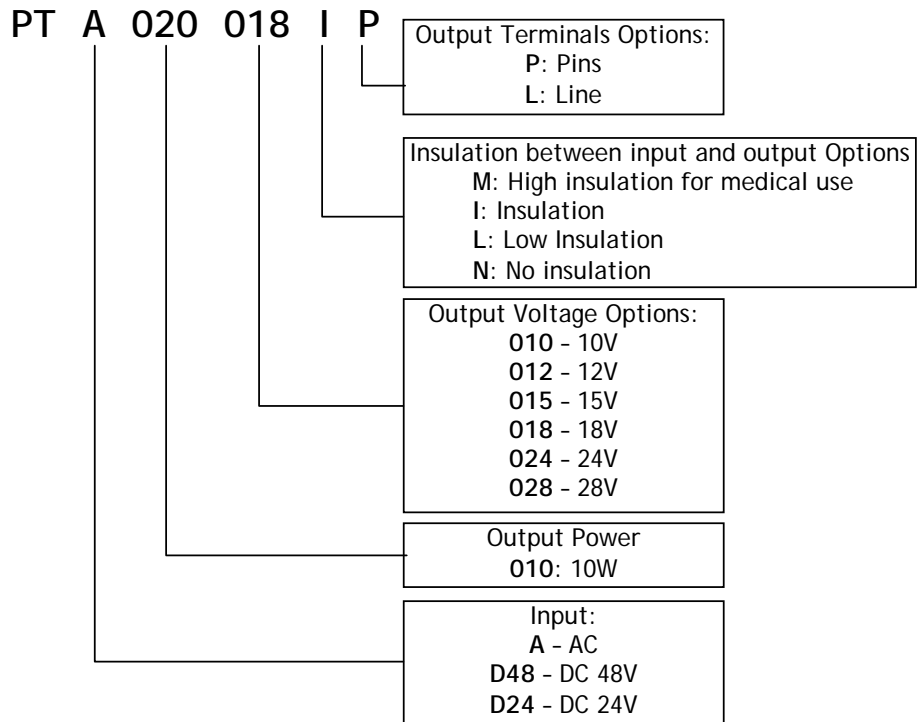



Micromechatronics Inc.

200 Innovation Blvd., Suite 155 ; State College, PA 16803-6602, USA
 Phone: (814) 861-5688 ; Fax: (814) 861-1418. www.mmech.com

3. Selection Table

Table 3.1 Family of Step down PTs.

Output Voltage	Output Power				
	5W	10W	20W	30W	50W
10V	PTA005010IP	PTA010010IP	PTA020010IP	PTA030010IP	PTA050010IP
12V	PTA005012IP	PTA010012IP	PTA020012IP	PTA030012IP	PTA050012IP
15V	PTA005015IP	PTA010015IP	PTA020015IP	PTA030015IP	PTA050015IP
18V	PTA005018IP	PTA010018IP	PTA020018IP	PTA030018IP	PTA050018IP
20V			PTA020020IP	PTA030020IP	PTA050020IP
24V	PTA005024IP	PTA010024IP	PTA020024IP	PTA030024IP	PTA050024IP
28V			PTA020028IP	PTA030028IP	PTA050028IP

(*) Highlighted the 20W series covered in this Data Sheet.

4. Electrical Characteristics - 20W Series

Table 4.1 Electrical characteristic

Parameter	Symbol	Specification		Remarks	
Output Power Rating	Pout	20W		Temperature rise is < 20°C	
Operating Temperature Range	T	-55 ~ 125°C		Tested on the PT metal case	
Dielectric Strength between input and output	V	> 3700 Vdc		Current < 20uA	
Output Voltage Rating	Vout	10V	Part No: 020010		
		15V	Part No: 020015		
		18V	Part No: 020018		
		20V	Part No: 020020		
		24V	Part No: 020024		
		28V	Part No: 020028		
Recommended Working Frequency Window	Freq	88 ~ 92 kHz			
Input Voltage Window	Vin	50 ~ 70 V	Part No: 020010	Measured at T _{room}	
		65 ~ 85 V	Part No: 020015		
		55 ~ 75 V	Part No: 020018		
		60 ~ 80 V	Part No: 020020		
		60 ~ 80 V	Part No: 020024		
		60 ~ 80 V	Part No: 020028		
Input Static Capacitance	Cin	11.5pF ± 10%	Part No: 020010	Measured at T _{room}	
			Part No: 020015		
			Part No: 020018		
			Part No: 020020		
			Part No: 020024		
			Part No: 020028		
Output Static Capacitance	Cout	300 nF ± 10%	Part No: 020010	Measured at T _{room}	
			130 nF ± 10%		Part No: 020015
			85 nF ± 10%		Part No: 020018
			75 nF ± 10%		Part No: 020020
			55 nF ± 10%		Part No: 020024
			38 nF ± 10%		Part No: 020028

5. Test Circuits

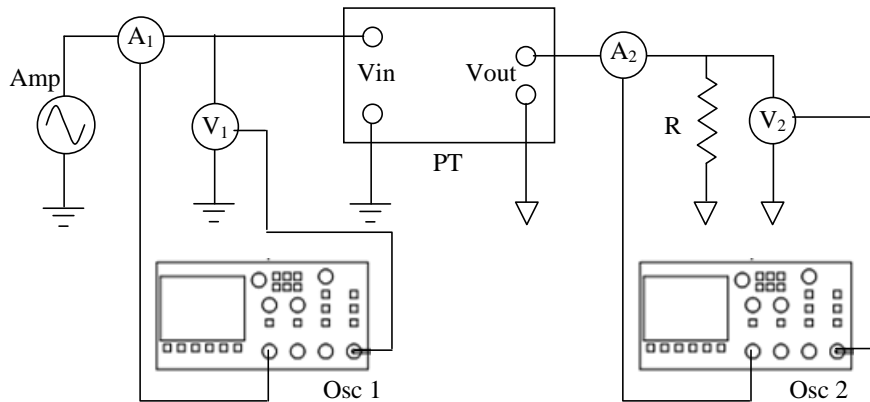

Fig. 5.1 Test circuit

Amp	Amplifier	NF HSA4052
Osc 1	Oscilloscope	Tektronix TDS754D
Osc 2	Oscilloscope	Tektronix TDS754D
A ₁	Current Probe Input Current	Tektronix TCP202
V ₁	Voltage Probe Input Voltage	Tektronix P5100
A ₂	Current Probe Input Current	Tektronix TCP202
V ₂	Voltage Probe Input Voltage	Tektronix P5100
R	Load Resistor	

6. Handling Precautions

6.1 High Voltage

The voltage gain (V_{out}/V_{in}) of a piezoelectric transformer (PT) naturally increases when the output load tends to open circuit. As such, operating a piezoelectric transformer with the output terminals open circuited may lead to higher voltages than those nominally rated. Such a high voltage may damage the transformer and, in some cases, be dangerous to the user. Consequently, when measuring or using the PT under open circuit conditions, user is advised to keep the input voltage as low as possible to avoid any damage. When designing a circuit, an open circuit protection should be considered.

6.2 Storage and transport

- a. Avoid placing the unit under dusty environments or under gas corrosive atmospheres.
- b. Keep the product in a packing material during the delivery. The product should not gain a load (weight) when you take it from the package or when you pile it up.

7. Characteristics of the PTA020010IP (Pout=20W and Vout=10V)

7.1 Voltage Gain (Vout/Vin) versus Output Load

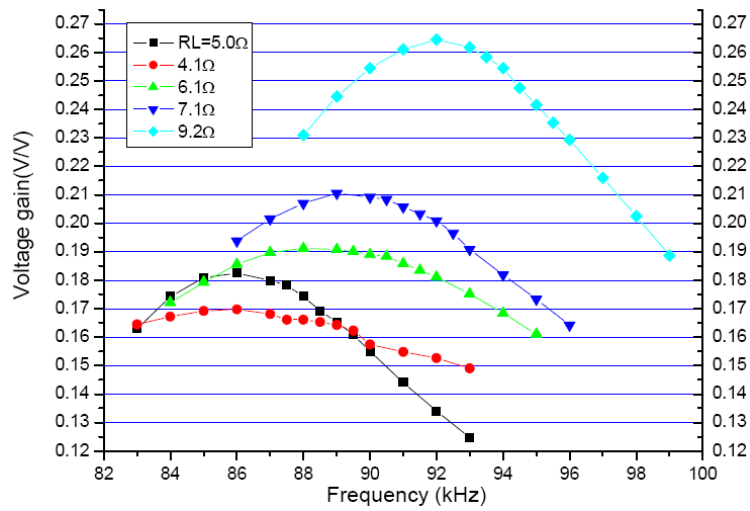

7.2 Voltage Gain under Open Circuit Conditions

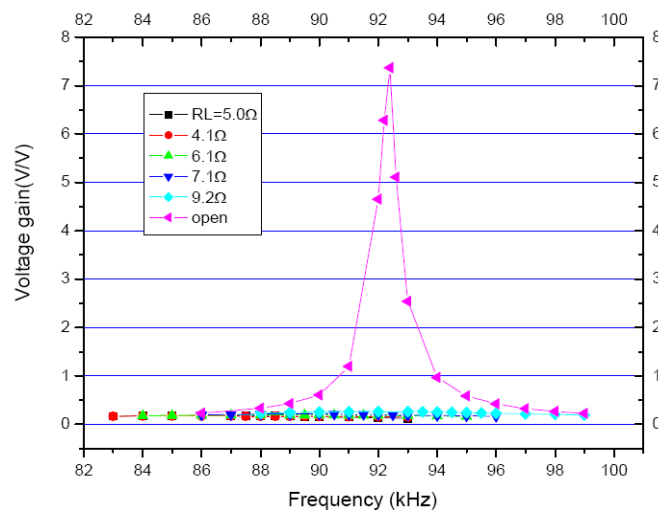

7.3 Variation of resonance frequency with the load

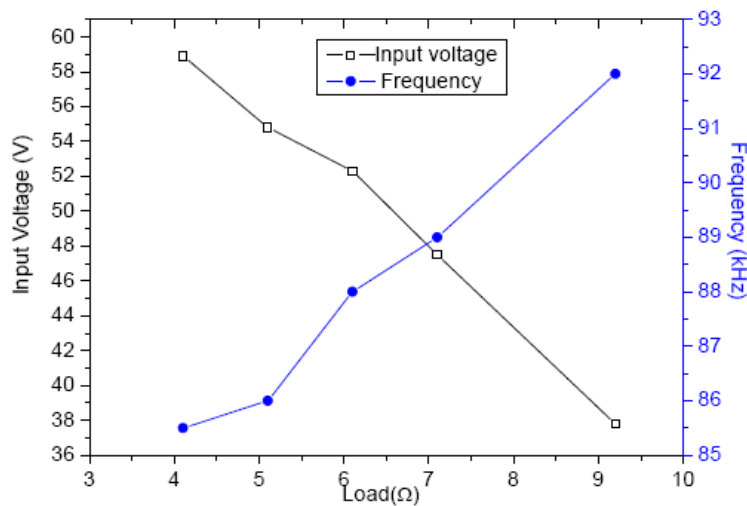

7.4 Temperature Characteristics

Variation of V_{in} , f_{res} with the Temperature

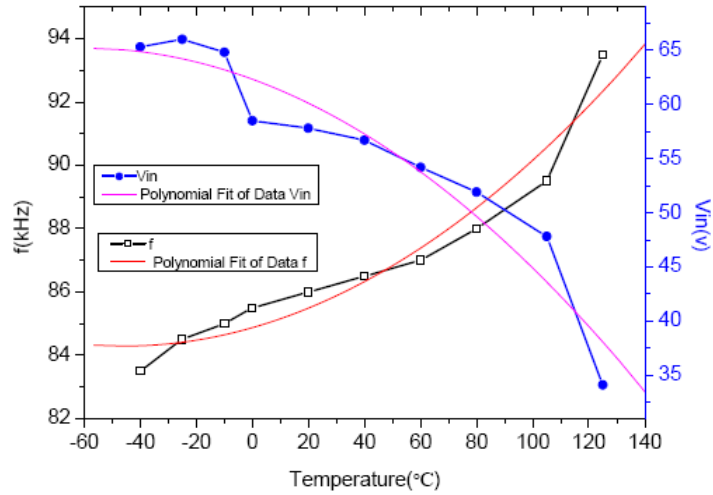

Variation of the input and output capacitances with the Temperature

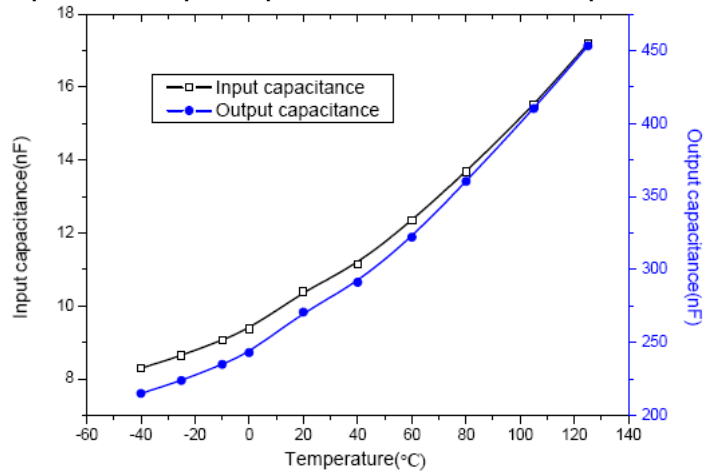

8. Characteristics of the PTA020015IP (Pout=20W and Vout=15V)

8.1 Response under load conditions

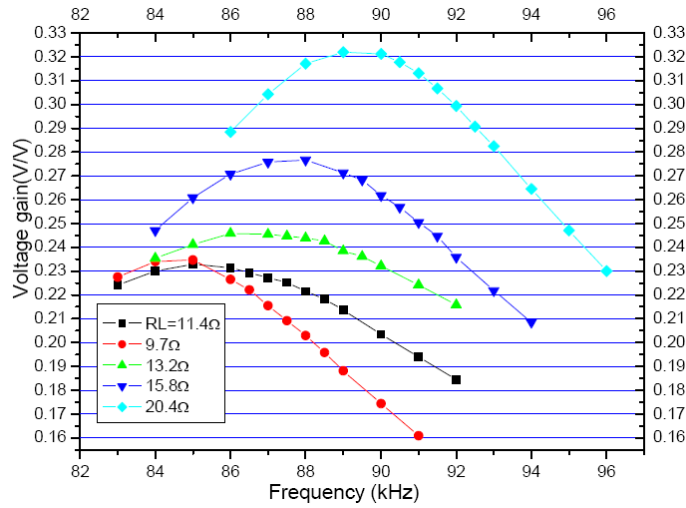

8.2 Voltage Gain under Open Circuit Conditions

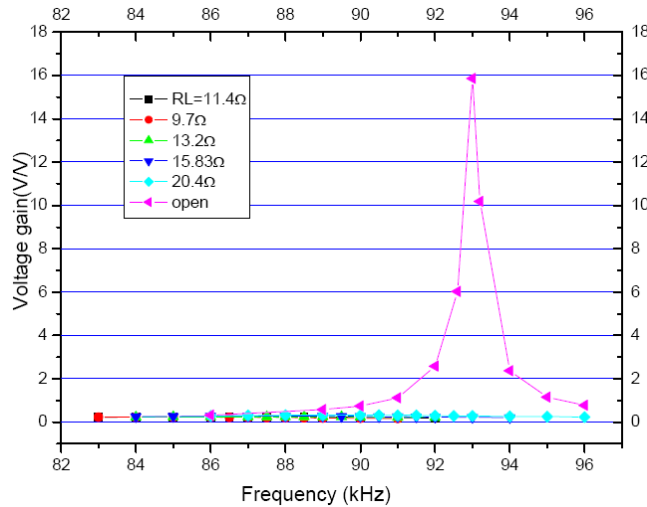

8.3 Variation of resonance frequency with the load

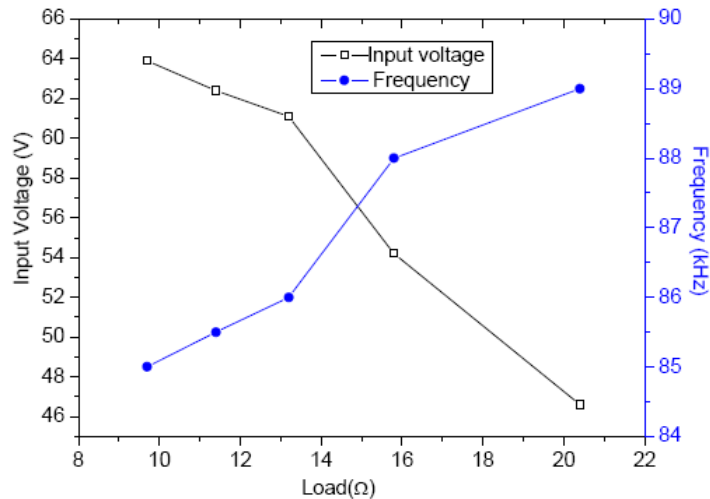

8.4 Variation of V_{in} , f_{res} with the Temperature

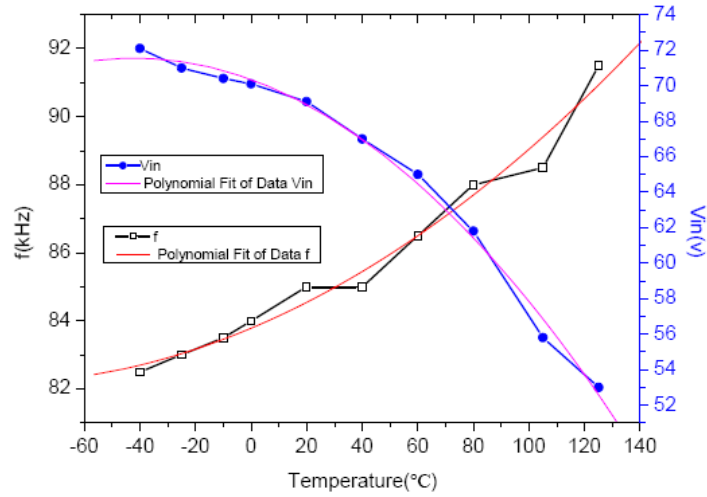

8.5 Variation of the input and output capacitances with the Temperature

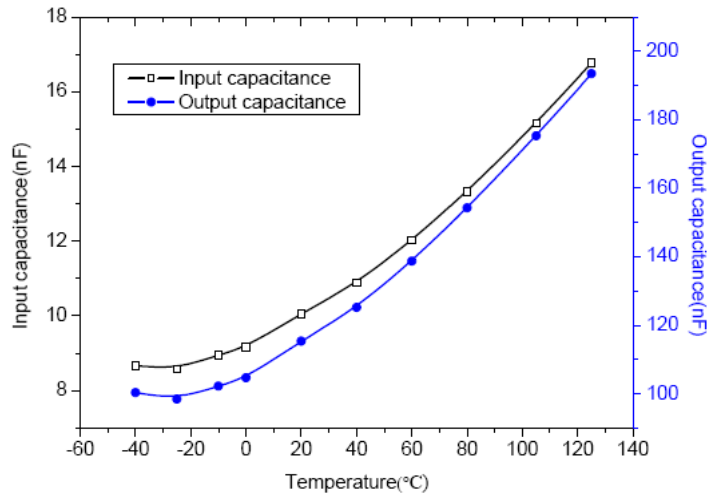

9. Characteristics of the PTA020018IP (Pout=20W and Vout=18V)

9.1 Response under load conditions

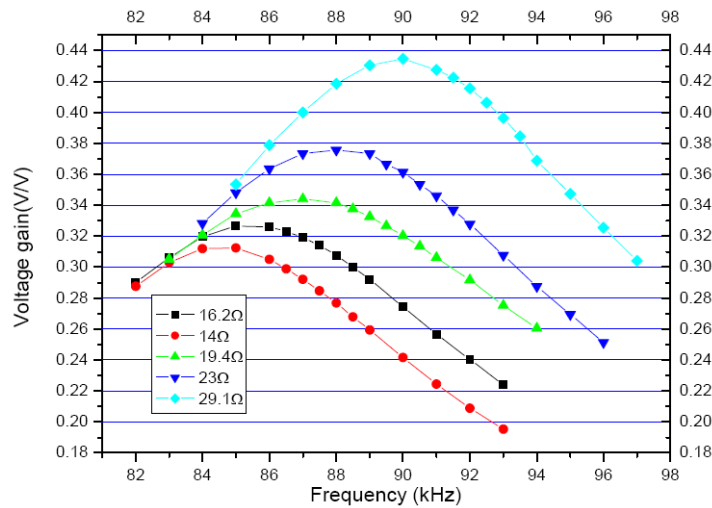

9.2 Voltage Gain under Open Circuit Conditions

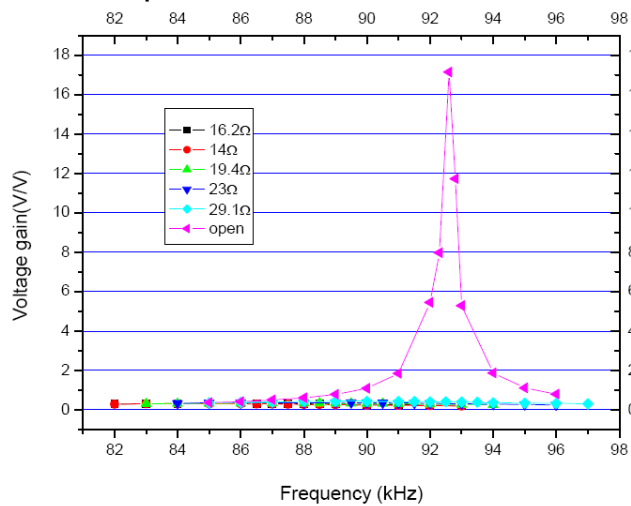

9.3 Variation of resonance frequency with the load

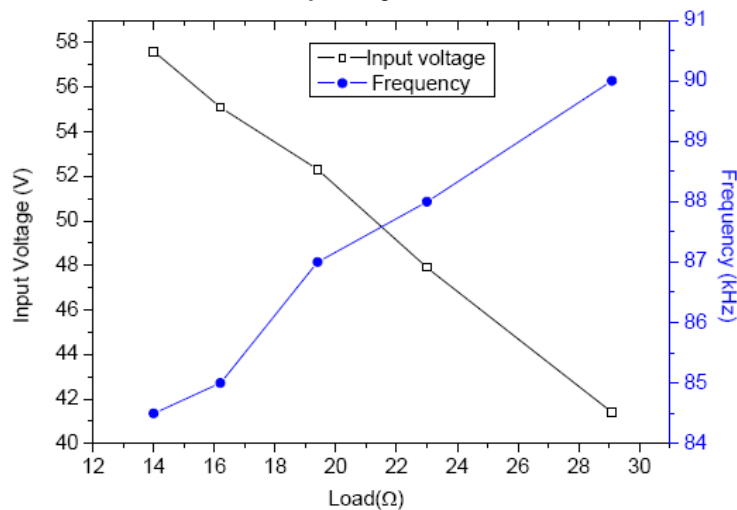

9.4 Variation of V_{in} , f_{res} with the Temperature

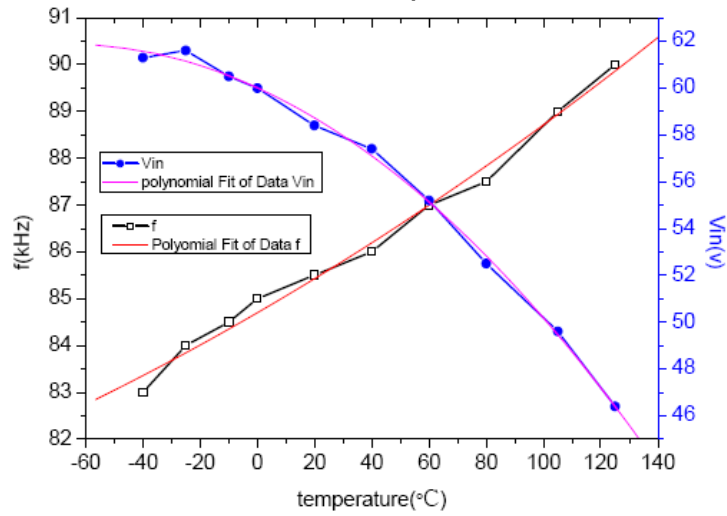

9.5 Variation of the input and output capacitances with the Temperature

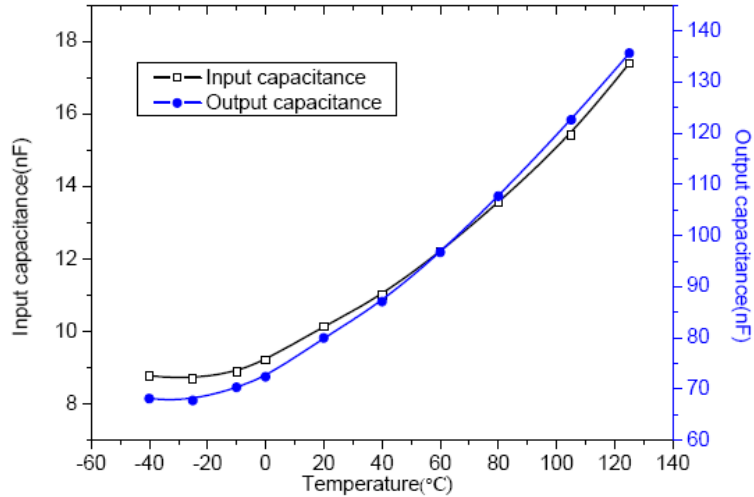

10. Characteristics of the PTA020020IP (Pout=20W and Vout=20V)

10.1 Response under load conditions

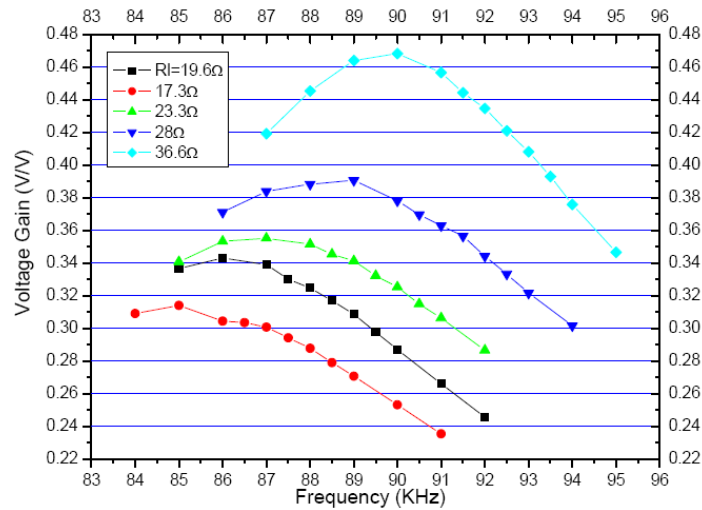

10.2 Voltage Gain under Open Circuit Conditions

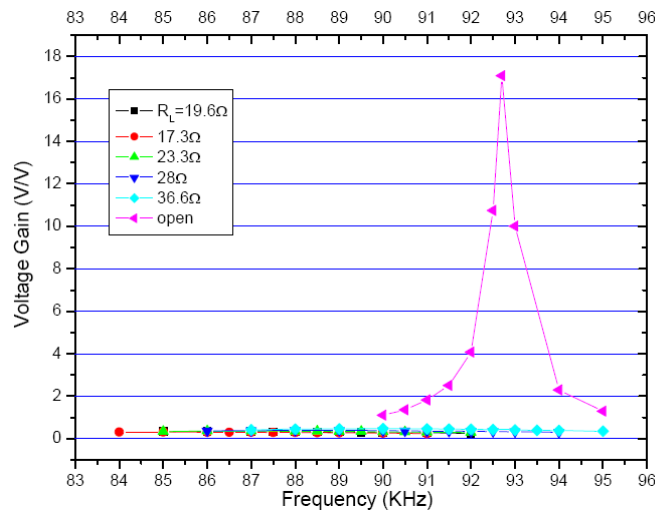

10.3 Variation of resonance frequency with the load

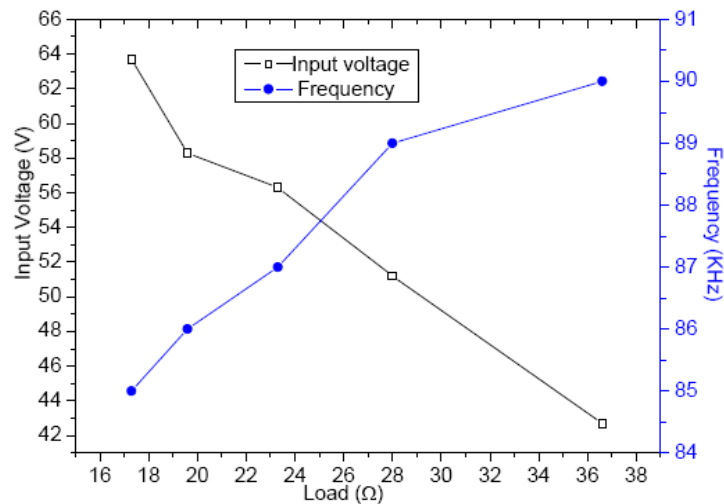

10.4 Temperature Characteristics

Variation of V_{in} , f_{res} with the Temperature

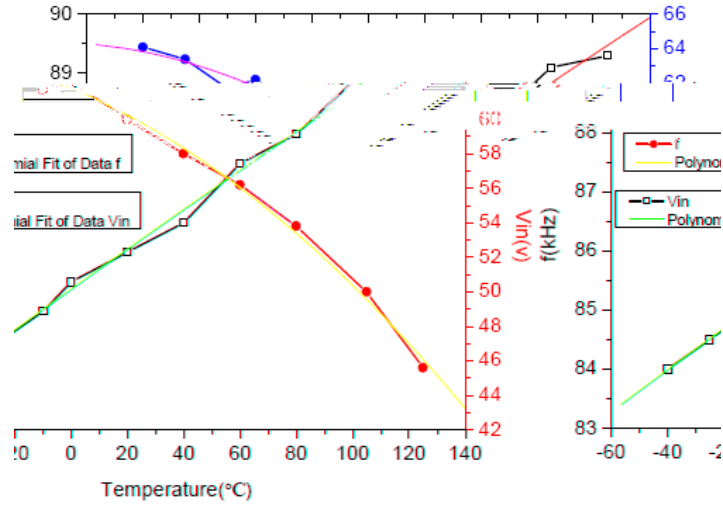

Variation of the input and output capacitances with the Temperature

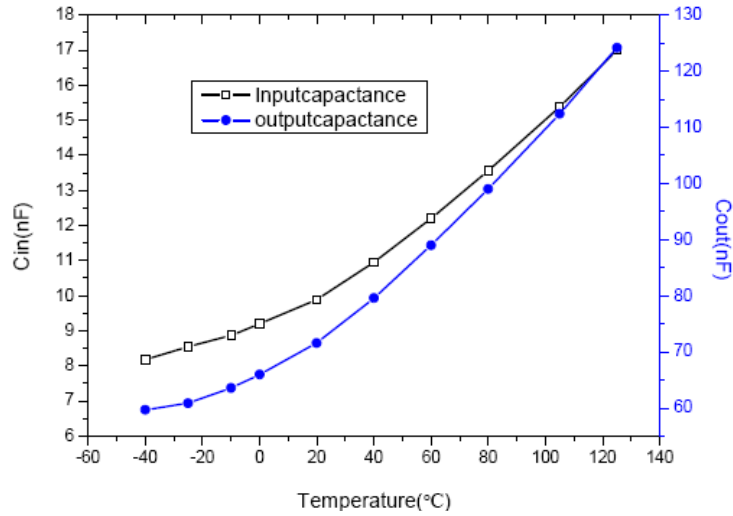

11. Characteristics of the PTA020024IP (Pout=20W and Vout=24V)

11.1 Response under load conditions

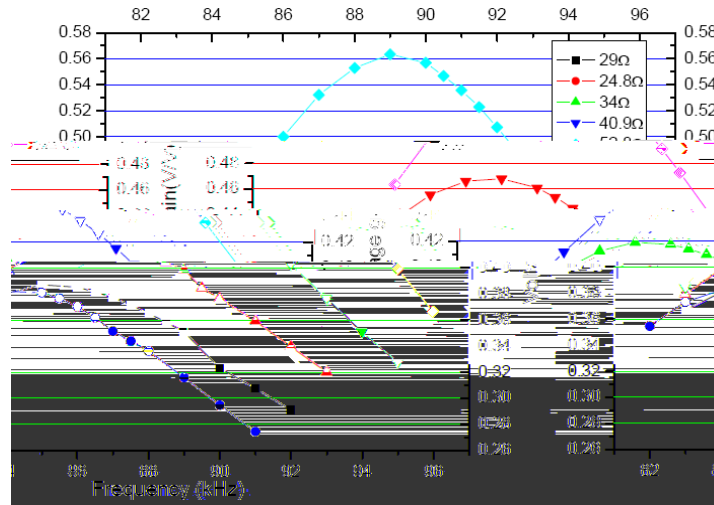

11.2 Voltage Gain under Open Circuit Conditions

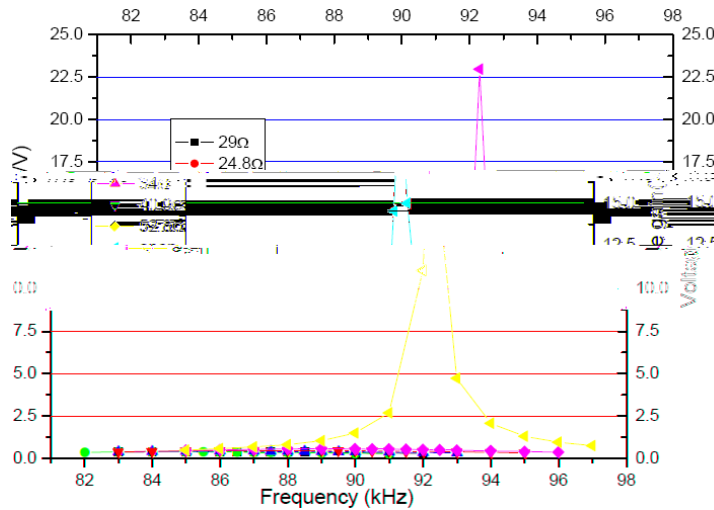

11.3 Variation of resonance frequency with the load

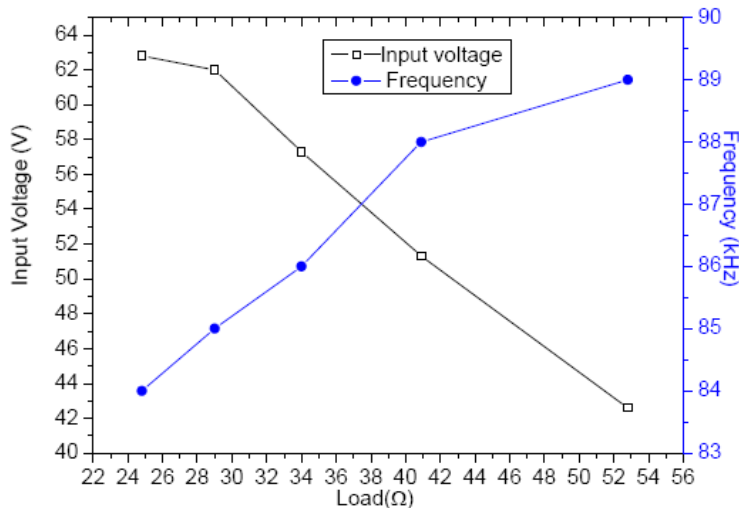

11.4 Temperature Characteristics

Variation of V_{in} , f_{res} with the Temperature

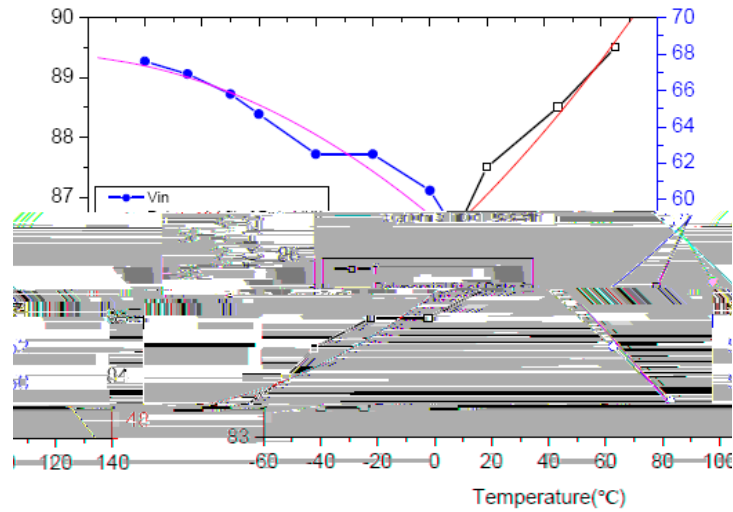

Variation of the input and output capacitances with the Temperature

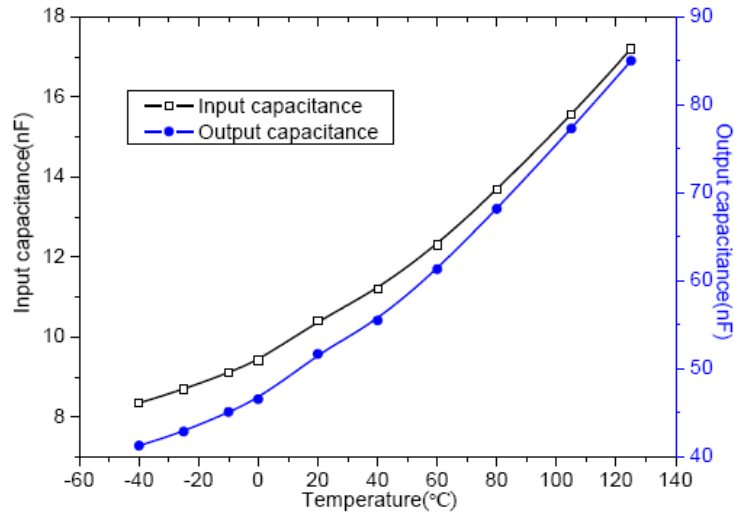

12. Characteristics of the PTA020028IP (Pout=20W and Vout=28V)

12.1 Response under load conditions

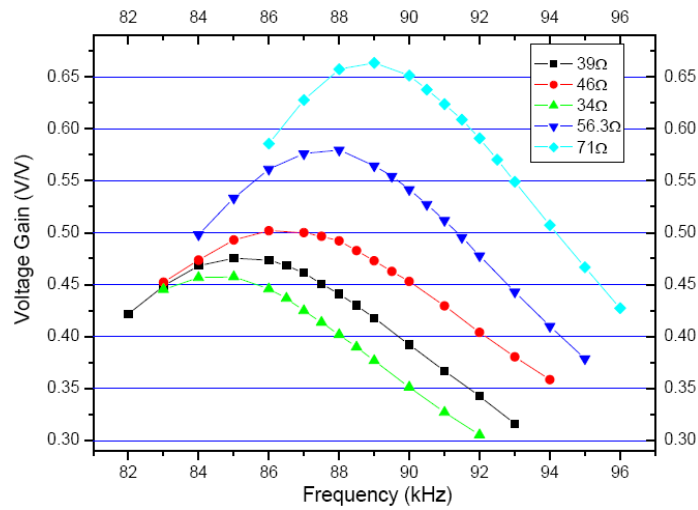

12.2 Voltage Gain under Open Circuit Conditions

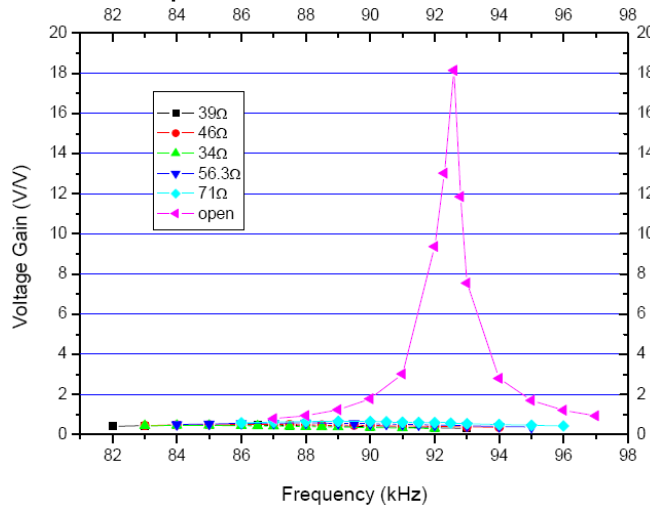

12.3 Variation of resonance frequency with the load

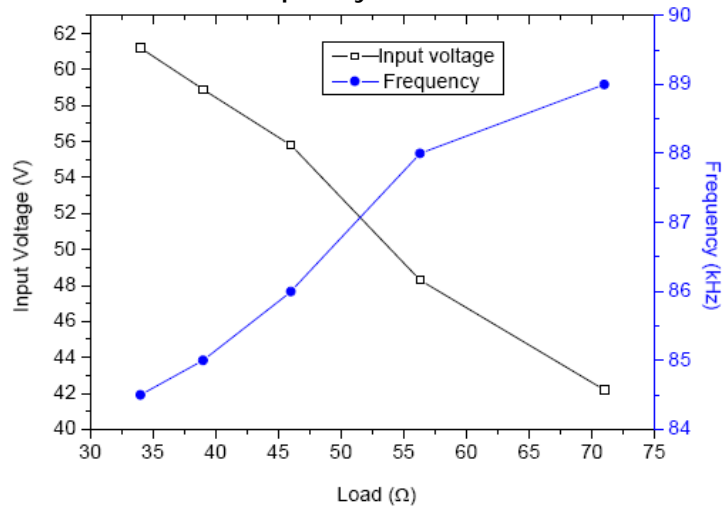

12.4 Temperature Characteristics

Variation of V_{in} , f_{res} with the Temperature

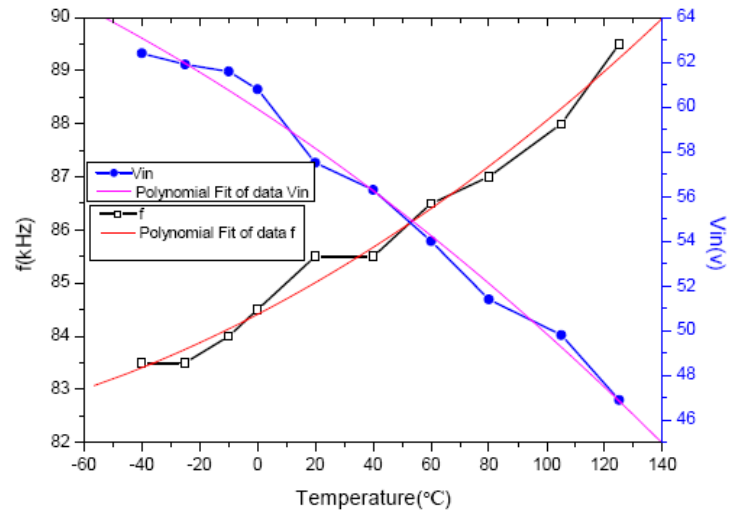

Variation of the input and output capacitances with the Temperature

