

Product Specifications

Product Number: PT A 030 XXX IP

Product Description: 30W Series Step-Down Piezoelectric Transformer

1. Aspect and Dimensions

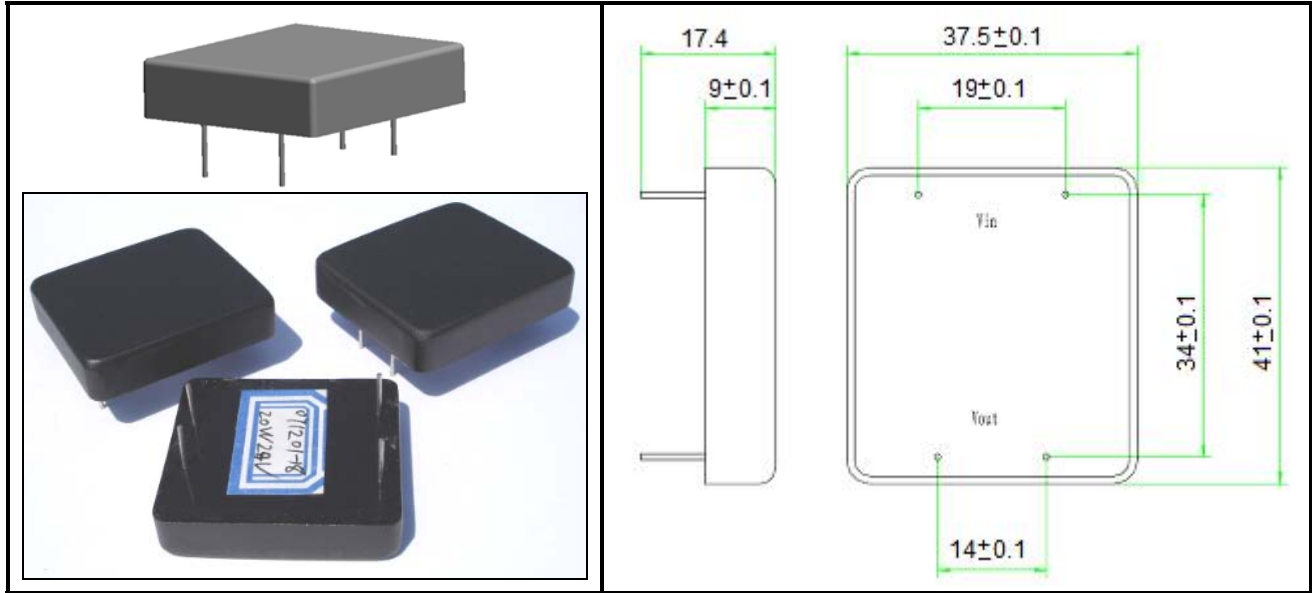

2. Product Number Guide

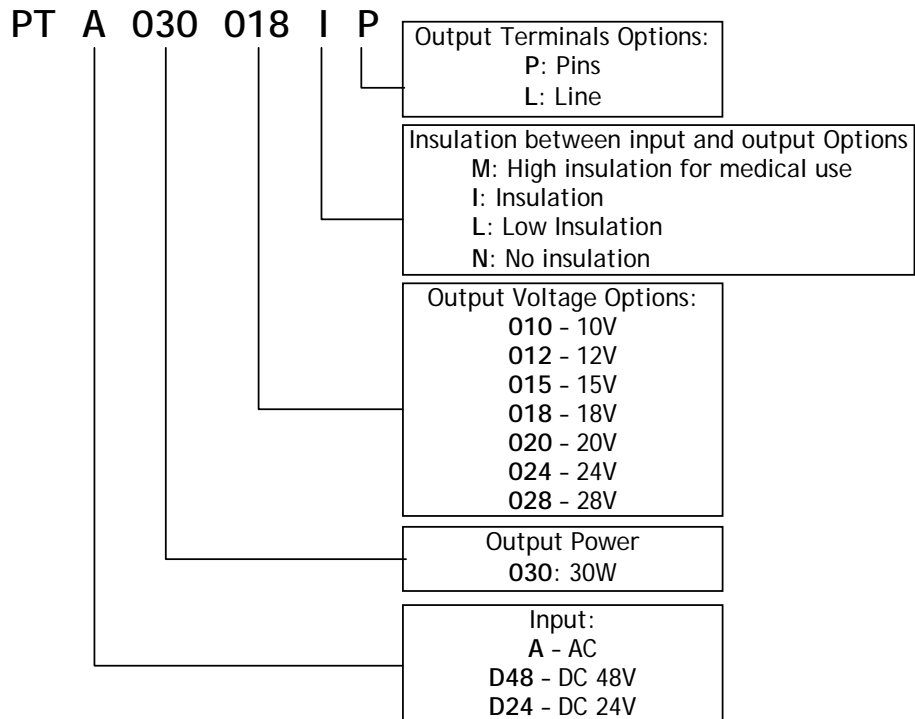



Micromechatronics Inc.

200 Innovation Blvd., Suite 155 ; State College, PA 16803-6602, USA
 Phone: (814) 861-5688 ; Fax: (814) 861-1418. www.mmech.com

3. Selection Table

Table 3.1 Family of Step down PTs.

Output Voltage	Output Power				
	5W	10W	20W	30W (*)	50W
10V	PTA005010IP	PTA010010IP	PTA020010IP	PTA030010IP	PTA050010IP
15V	PTA005015IP	PTA010015IP	PTA020015IP	PTA030015IP	PTA050015IP
18V	PTA005018IP	PTA010018IP	PTA020018IP	PTA030018IP	PTA050018IP
20V			PTA020020IP	PTA030020IP	PTA050020IP
24V	PTA005024IP	PTA010024IP	PTA020024IP	PTA030024IP	PTA050024IP
28V			PTA020028IP	PTA030028IP	PTA050028IP

(*) Highlighted the 30W series covered in this Data Sheet.

4. Electrical Characteristics - 30W Series

Table 4.1 Electrical characteristic

Parameter	Symbol	Specification		Remarks	
Output Power Rating	Pout	30W		Temperature rise is < 20°C	
Operating Temperature Range	T	-55 ~ 125°C		Tested on the PT metal case	
Dielectric Strength between input and output	V	> 3700 Vdc		Current < 20uA	
Output Voltage Rating	Vout	10V	Part No: 030010		
		15V	Part No: 030015		
		18V	Part No: 030018		
		20V	Part No: 030020		
		24V	Part No: 030024		
		28V	Part No: 030028		
Recommended Working Frequency Window	Freq	76 ~ 79 kHz			
Input Voltage Window	Vin	65 ~ 75 V	Part No: 030010	Measured at T _{room}	
		70 ~ 90 V	Part No: 030015		
		75 ~ 90 V	Part No: 030018		
		70 ~ 90 V	Part No: 030020		
		70 ~ 90 V	Part No: 030024		
		70 ~ 85 V	Part No: 030028		
Input Static Capacitance	Cin	16 pF ± 10%	Part No: 030010	Measured at T _{room}	
			Part No: 030015		
			Part No: 030018		
			Part No: 030020		
			Part No: 030024		
			Part No: 030028		
Output Static Capacitance	Cout	530 nF ± 10%	Part No: 030010	Measured at T _{room}	
			235 nF ± 10%		Part No: 030015
			170 nF ± 10%		Part No: 030018
			150 nF ± 10%		Part No: 030020
			93 nF ± 10%		Part No: 030024
			68 nF ± 10%		Part No: 030028

5. Test Circuits

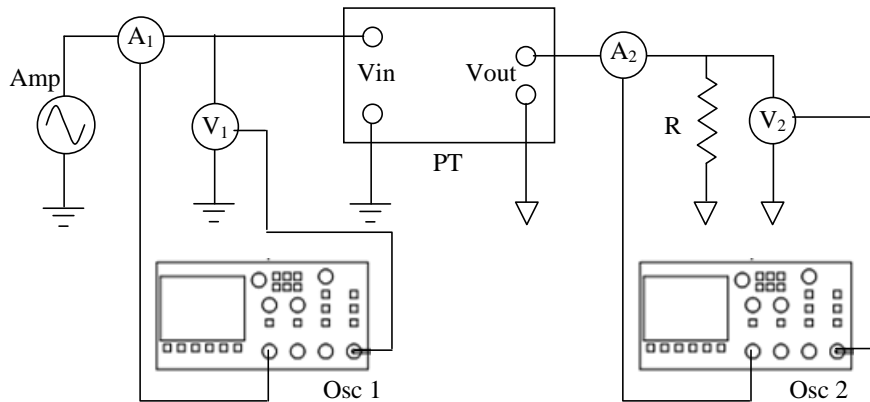

Fig. 5.1 Test circuit

Amp	Amplifier	NF HSA4052
Osc 1	Oscilloscope	Tektronix TDS754D
Osc 2	Oscilloscope	Tektronix TDS754D
A ₁	Current Probe Input Current	Tektronix TCP202
V ₁	Voltage Probe Input Voltage	Tektronix P5100
A ₂	Current Probe Input Current	Tektronix TCP202
V ₂	Voltage Probe Input Voltage	Tektronix P5100
R	Load Resistor	

6. Handling Precautions

6.1 High Voltage

The voltage gain (V_{out}/V_{in}) of a piezoelectric transformer (PT) naturally increases when the output load tends to open circuit. As such, operating a piezoelectric transformer with the output terminals open circuited may lead to higher voltages than those nominally rated. Such a high voltage may damage the transformer and, in some cases, be dangerous to the user. Consequently, when measuring or using the PT under open circuit conditions, user is advised to keep the input voltage as low as possible to avoid any damage. When designing a circuit, an open circuit protection should be considered.

6.2 Storage and transport

- a. Avoid placing the unit under dusty environments or under gas corrosive atmospheres.
- b. Keep the product in a packing material during the delivery. The product should not gain a load (weight) when you take it from the package or when you pile it up.

7. Characteristics of the PTA030010IP (Pout=30W and Vout=10V)

7.1 Response under load conditions (Nominal load: RL=3.3 Ω)

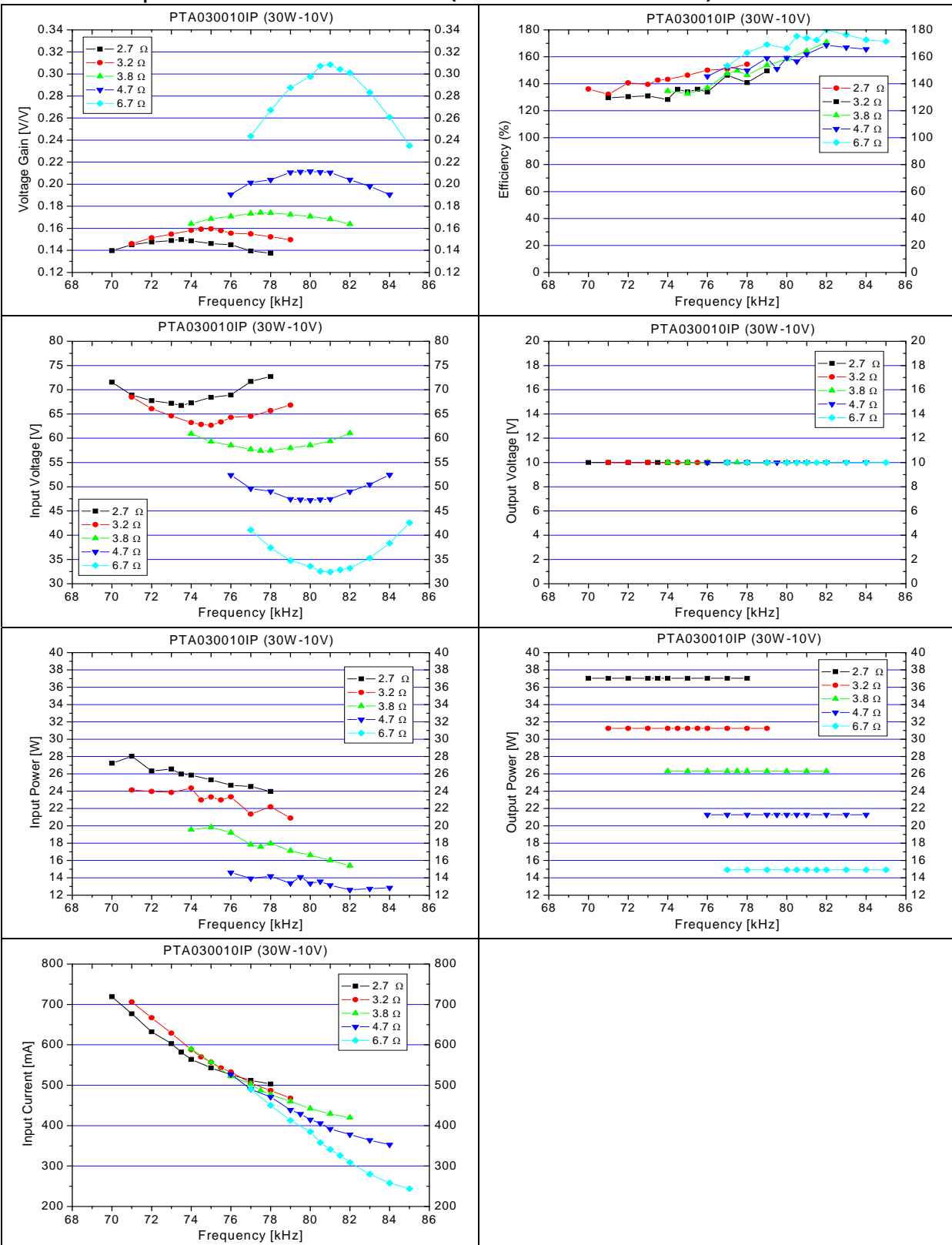

7.2 Voltage Gain under Open Circuit Conditions

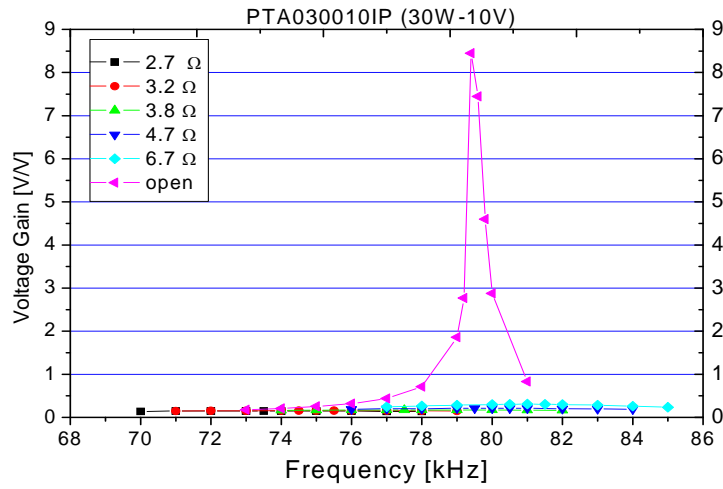

7.3 Variation of resonance frequency with the load

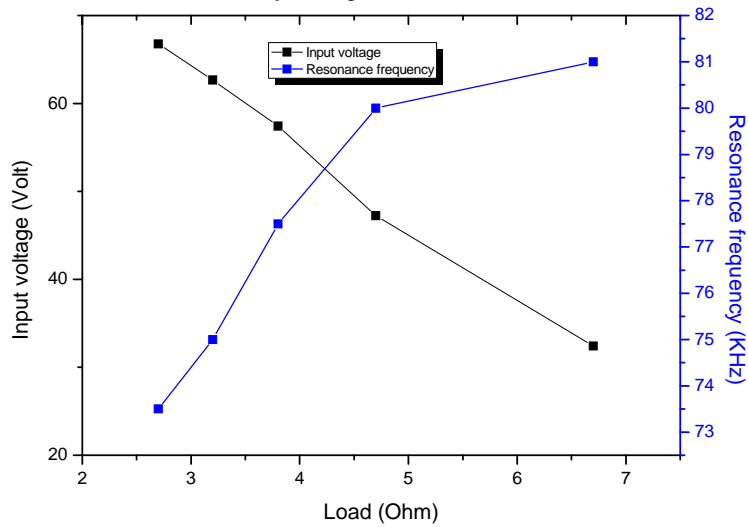

7.4 Temperature Characteristics

Variation of Vin, fres with the Temperature

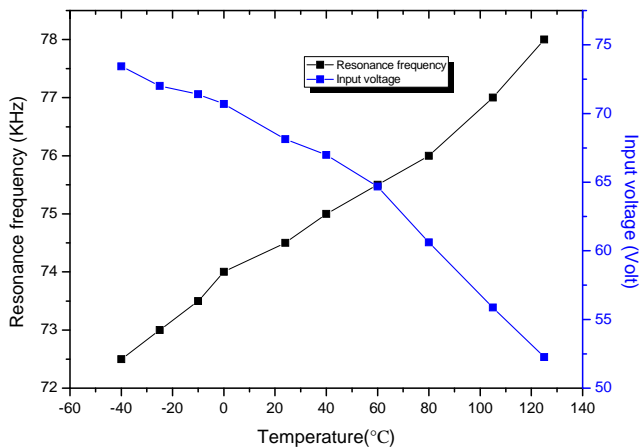

Variation of the input and output capacitances with the Temperature

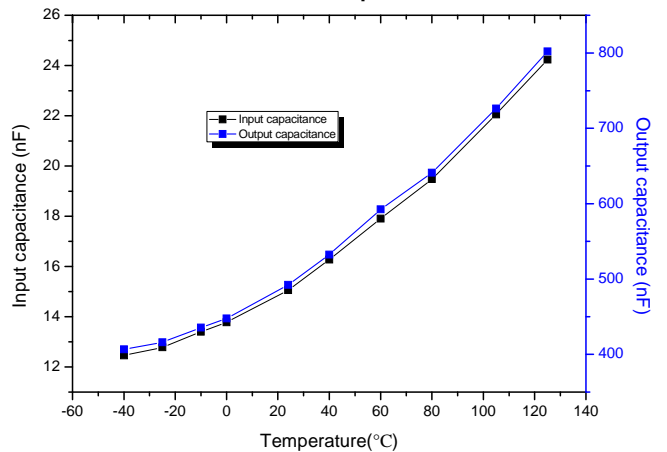

8. Characteristics of the PTA030015IP (Pout=30W and Vout=15V)

8.1 Response under load conditions (Nominal load: $R_L=7.6 \Omega$)

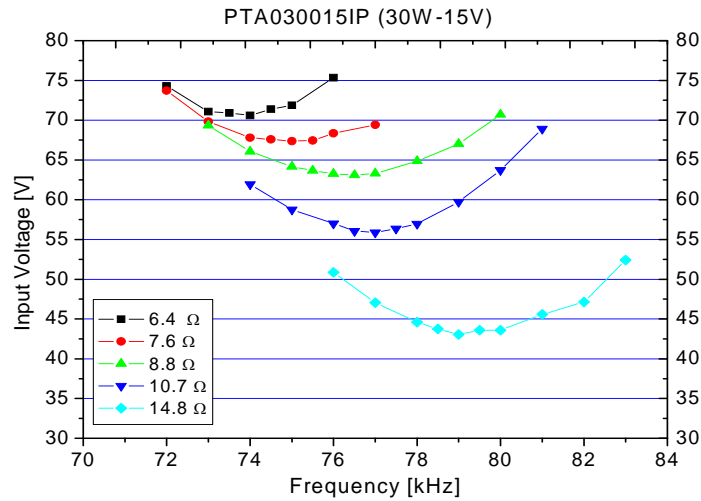
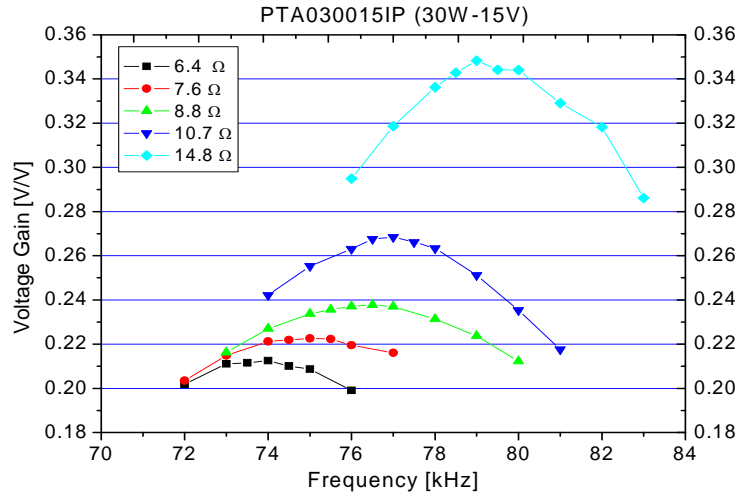

8.2 Voltage Gain under Open Circuit Conditions

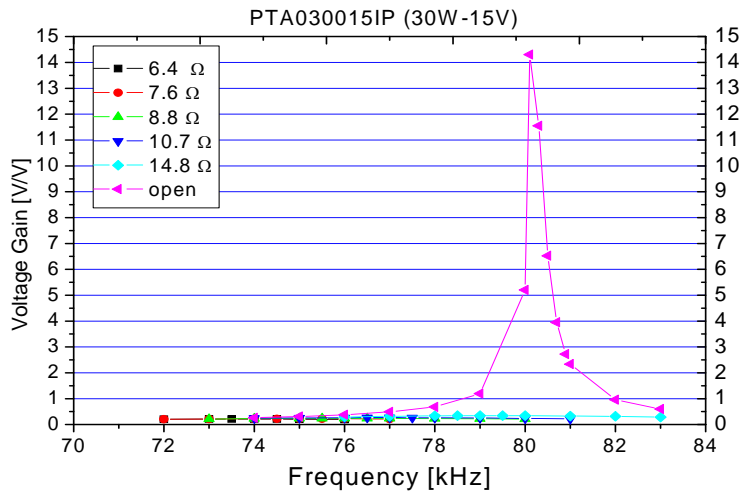

8.3 Variation of resonance frequency with the load

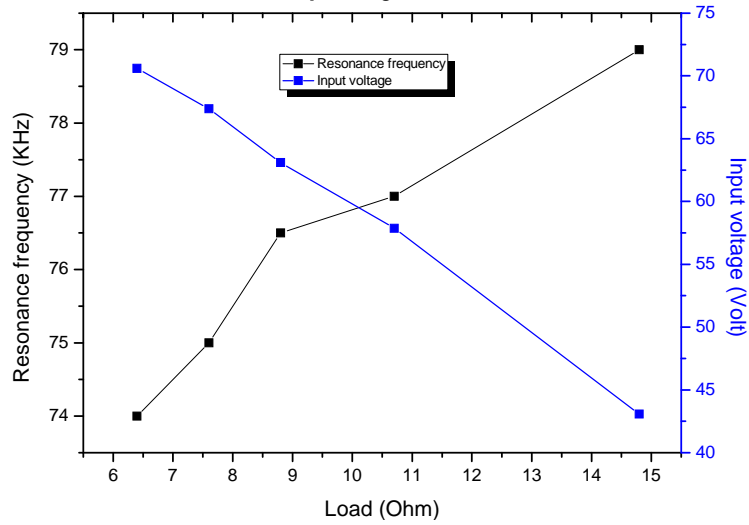

8.4 Variation of Vin, fres with the Temperature

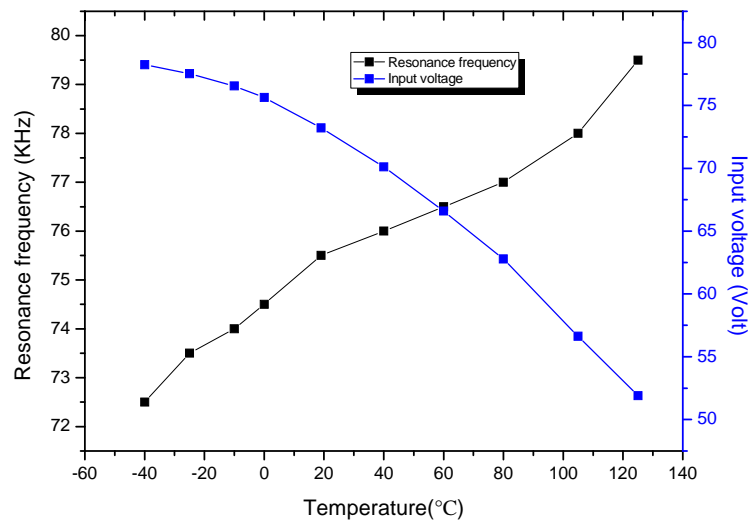

8.5 Variation of the input and output capacitances with the Temperature

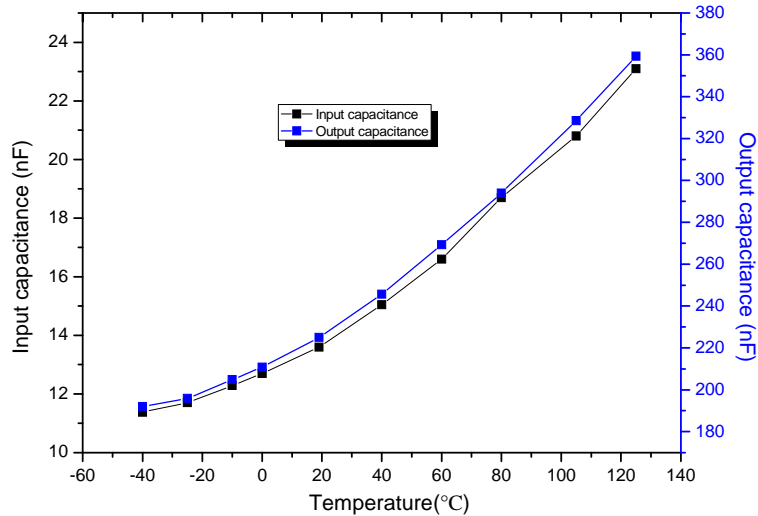

9. Characteristics of the PTA030018IP (Pout=30W and Vout=18V)

9.1 Response under load conditions (Nominal load: $R_L=10.7\ \Omega$)

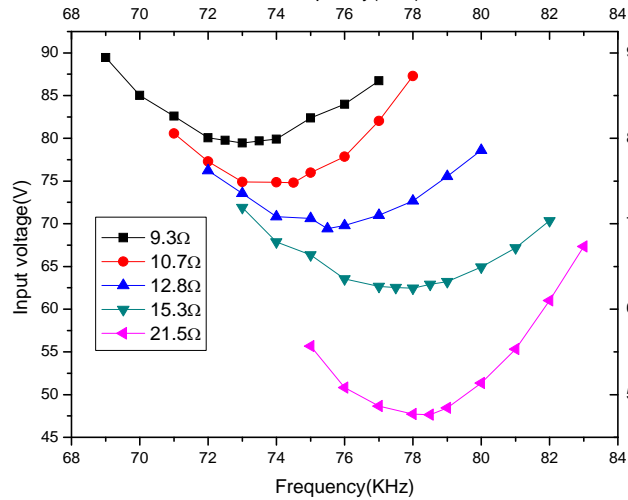
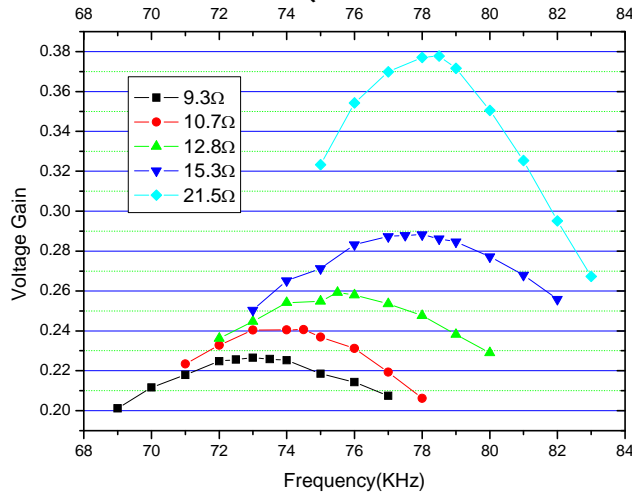

9.2 Voltage Gain under Open Circuit Conditions

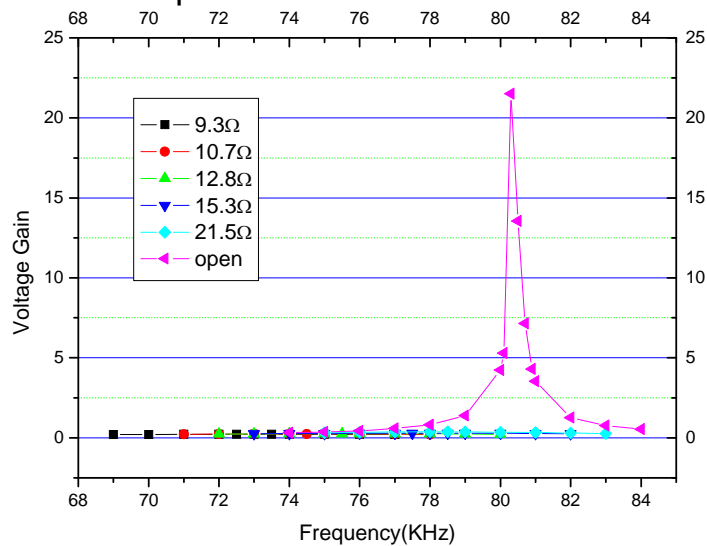

9.3 Variation of resonance frequency with the load

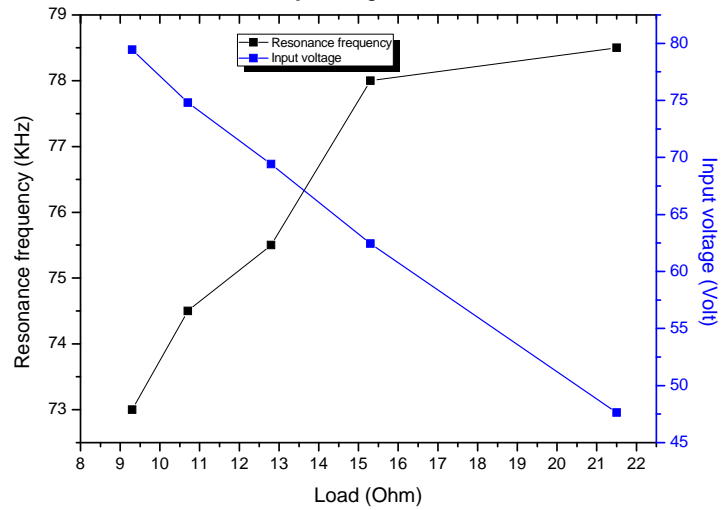

9.4 Variation of V_{in} , f_{res} with the Temperature

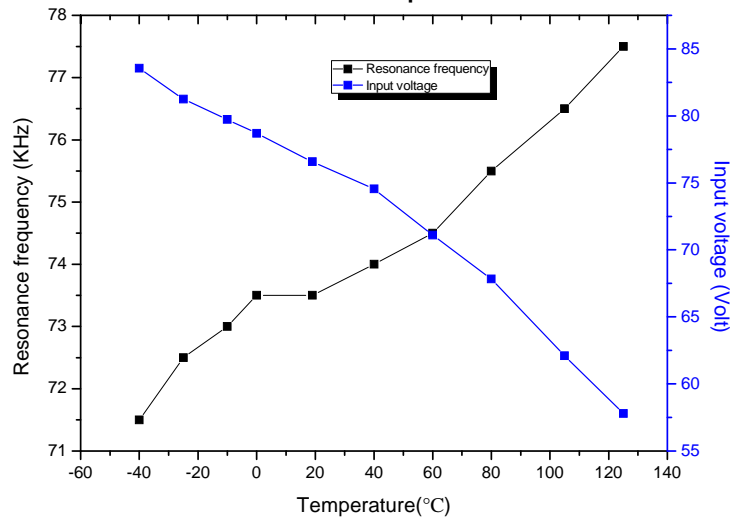

9.5 Variation of the input and output capacitances with the Temperature

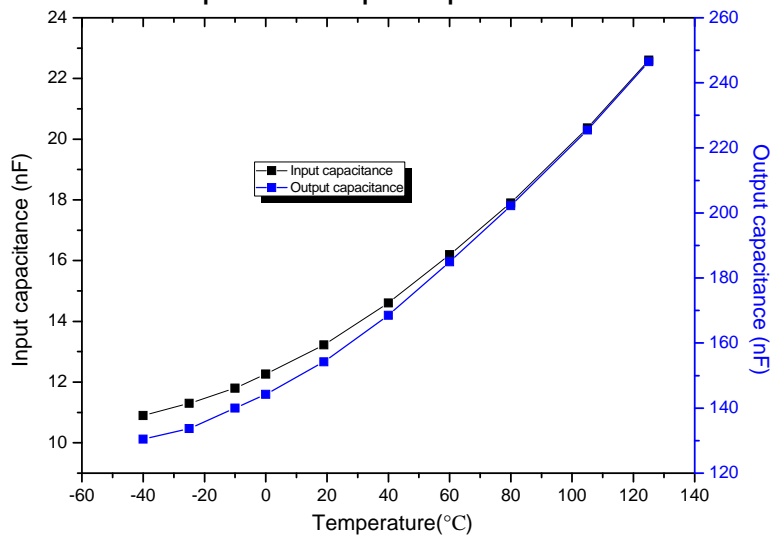

10. Characteristics of the PTA030020IP (Pout=30W and Vout=20V)

10.1 Response under load conditions (Nominal load: $R_L=13.4 \Omega$)

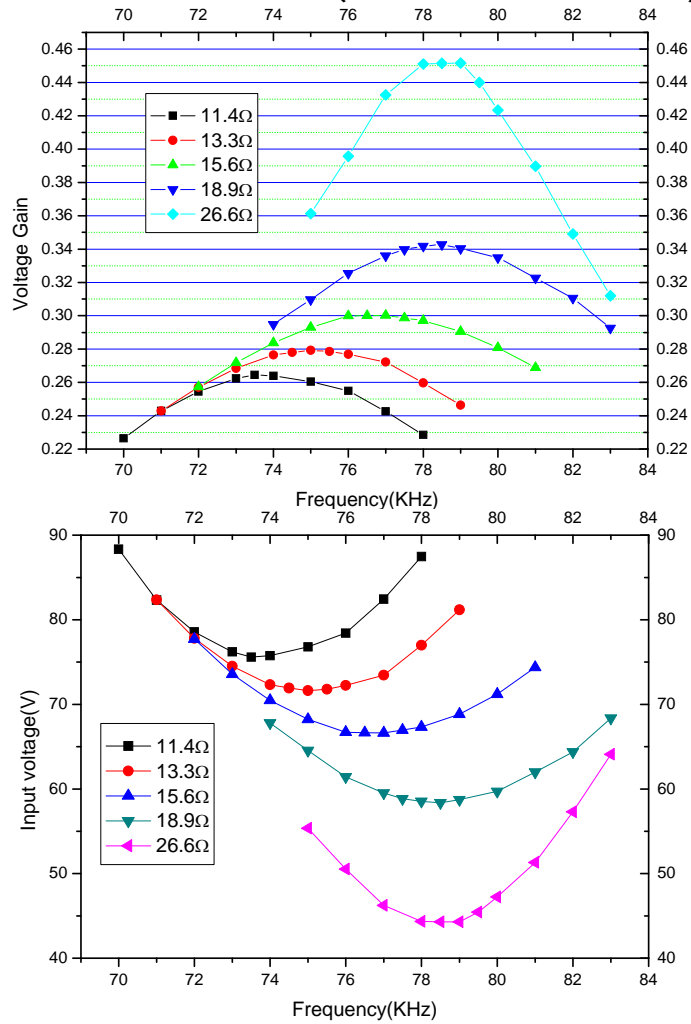

10.2 Voltage Gain under Open Circuit Conditions

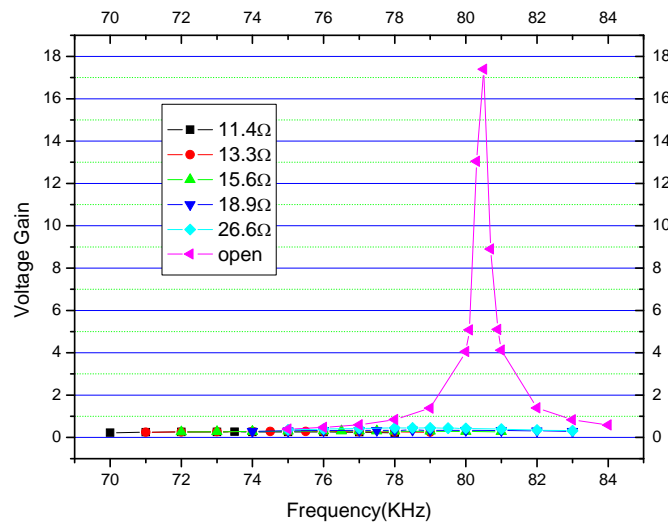

10.3 Variation of resonance frequency with the load

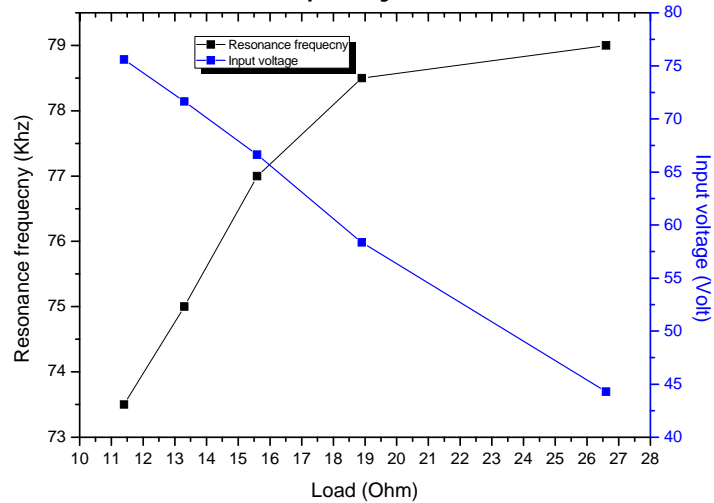

10.4 Variation of Vin, fres with the Temperature

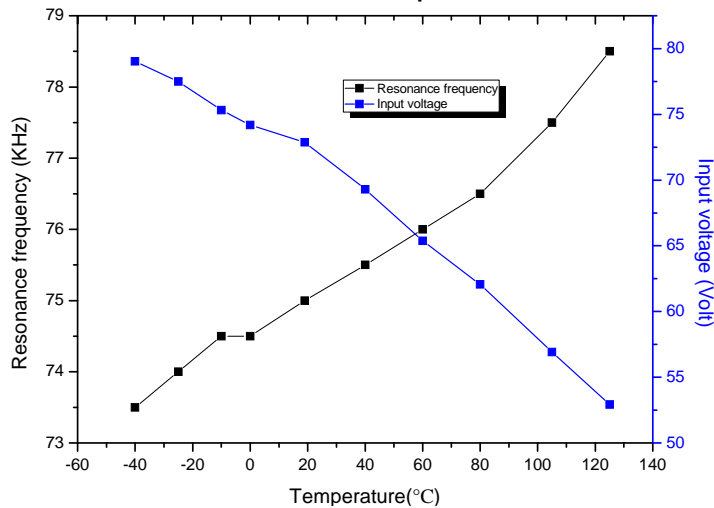

10.5 Variation of the input and output capacitances with the Temperature

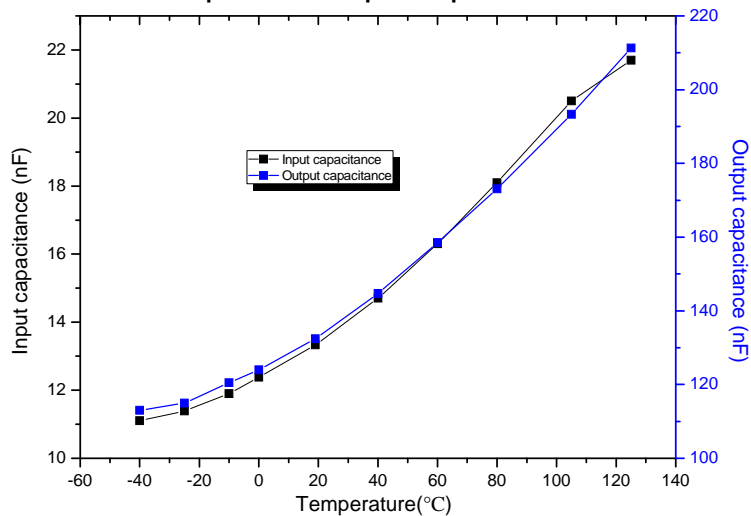

11. Characteristics of the PTA030024IP (Pout=30W and Vout=24V)

11.1 Response under load conditions (Nominal load: RL=19.2 Ω)

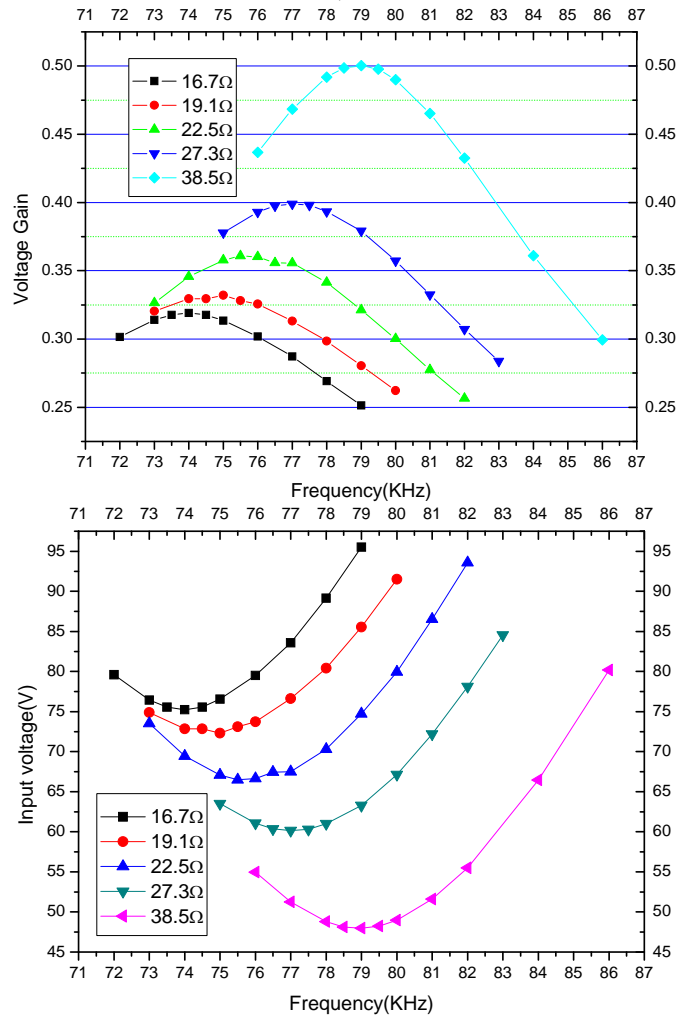

11.2 Voltage Gain under Open Circuit Conditions

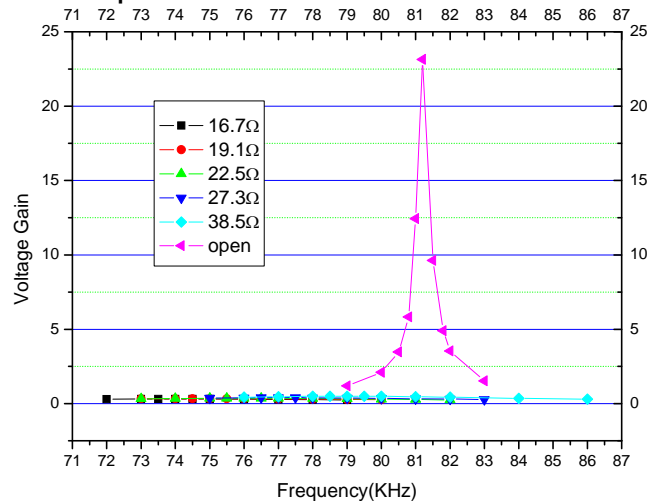

11.3 Variation of resonance frequency with the load

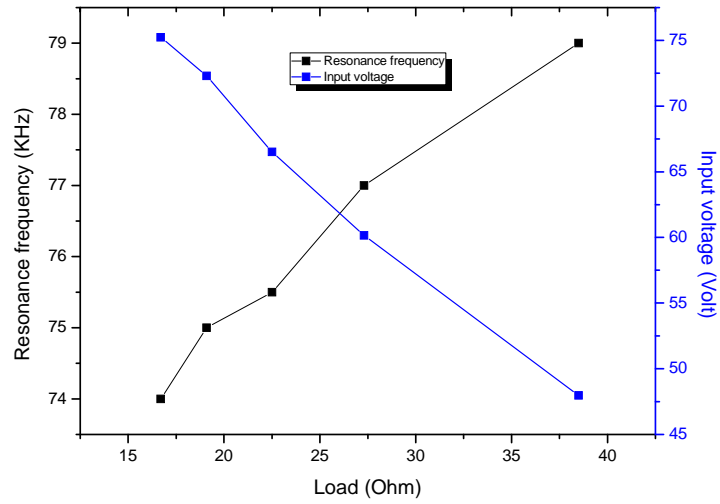

11.4 Variation of Vin, fres with the Temperature

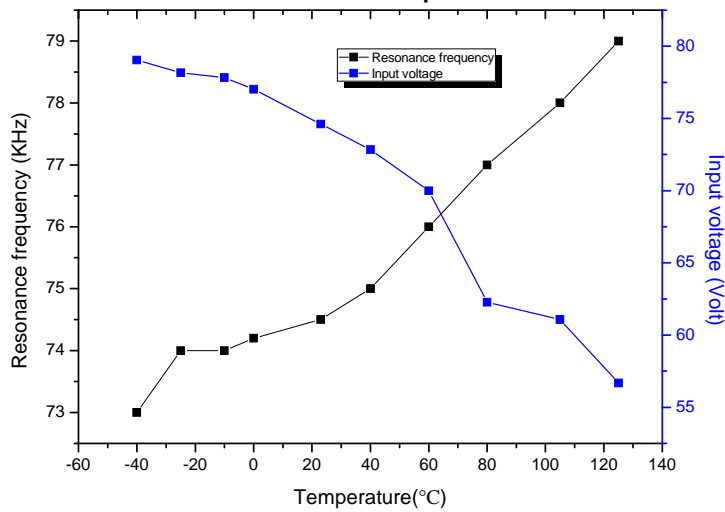

11.5 Variation of the input and output capacitances with the Temperature

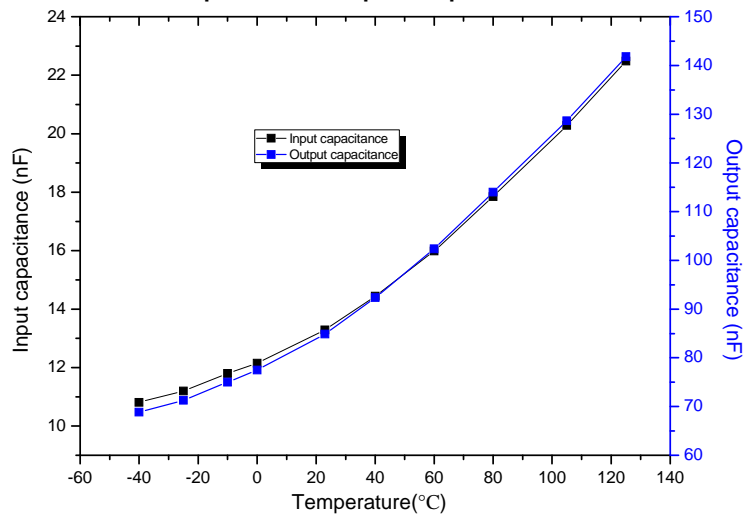

12. Characteristics of the PTA030028IP (Pout=30W and Vout=28V)

12.1 Response under load conditions (Nominal load: RL=26.13 Ω)

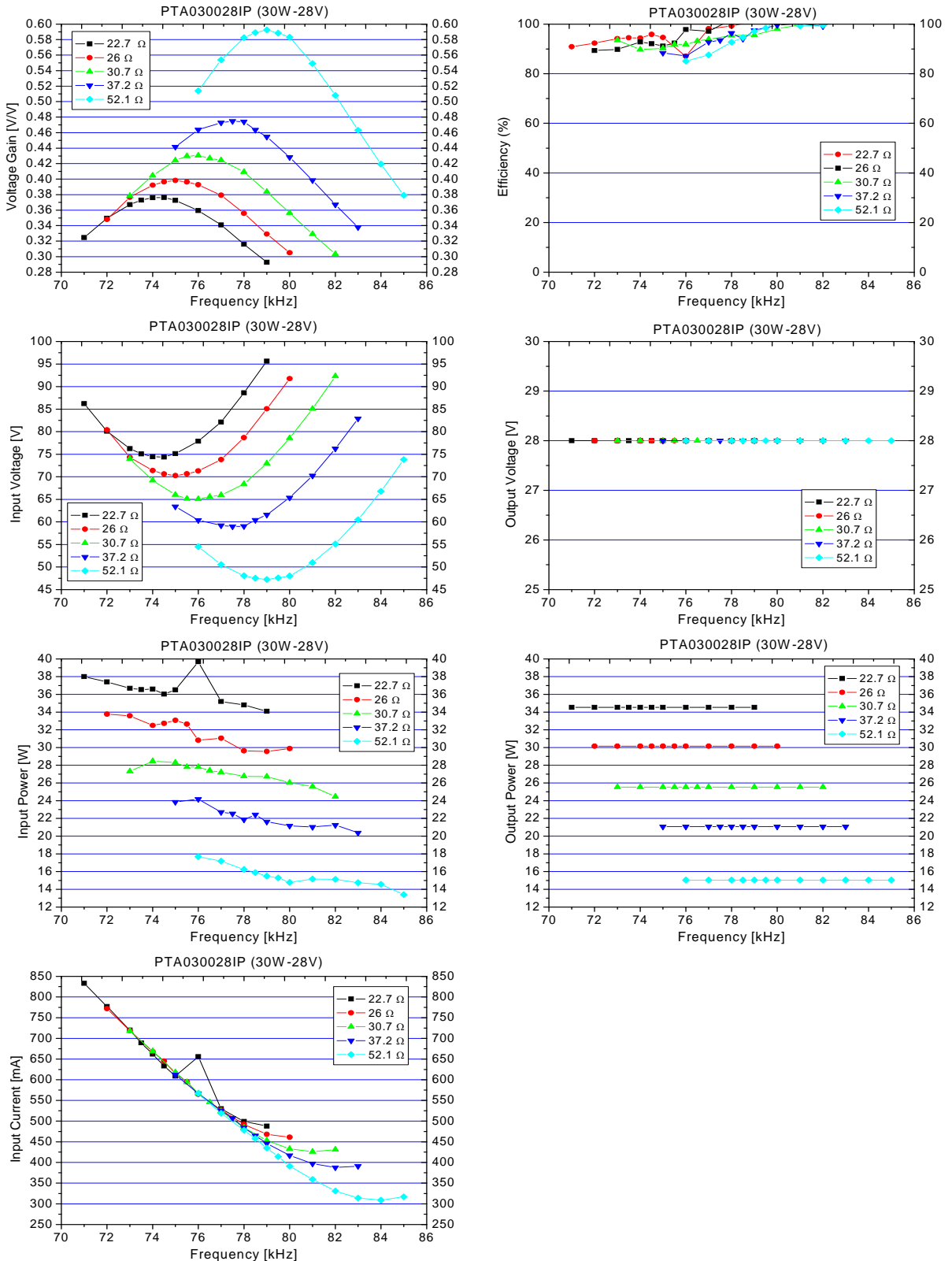

12.2 Voltage Gain under Open Circuit Conditions

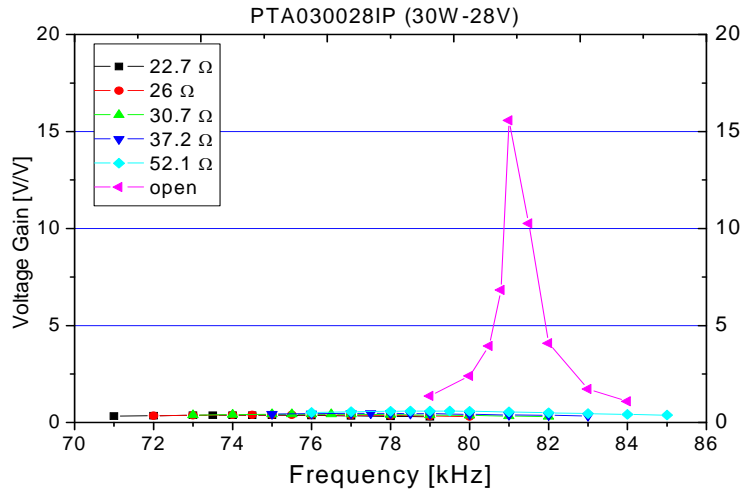

12.3 Variation of resonance frequency with the load

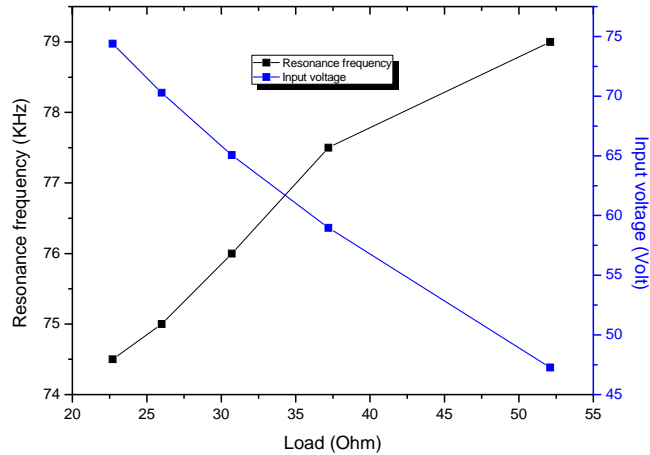

12.4 Temperature Characteristics

Variation of V_{in} , f_{res} with the Temperature

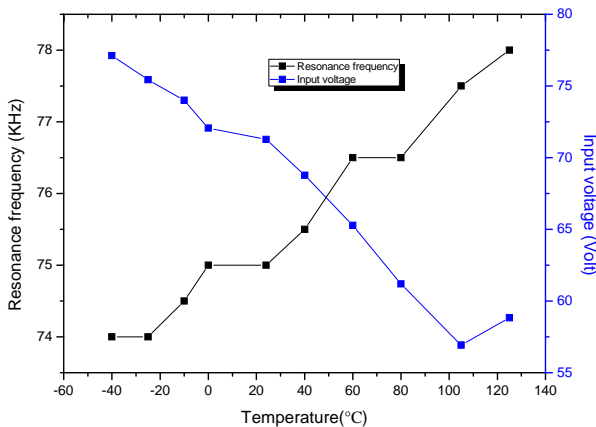

Variation of the input and output capacitances with the Temperature

