

Product Specifications

Product Number: PT A 005 XXX IP

Product Description: 5W Series Step-Down Piezoelectric Transformer

1. Aspect and Dimensions

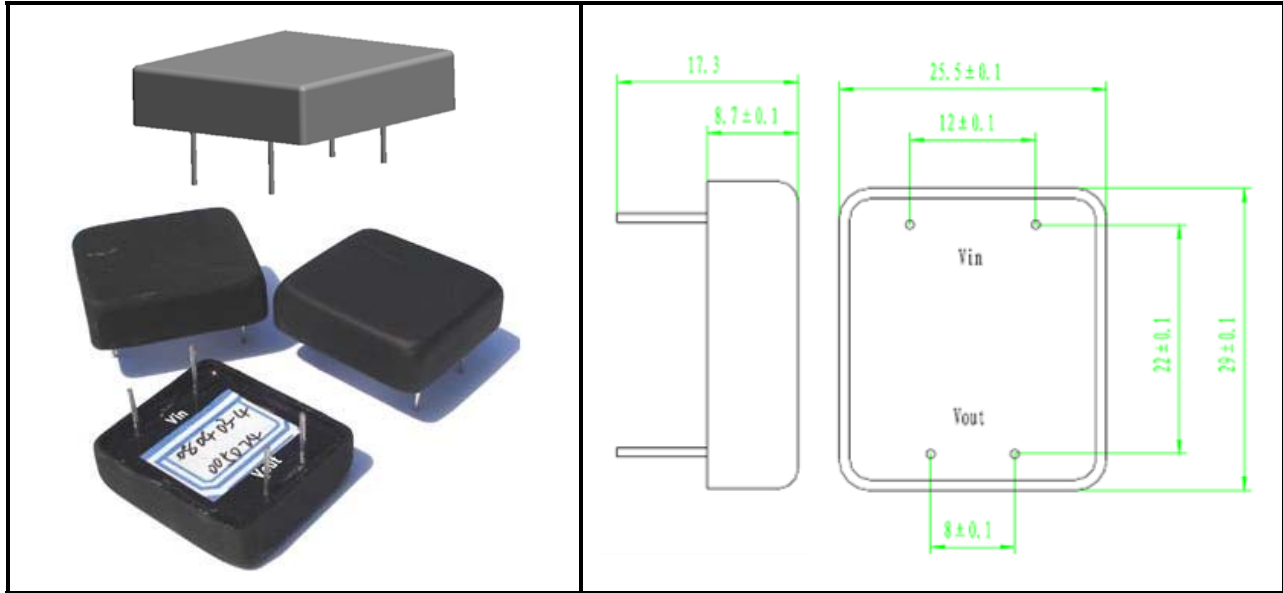

2. Product Number Guide

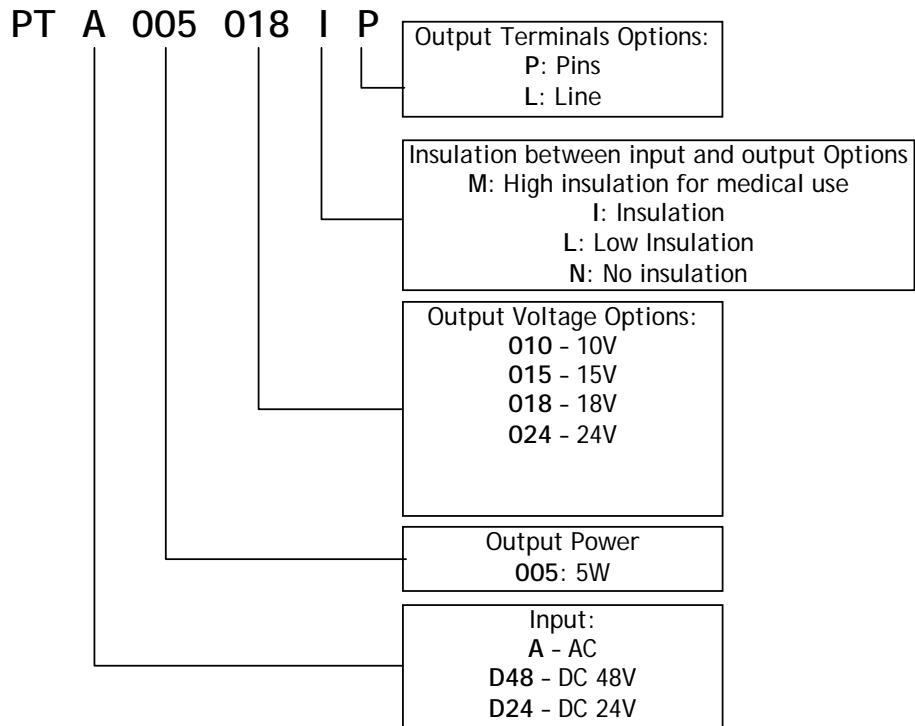



Micromechatronics Inc.

200 Innovation Blvd., Suite 155 ; State College, PA 16803-6602, USA
 Phone: (814) 861-5688 ; Fax: (814) 861-1418. www.mmech.com

3. Selection Table

Table 3.1 Family of Step down PTs.

Output Voltage	Output Power				
	5W	10W	20W	30W	50W
10V	PTA005010IP	PTA010010IP	PTA020010IP	PTA030010IP	PTA050010IP
15V	PTA005015IP	PTA010015IP	PTA020015IP	PTA030015IP	PTA050015IP
18V	PTA005018IP	PTA010018IP	PTA020018IP	PTA030018IP	PTA050018IP
20V			PTA020020IP	PTA030020IP	PTA050020IP
24V	PTA005024IP	PTA010024IP	PTA020024IP	PTA030024IP	PTA050024IP
28V			PTA020028IP	PTA030028IP	PTA050028IP

^(*) Highlighted the 5W series covered in this Data Sheet.

4. Electrical Characteristics - 5W Series

Table 4.1 Electrical characteristic

Parameter	Symbol	Specification		Remarks
Output Power Rating	Pout	5W		Temperature rise is below 20°C
Operating Temperature Range	T	-55 ~ 125°C		Tested on the PT metal case
Dielectric Strength between input and output	V	> 3700 Vdc		Current < 20uA
Output Voltage Rating	Vout	10V	Part No: 005010	
		15V	Part No: 005015	
		18V	Part No: 005018	
		24V	Part No: 005024	
Recommended Working Frequency Window	Freq	121 ~ 134 kHz		
Input Voltage Window	Vin	28 ~ 50 V	Part No: 005010	Measured at T _{room}
		28 ~ 45 V	Part No: 005015	
		24 ~ 45 V	Part No: 005018	
		20 ~ 45 V	Part No: 005024	
Input Static Capacitance	Cin	4 nF ± 10%	Part No: 005010	Measured at T _{room}
			Part No: 005015	
			Part No: 005018	
			Part No: 005024	
Output Static Capacitance	Cout	47.5 nF ± 10%	Part No: 005010	Measured at T _{room}
		17 nF ± 10%	Part No: 005015	
		12 nF ± 10%	Part No: 005018	
		7.5 nF ± 10%	Part No: 005024	

5. Test Circuits

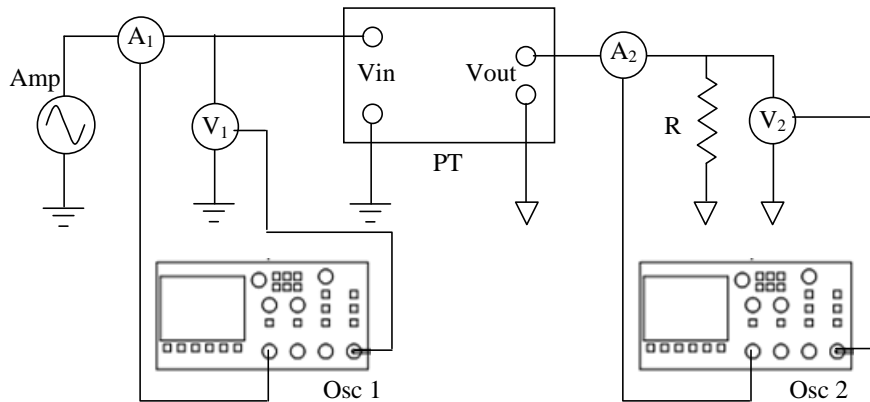

Fig. 5.1 Test circuit

Amp	Amplifier	NF HSA4052
Osc 1	Oscilloscope	Tektronix TDS754D
Osc 2	Oscilloscope	Tektronix TDS754D
A ₁	Current Probe Input Current	Tektronix TCP202
V ₁	Voltage Probe Input Voltage	Tektronix P5100
A ₂	Current Probe Input Current	Tektronix TCP202
V ₂	Voltage Probe Input Voltage	Tektronix P5100
R	Load Resistor	

6. Handling Precautions

6.1 High Voltage

The voltage gain (V_{out}/V_{in}) of a piezoelectric transformer (PT) naturally increases when the output load tends to open circuit. As such, operating a piezoelectric transformer with the output terminals open circuited may lead to higher voltages than those nominally rated. Such a high voltage may damage the transformer and, in some cases, be dangerous to the user. Consequently, when measuring or using the PT under open circuit conditions, user is advised to keep the input voltage as low as possible to avoid any damage. When designing a circuit, an open circuit protection should be considered.

6.2 Storage and transport

- a. Avoid placing the unit under dusty environments or under gas corrosive atmospheres.
- b. Keep the product in a packing material during the delivery. The product should not gain a load (weight) when you take it from the package or when you pile it up.

7. Characteristics of the PTA005010IP (Pout=5W and Vout=10V)

7.1 Response under load conditions (Nominal load: RL=20 Ω)

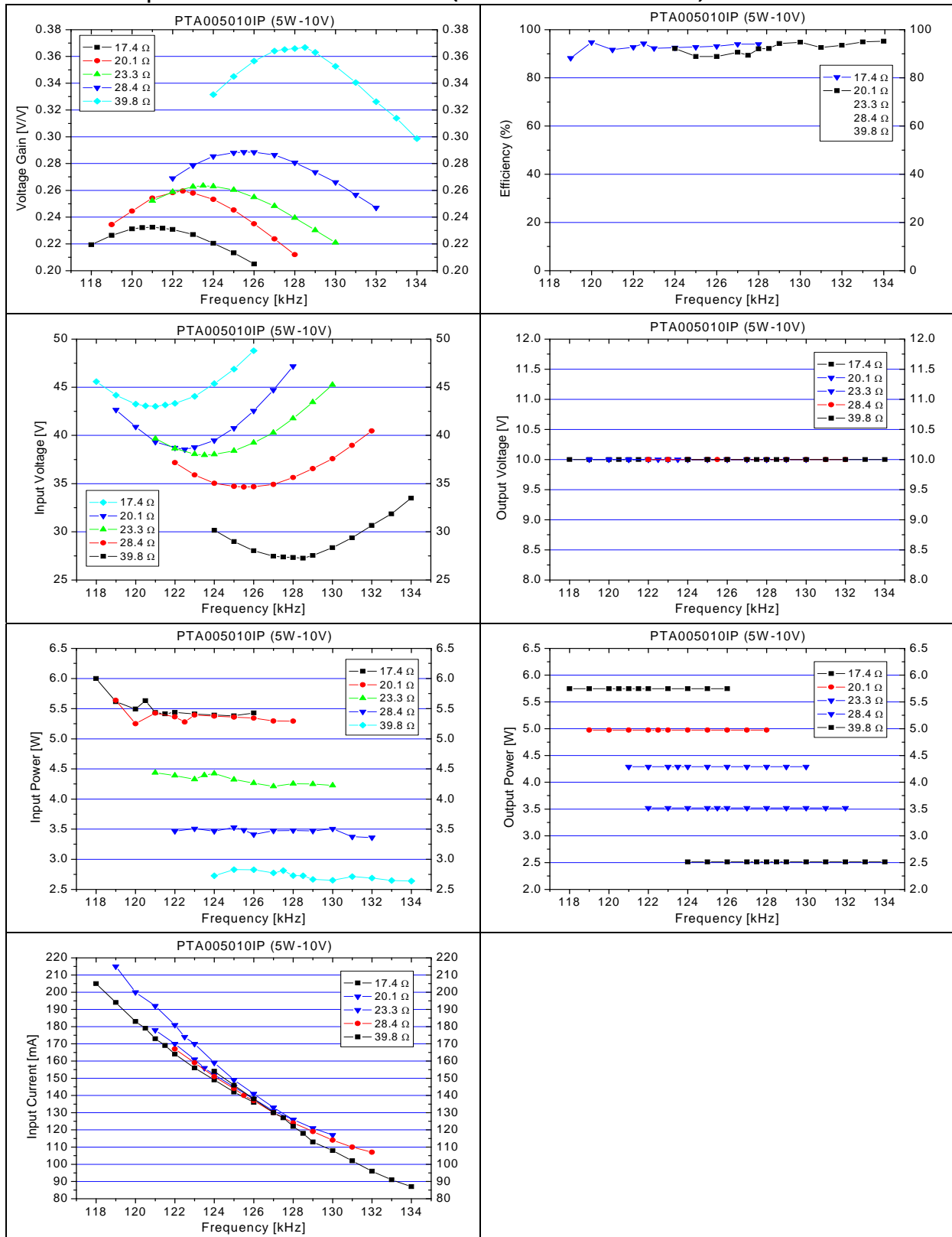

7.2 Voltage Gain under Open Circuit Conditions

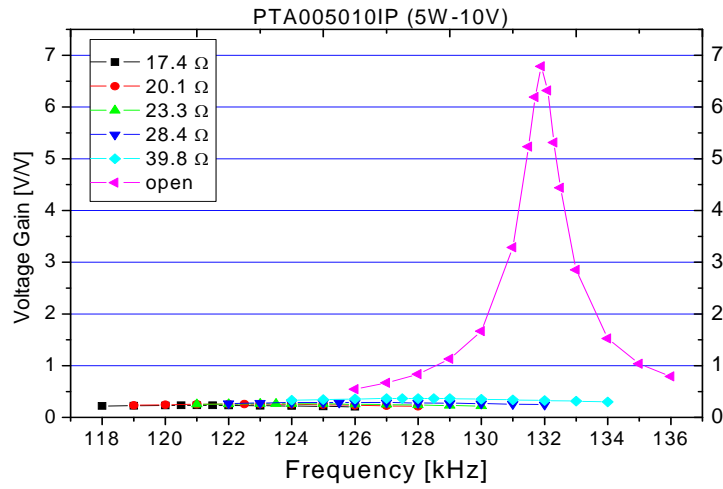

7.3 Variation of resonance frequency and input voltage at resonance with the load

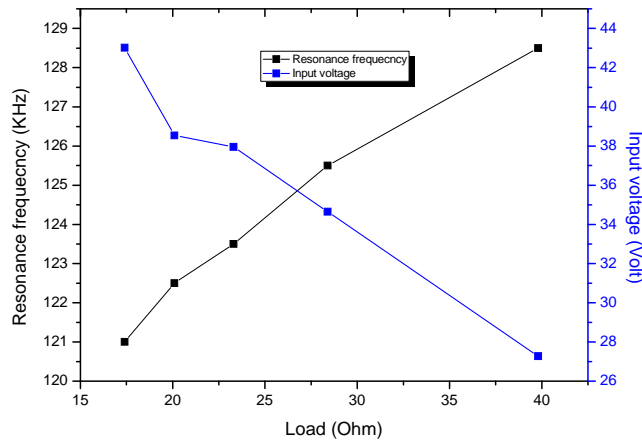

7.4 Temperature Characteristics

Variation of V_{in} , f_{res} with the Temperature

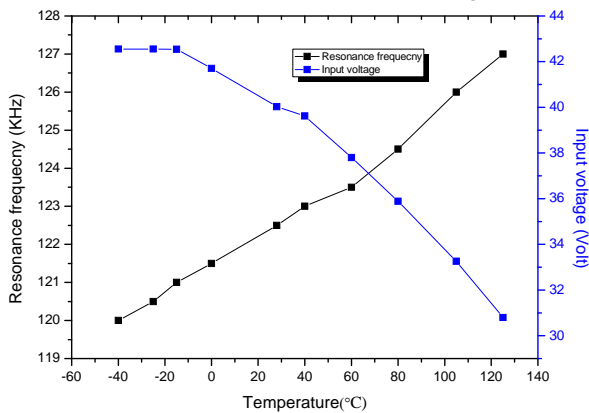

Variation of the input and output capacitances with the Temperature

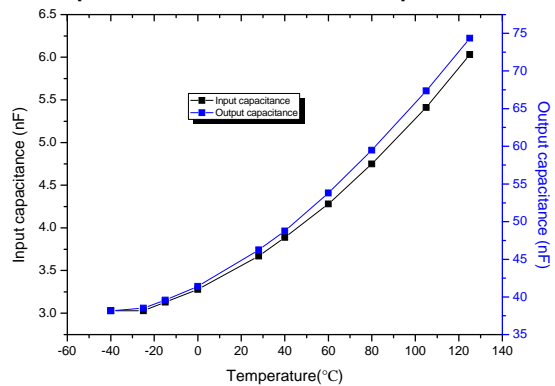

8. Characteristics of the PTA005015IP (Pout=5W and Vout=15V)

8.1 Response under load conditions (Nominal load: RL=45 Ω)

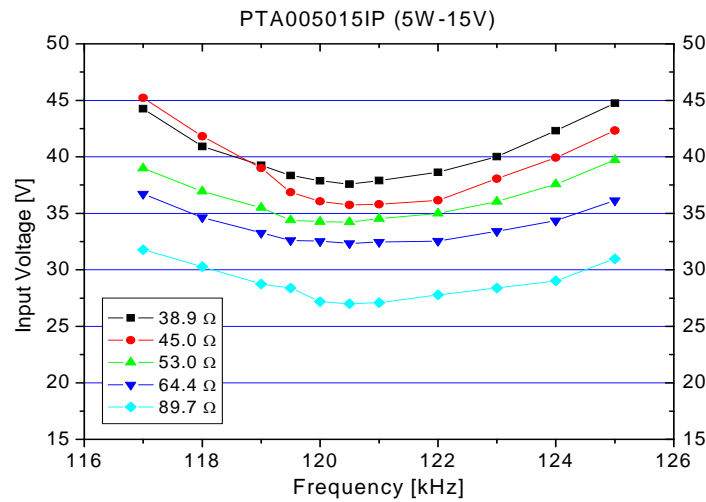
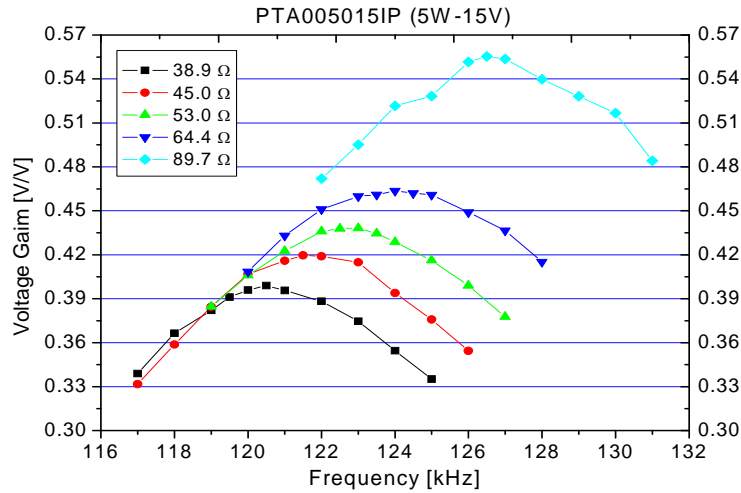

8.2 Voltage Gain under Open Circuit Conditions

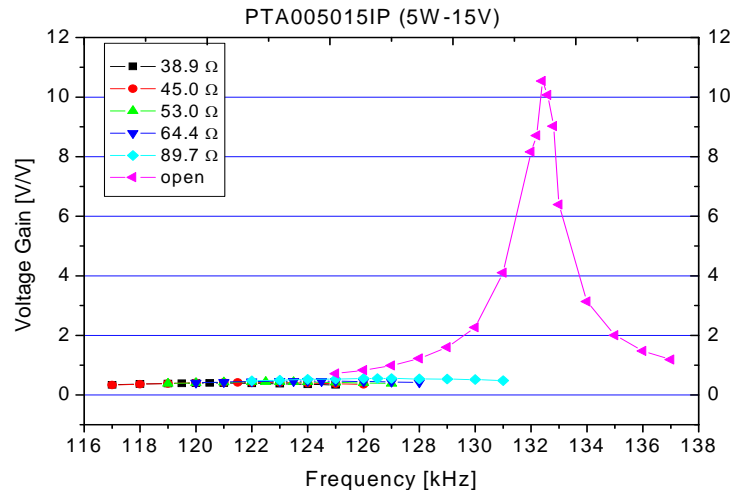

8.3 Variation of resonance frequency with the load

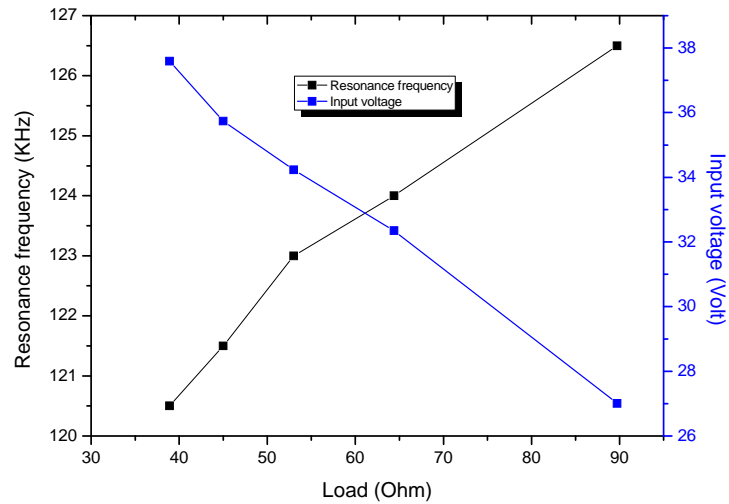

8.4 Variation of Vin, fres with the Temperature

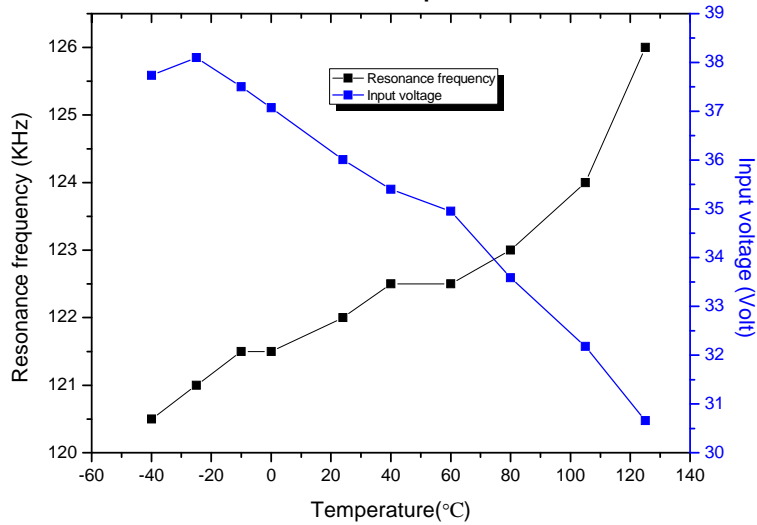

8.5 Variation of the input and output capacitances with the Temperature

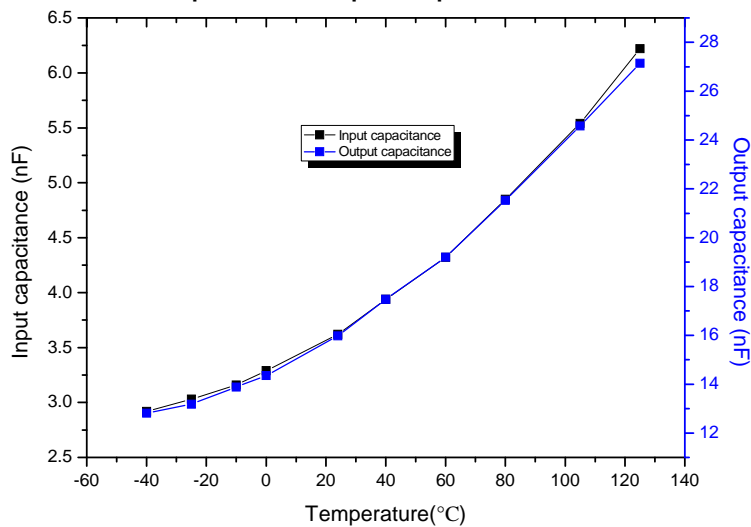

9. Characteristics of the PTA005015IP (Pout=5W and Vout=18V)

9.1 Response under load conditions (Nominal load: $R_L=64.8 \Omega$)

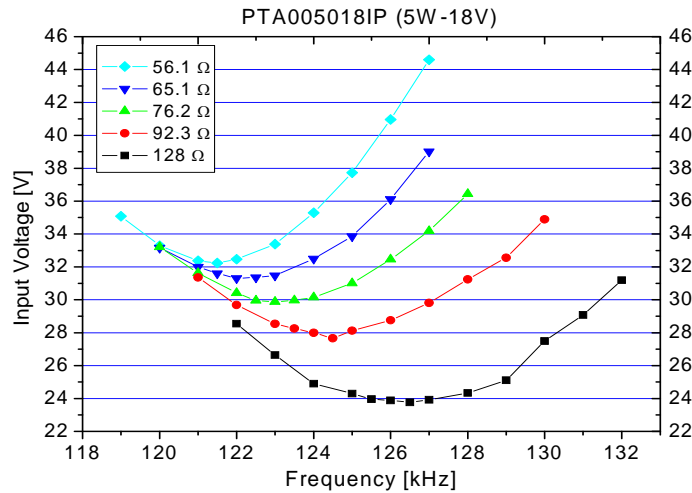
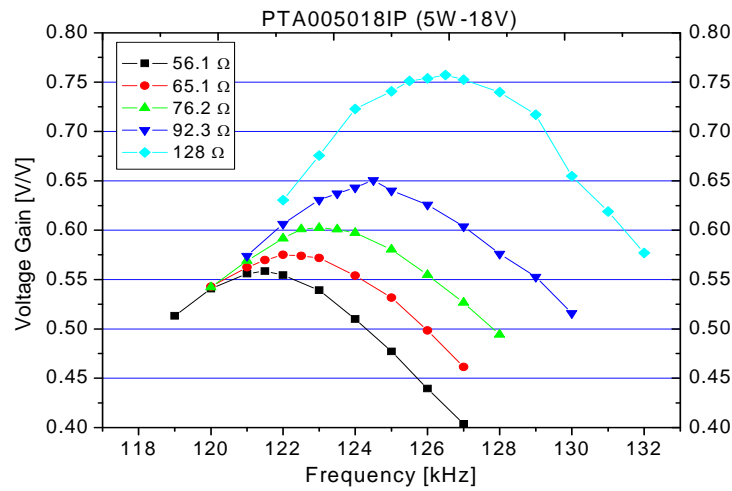

9.2 Voltage Gain under Open Circuit Conditions

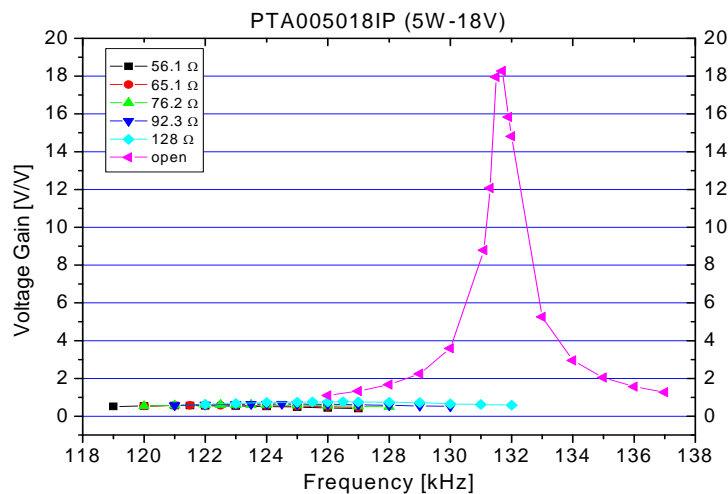

9.3 Variation of resonance frequency with the load

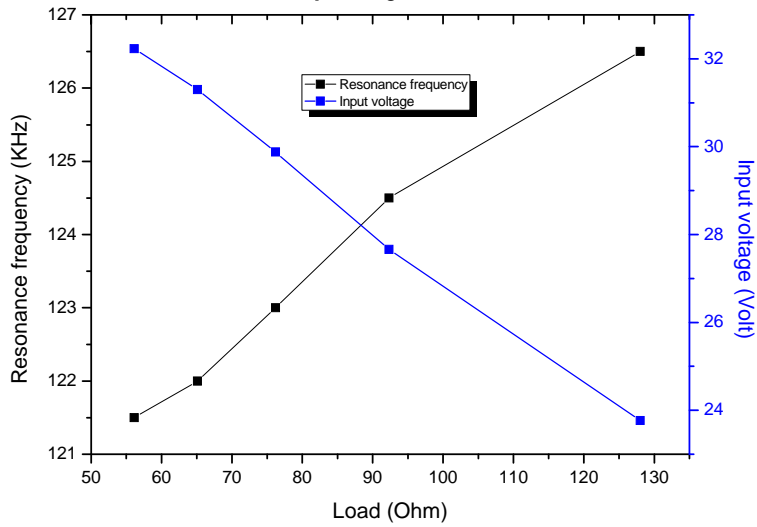

9.4 Variation of V_{in} , f_{res} with the Temperature

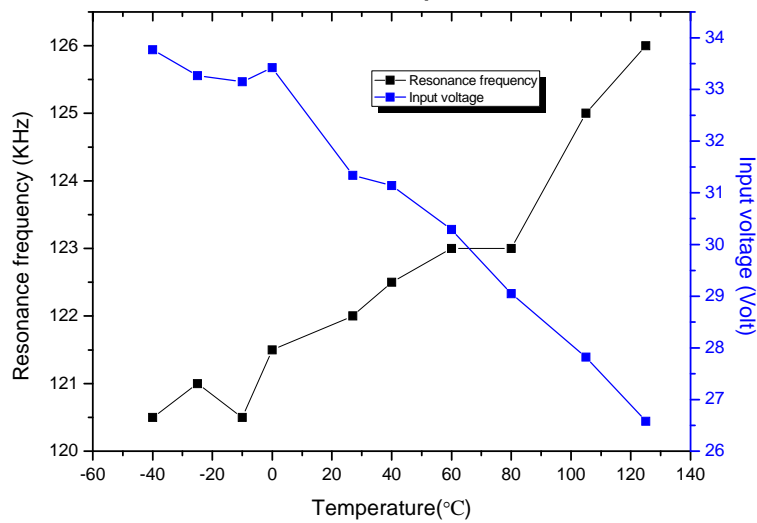

9.5 Variation of the input and output capacitances with the Temperature

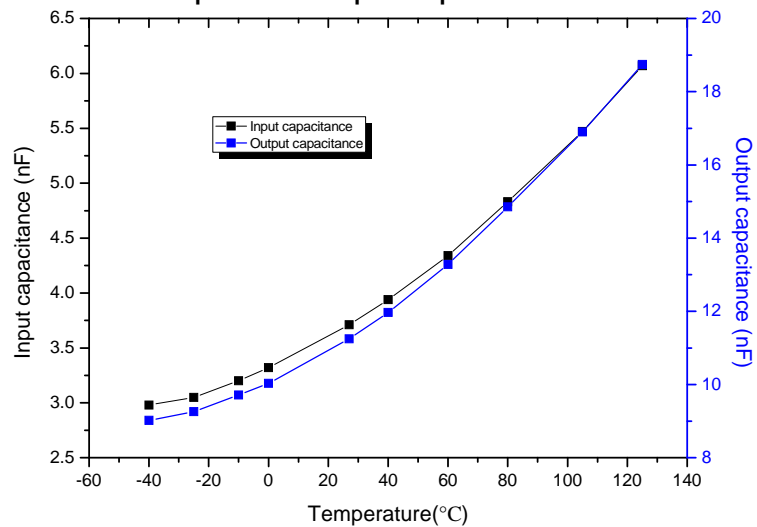

10. Characteristics of the PTA005024IP (Pout=5W and Vout=24V)

10.1 Response under load conditions (Nominal load: RL=115.2 Ω)

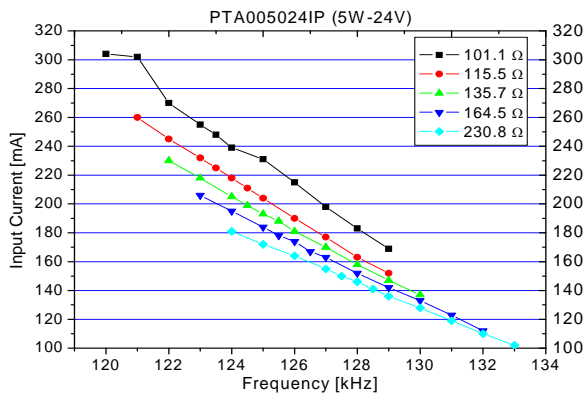
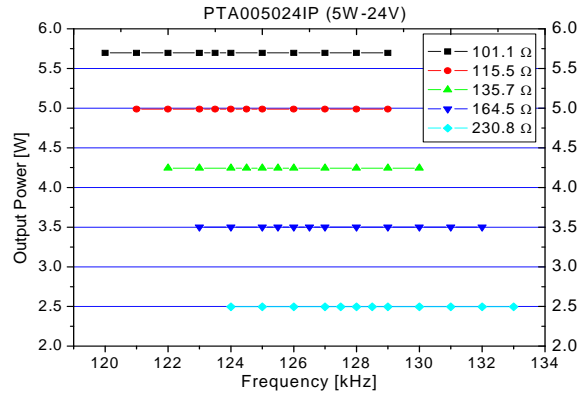
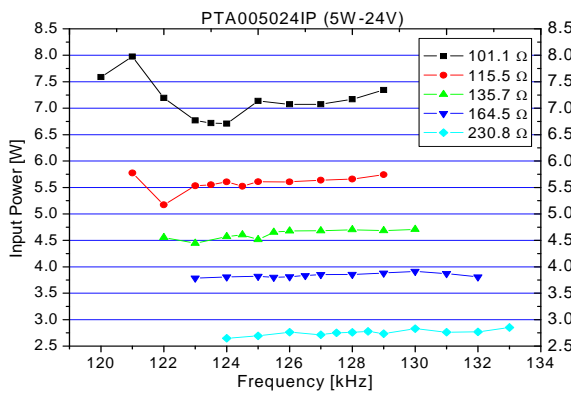
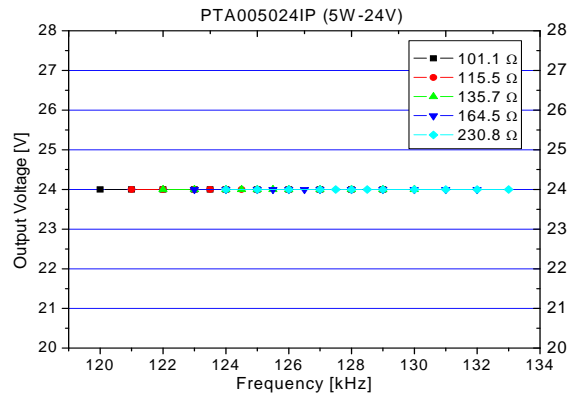
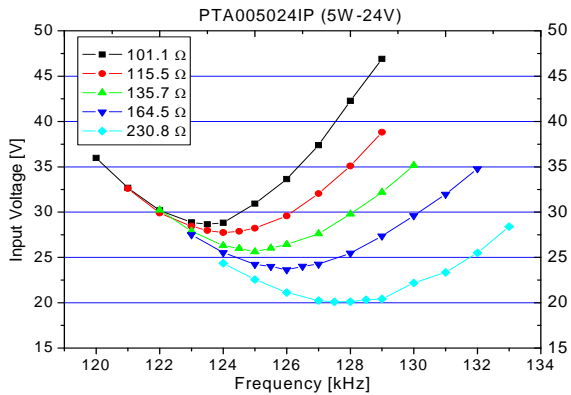
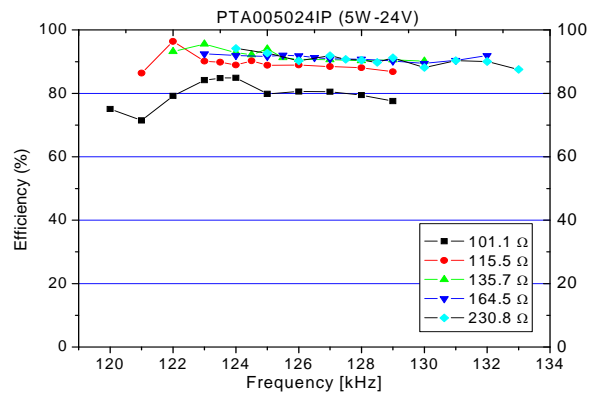
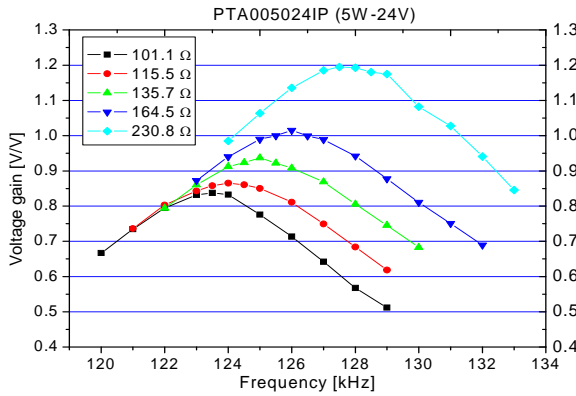

10.2 Voltage Gain under Open Circuit Conditions

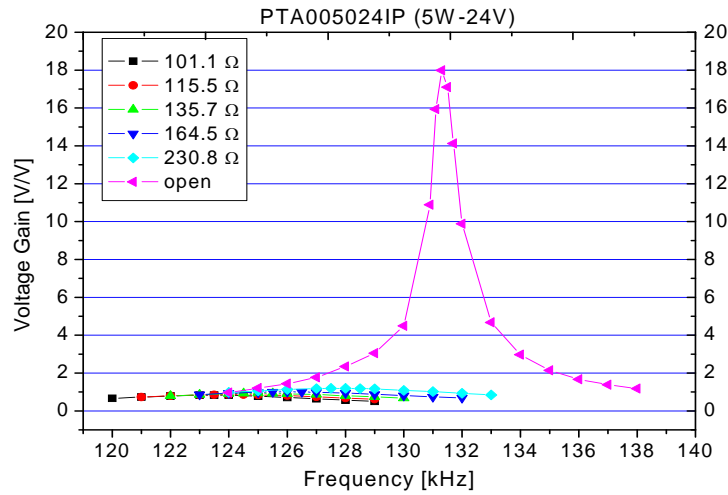

10.3 Variation of resonance frequency with the load

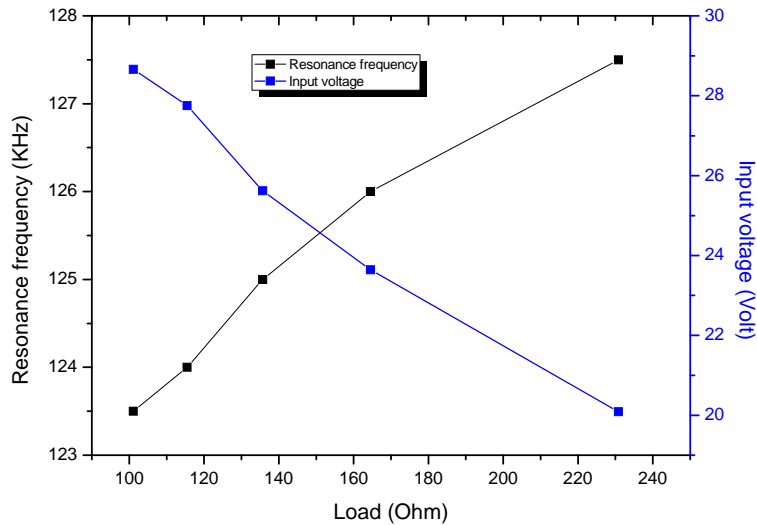

10.4 Temperature Characteristics

Variation of V_{in} , f_{res} with the Temperature

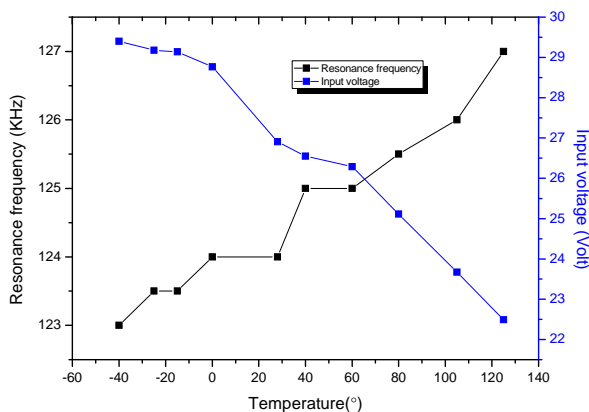

Variation of the input and output capacitances with the Temperature

