

ULTRASONIC MOTOR

USR30-V
(VACUUM TYPE)

DIMENSIONS

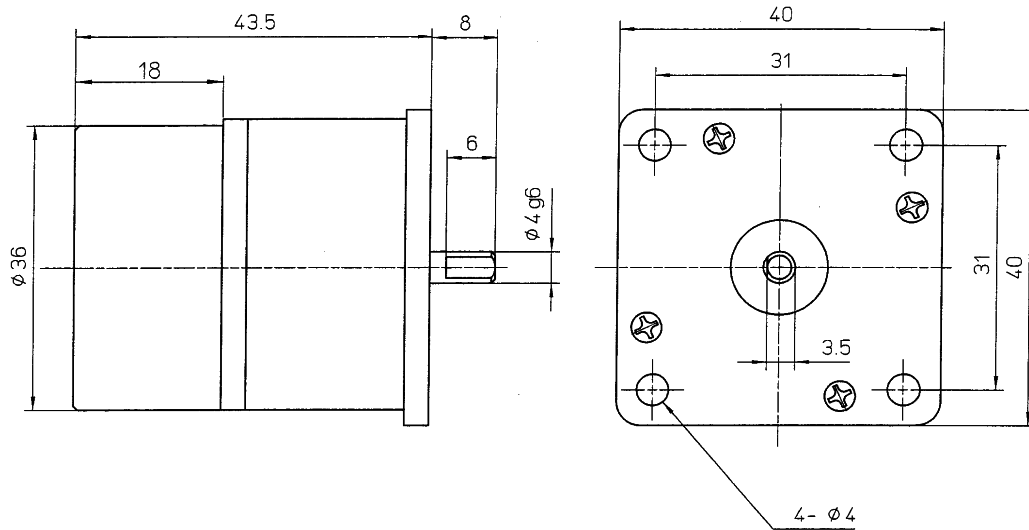

SPECIFICATION

MOTOR	RATED TORQUE (Nm)	4.0×10^{-2}
	RATED SPEED (S^{-1})	min. 2.5
	RATED OUTPUT (W)	min. 0.6
	HOLDING TORQUE (Nm)	min. 4.0×10^{-2}
	WEIGHT (g)	100
	ENCORDER RESOLUTION (P/R)	800
DRIVER	INPUT VOLTAGE (V)	DC 12 ± 0.5
	INPUT CURRENT (A)	max. 3.0
	WEIGHT (g)	about 550
OPERATING TEMPERATURE RANGE		$-10 \sim 50^{\circ}C$
STORAGE TEMPERATURE RANGE		$-20 \sim 60^{\circ}C$

CHARACTERISTIC

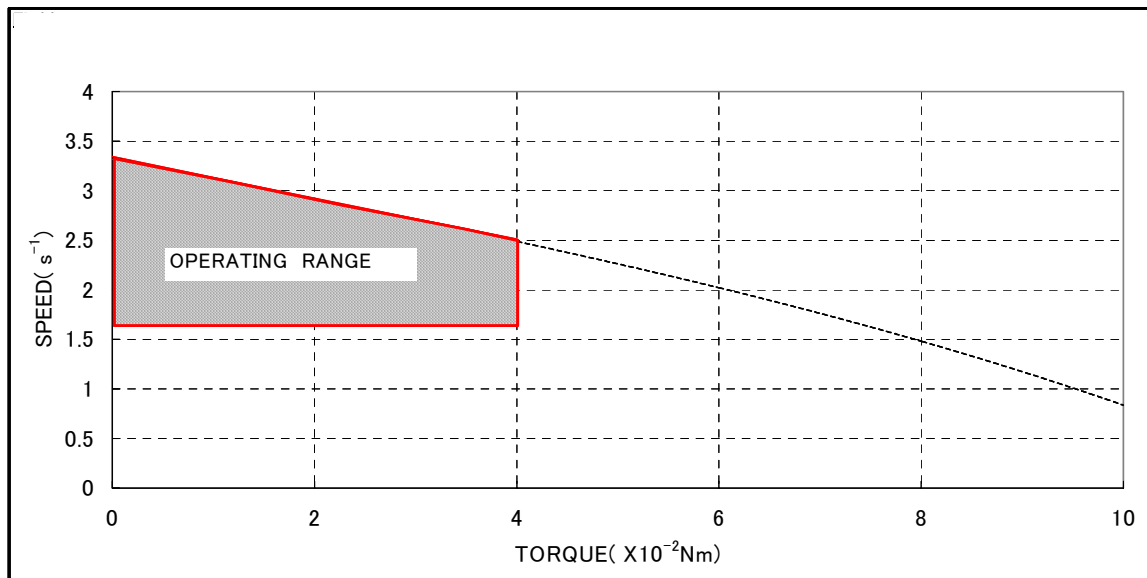

FUKOKU

Fukoku Co., Ltd.