

# ULTRASONIC MOTOR

USR60-V  
(VACUUM TYPE)

## DIMENSIONS

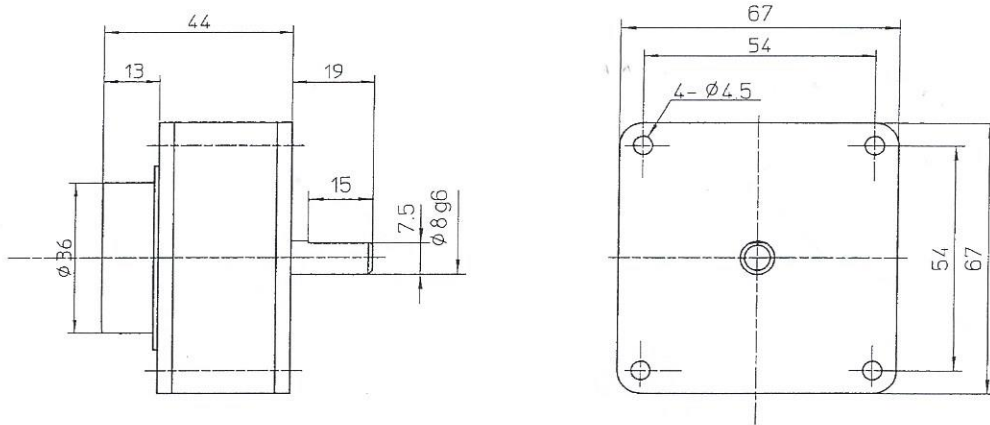

## SPECIFICATION

MOTOR	RATED TORQUE (Nm)	0.4
	RATED SPEED ( $S^{-1}$ )	min. 1.25
	RATED OUTPUT (W)	min. 3.1
	HOLDING TORQUE (Nm)	min. 3.1
	WEIGHT (g)	450
	ENCODER RESOLUTION (P/R)	1000
DRIVER	INPUT VOLTAGE (V)	DC12 $\pm$ 0.5
	INPUT CURRENT (A)	max. 4.0
	WEIGHT (g)	about 1,100
OPERATING TEMPERATURE RANGE		-10 $\sim$ 50 $^{\circ}$ C
STORAGE TEMPERATURE RANGE		-20 $\sim$ 60 $^{\circ}$ C

## CHARACTERISTIC

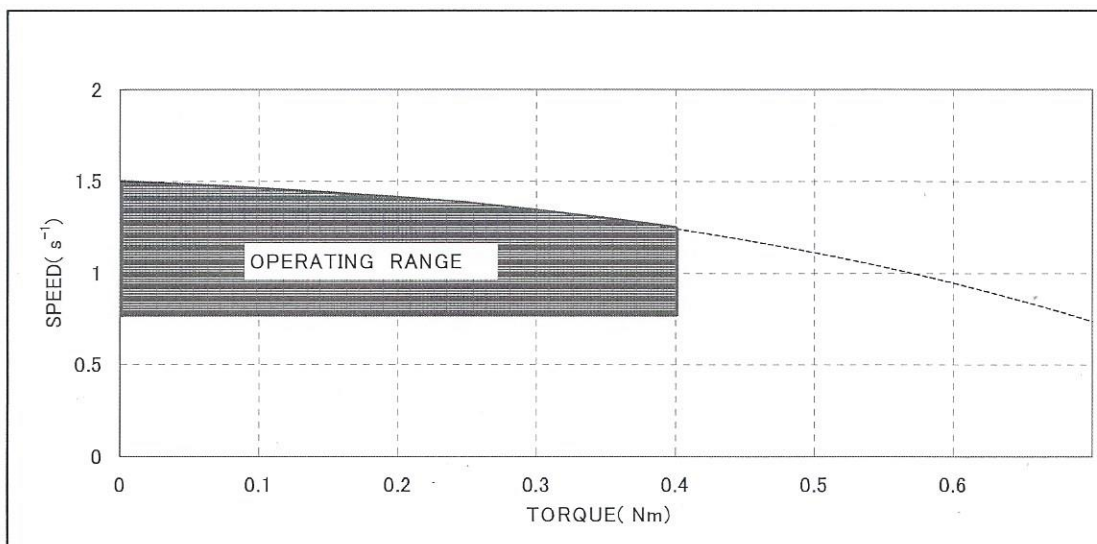

**FUKOKU**

Fukoku Co., Ltd.