

**LA75 - LINEAR AMPLIFIER FOR PIEZOELECTRIC
ACTUATORS - CA45 COMPACT STANDALONE
AMPLIFIER
PRODUCT AND WARRANTY INFORMATION**



**Version : 3.2.1
Date: 05/09/07**

CAUTION: READ BEFORE OPENING

For safety purposes these instructions must be read before use of this product.

This power amplifier is dedicated to multilayers piezoelectric actuators.

Only qualified personnel should work on or around this equipment and only after becoming thoroughly familiar with all warnings, safety notices, and procedures contained herein.

The successful and safe operation of this equipment is dependent on proper handling, installation and operation.

A "qualified person" is one who is familiar with the installation, construction and operation of the equipment and the hazards involved. In addition, he/she has the following qualifications :

- is trained and authorized to energize, de-energize, clean, and ground equipment in accordance with established practices,
- is trained in the proper care and use of protective equipment in accordance with established safety practices.

TABLE OF CONTENTS

1.	SYNOPTIC	3
2.	GENERAL DESCRIPTION	3
3.	MAIN CONNEXIONS	3
4.	OPERATING INSTRUCTION FOR THE LINEAR POWER SUPPLY, AC/DC CONVERTER, (LC75X)	3
5.	OPERATING INSTRUCTION FOR THE AMPLIFIER (LA75X).....	3
5.1.	General instructions	3
5.2.	Voltage control and current limitation.....	3
5.3.	Open/closed loop.....	3
5.4.	Using the push-pull mode (optional) (only for LA75X-X).....	3
5.5.	Using the optional board CI75-x.....	3
5.5.1.	Connection with CI75-x.....	3
5.5.2.	Offset setting.....	3
5.5.3.	Front panel of the CI75-x	3
5.6.	Using the optional board CPH75.....	3
5.6.1.	Connection with CPH75.....	3
5.6.2.	Front panel of the CPH75	3
6.	OPERATING INSTRUCTIONS FOR THE SG75 STRAIN GAUGES CONDITIONER.....	3
6.1.	General instructions	3
6.2.	Thermal effect.....	3
7.	OPERATING INSTRUCTIONS FOR THE ECS75 EDDY CURRENT SENSOR CONDITIONER	3
7.1.	General instructions	3
7.2.	Eddy current displacement sensors.....	3
8.	OPERATING INSTRUCTIONS FOR THE SC75 ANALOG CONTROLLER (OPTION)	3
8.1.	Introduction.....	3
8.2.	Terms and definition.....	3
8.3.	Pin out description	3
8.4.	Schematic pin out.....	3
8.5.	Board Layout	3
8.6.	Synoptic.....	3

9. TROUBLE SHOOTING.....	3
10. WARRANTY CONDITIONS AND EXCEPTIONS	3
11. INSPECTION UPON RECEIPT	3
12. AFTER-SALES SERVICE	3
ANNEX 1 : CONNECTIONS	3
Scheme of the cable connection for standard electrical configuration	3
Scheme of the cable connection for the Push Pull electrical configuration ..	3
ANNEX 2 : EFFECT OF THE CURRENT LIMITATION	3
Ratings of LA75X-x on piezo actuator series	3
ANNEX 3 : UNDERSTANDING THE FACTORY VERIFICATION SHEET	3
ANNEX 4 : LA75A-X TECHNICAL DATA SHEET	3
LA75B-x TECHNICAL DATA SHEET	3
LA75C TECHNICAL DATA SHEET	3
CA45 TECHNICAL DATA SHEET	3
ANNEX 4 : TROUBLE SHOOTING FORM	3

1. SYNOPTIC

The linear electronic LA75 multi-channel consists in a 19 inches casing to the following dimensions:

Rack 42F	Rack 63F-4U	Rack 84F-4U
Width : 260 mm	Width : 365 mm	Width : 470 mm
Length: 310 mm	Length: 310 mm	Length: 310 mm
Height: 160 mm	Height: 200 mm	Height: 200 mm

This electronic is a modular one; which means that a rack42F, for instance, may receive one power supply unit (LC75A) and up to 6 amplification channels, as well as sensors conditioning units:

- strain gauges sensors conditioner (SG75 unit),
- eddy current sensors conditioner (ECS75 unit).

The rear panel includes the main power connection, the ON/OFF switch and the fuses. The front panel includes the connections with actuators, orders and the switches to close the loop (SERVO) (Cf. Figure 1). The rack can include other boards described in separate documentations.

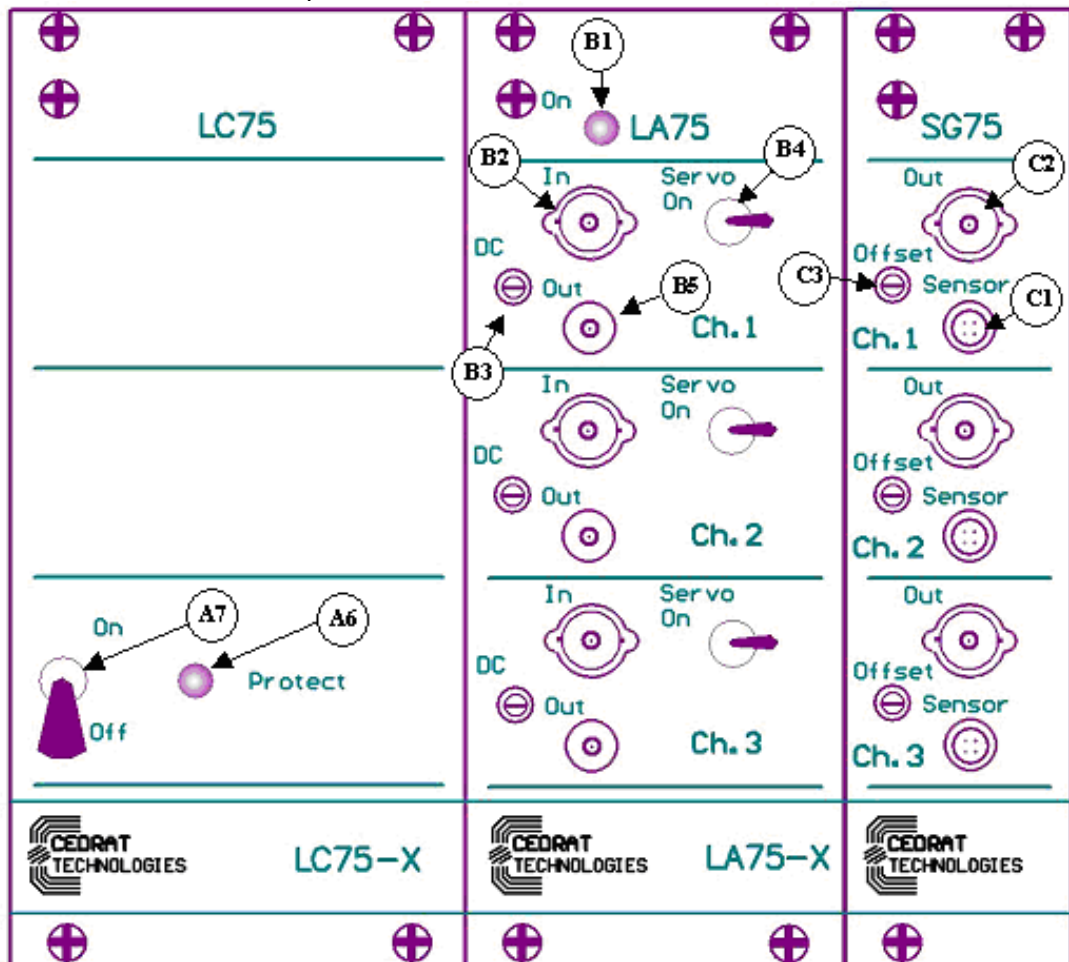

Figure 1 - Front panel of the LA75 power supply

Nota: " X " refers to the "A" ,"B" or "C" version of the driving electronics

REFERENCE	DESIGNATION
1 st module	Main power supply unit - LC75X
A6	Led protect
A7	Vp voltage switch
2 nd module	Linear amplifier - LA75X
B1	Led power supply presence
B2	Order BNC connector - channel 1
B3	DC offset order potentiometer (10 turn screw)- channel 1
B4	Closed loop selector (SERVO ON / OFF) - channel 1
B5	LEMO connector for piezo actuator (3 pins lemo for push-pull option)- channel
3 rd module	SG75 - Strain Gauge conditioner (optional)
C1	LEMO connector for the gauges bridge - channel 1
C2	BNC connector of the conditioner signal response - channel 1
C3	Regulation potentiometer of the offset (10 turn screw) - channel 1

WARNING

A special care in the use of the LEMO connections should be taken in plugging and unplugging them: you have to pull onto the connector and not the cable.

It is strictly forbidden to connect the electrical output channels in parallel.

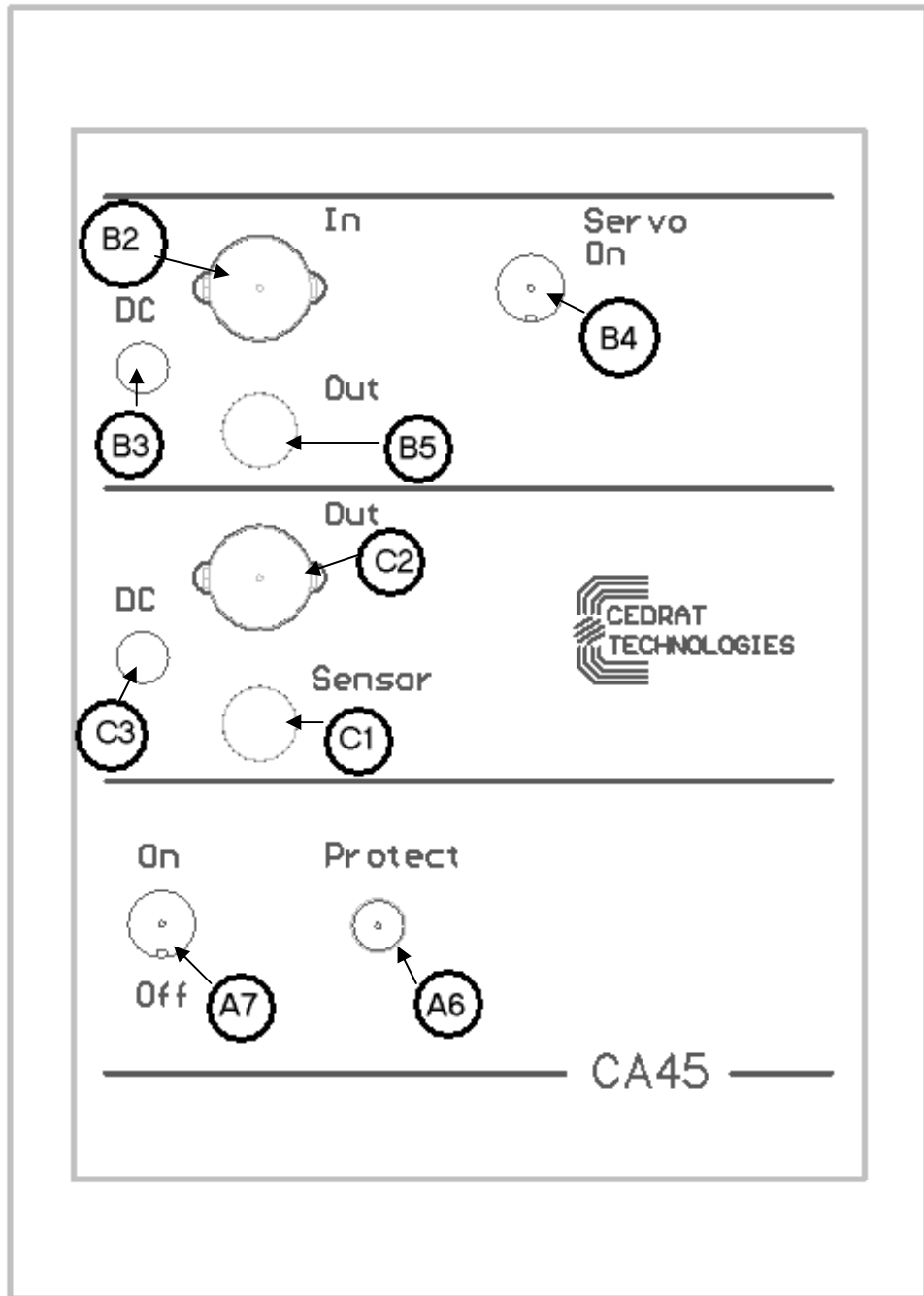

Figure 2 - Front panel of the CA45 compact standalone amplifier

2. GENERAL DESCRIPTION

The linear electronic LA75 is dedicated to the supply and control of piezoelectric actuators based on multi-layers piezoelectric ceramics such as APA or PPA from CEDRAT TECHNOLOGIES. The LA75X consists in a power supply with a maximal power given in the attached technical data sheet, including:

- A linear power supply (LC75X) providing a continuous voltage from the main power (1st module),
- A linear amplifier (LA75X) dedicated to capacitive load allowing excitation of piezoelectric actuators between -20 and 150 V (2nd module),
- A strain gauge conditioner (SG75) allowing to measure the displacement of piezoelectric actuators equipped with gauges (optional module),
- A servo controller (SC75) allowing to close the loop and to insure a feedback control on the actuator (optional module)

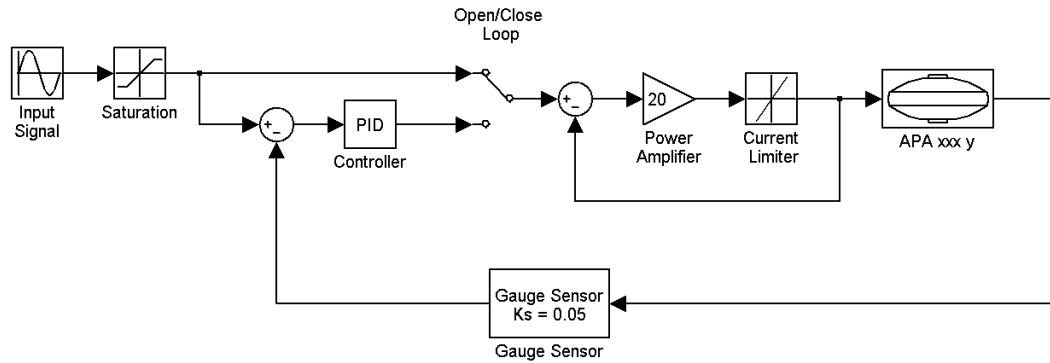

Figure 3 - Synoptic of the electronic control of a piezo actuator

The CA45 compact standalone amplifier consists in a board including the linear power supply providing a continuous voltage from the main power, the linear amplifier, the strain gauge conditioner (option) and a servo controller (SC75) (option).

3. MAIN CONNEXIONS

Main: 230 V AC / 50 Hz			
CA45	LC75A	LC75B	LC75C
1A fuse : 250 V F type*	0.5 A fuse 1: 250 V F type 0.5 A fuse 2: 250 V F type	1 A fuse 1: 250 V F type 1 A fuse 2: 250 V F type	6.3 A fuse 1: 250 V T type 6.3 A fuse 2: 250 V T type
Main: 110 V AC / 60 Hz (on request)			
CA45	LC75A	LC75B	LC75C
2 A fuse 1: 250 V F type*	1 A fuse 1: 250 V F type 1 A fuse 2: 250 V F type	2 A fuse 1: 250 V F type 2 A fuse 2: 250 V F type	8 A fuse 1: 250 V T type 8 A fuse 2: 250 V T type

* CMS fuse : the customer is not allowed to change it without authorisation

The rack equipped with a main selector (several configurations) that allows the user selecting by himself the main. For the CA45, the selector is inside the RK12F rack.

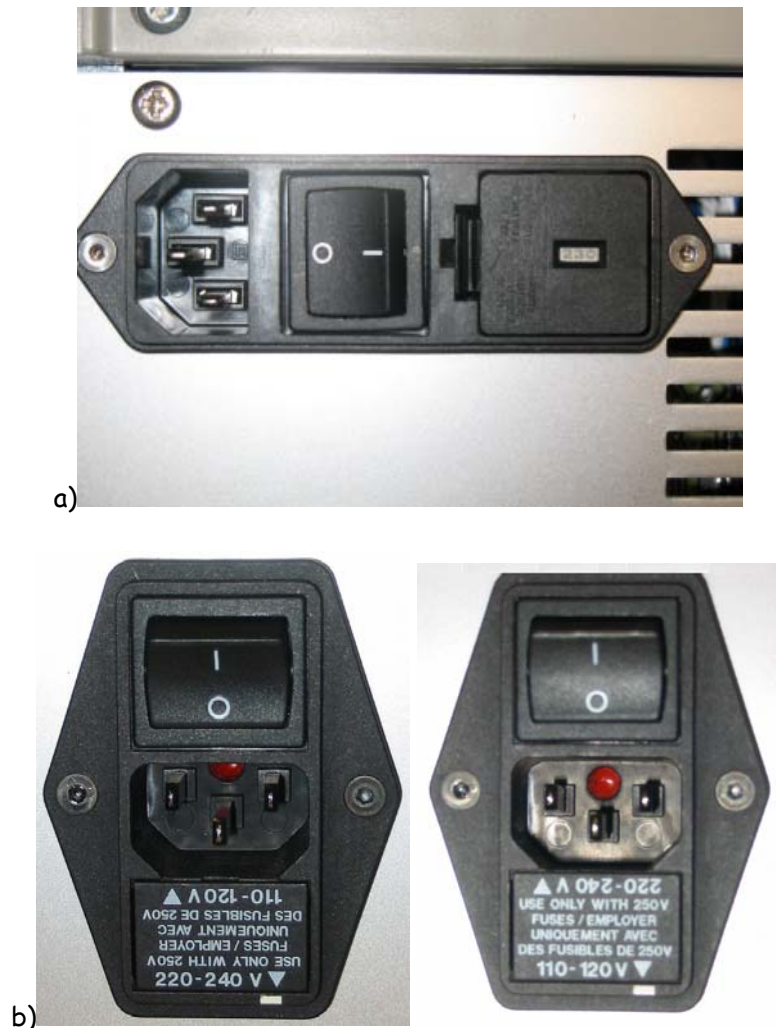

Figure 4 : Main selector a)RK42F rack, b) RK63F4U rack

4. OPERATING INSTRUCTION FOR THE LINEAR POWER SUPPLY, AC/DC CONVERTER, (LC75X)

This module produces from the mains, the regulated DC voltage to the amplifier functioning needs:

- +15 / -15 V : signal processing,
- +150 V : positive direct voltage,
- -20 V : negative direct voltage.

It is possible to neutralise supplied power voltages by using the switch A7. This switch is the easiest way to disable the piezoelectric actuator as soon as required. However, few seconds are necessary to come to a completely discharged actuator.

This module is protected against over temperature, over voltage and over current conditions.

It is recommended to keep free space all around the electronic rack while driving in order to make the ventilation easier and to obtain the nominal performance of the driving electronics.

Note: Do use the tilt feet for the LA75B and LA75C rack versions.

5. OPERATING INSTRUCTION FOR THE AMPLIFIER (LA75X)

5.1. General instructions

The linear amplifier allows to apply to the actuator a signal comparable to the order's one, with a gain of 20 (see Figure 5).

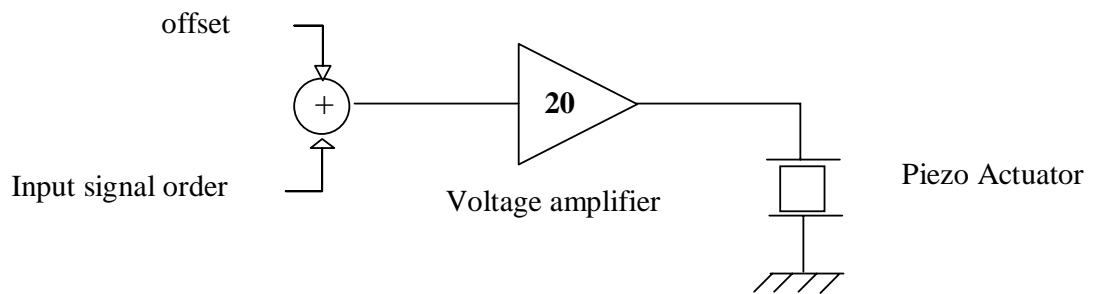

Figure 5 - Principle of linear voltage amplifier

The order may be applied in two different and complementary manners:

- static offset (potentiometer): B3 screw,
- dynamic order: B2 connectors.

These two signals are added and their sum should fall between -1V and 7.5V.

To connect the actuator to the voltage amplifier, the standard cable available is a coaxial LEMO connector in one end and 2 banana plugs in second end (see Annex 1).

5.2. Voltage control and current limitation

If the order signal is below -1 V or above 7.5 V, a protective diode and the power amplifier saturation will clamp the signal so that the voltage applied to the actuator stays roughly between -20 V and 150 V.

There is some limitation to the constant gain of the amplifier. Indeed, when the variation speed of the input signal (order) increases, the current limitation of the amplifier limits the slew rate of the output voltage. This current limitation varies with the power amplifier (LA75X) version (see annex 3).

Note: the use of an digital input signal (B2) may generate parasitic noise so that an additional filter may be necessary.

5.3. Open/closed loop

By default, the open/closed loop selector should be set on the mode open loop (SERVO OFF): in that mode, the amplifier applies a voltage gain of 20 to the input.

A displacement sensor, its conditioner and a servo controller will be necessary to use the closed loop (SERVO ON); otherwise the order will be set to zero.

5.4. Using the push-pull mode (optional) (only for LA75X-X)

For some piezoelectric devices such as the piezoelectric tilts or XY stages, it is necessary to supply two actuators simultaneously. A zero positioning is achieved with an electrical centring. Such a configuration could easily be achieved by using one amplifier, according to the figure shown below.

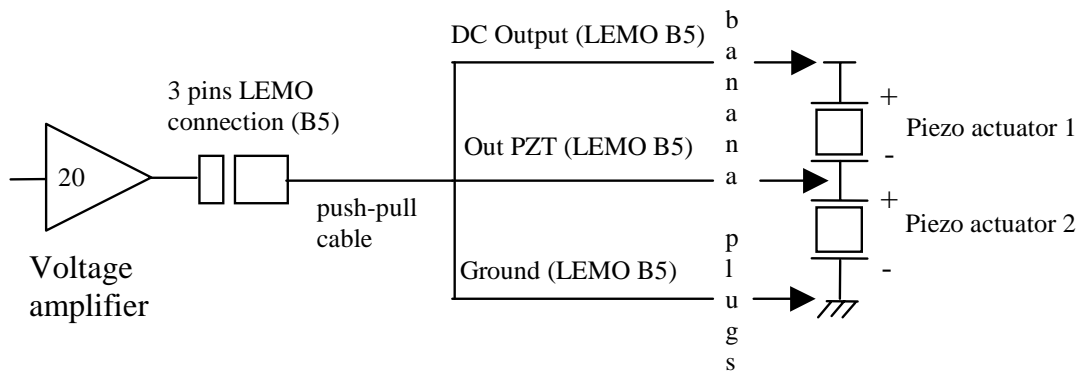

Figure 6 - Principle of power supply for an actuator centred electrically

To use this optional mode, a DC regulator shall be implemented inside the LA75 and a modified lemo plug shall be integrated in the front of the LA75. That is why a special cable is available at CEDRAT TECHNOLOGIES including a 3 pins LEMO connector in one end and 4 banana plugs in second end is necessary (see Annex 2).

Note: the electrical charge seen by the power amplifier is twice the capacitance of a single actuator, so the bandwidth is twice smaller than for a single actuator.

WARNING

In that mode where one of the actuator is constantly under direct voltage, it is recommended to limit in time the supply of the actuator. Use the A7 switch when the actuator does not need to be supplied.

5.5. *Using the optional board CI75-x*

One alternative, using the Command Inverter board CI75-x, to power a mechanical push-pull system is to use two amplifiers. The first amplifier will receive the direct command signal meanwhile the second have to receive a complementary signal of the first channel.

Due to this way of excitation, the mechanical system has to be polarised at its centered position through the command offset.

Taking into account the assumption that the command can vary between -1V and 7.5V and that the mechanical centered position is obtained at the middle level command range of $(8.5 / 2) - 1V = 3.25V$, The complementary command is obtained from the first command through the following relationship :

$$V_{ch2} = 3.25V - V_{ch1}$$

The offset for channel 1 have to be set to 3.25V.

5.5.1. *Connection with CI75-x*

The input command voltage for channel 1 has to be connected to the channel 1 B2 of the LA75-x and at the input of the CI75-x D1 through the front panel. The output channel of the CI75-x D2 has to be connected to the input of channel 2 B6 of the LA75-x through the front panel.

5.5.2. *Offset setting*

The offset voltage has to set to 0V on the first channel of the LA75-x B3.
The offset voltage has to set to 0V on the second channel of the LA75-x B7.
The offset voltage D3 has to set to 6.5V on the CI75-x.

5.5.3. Front panel of the CI75-x

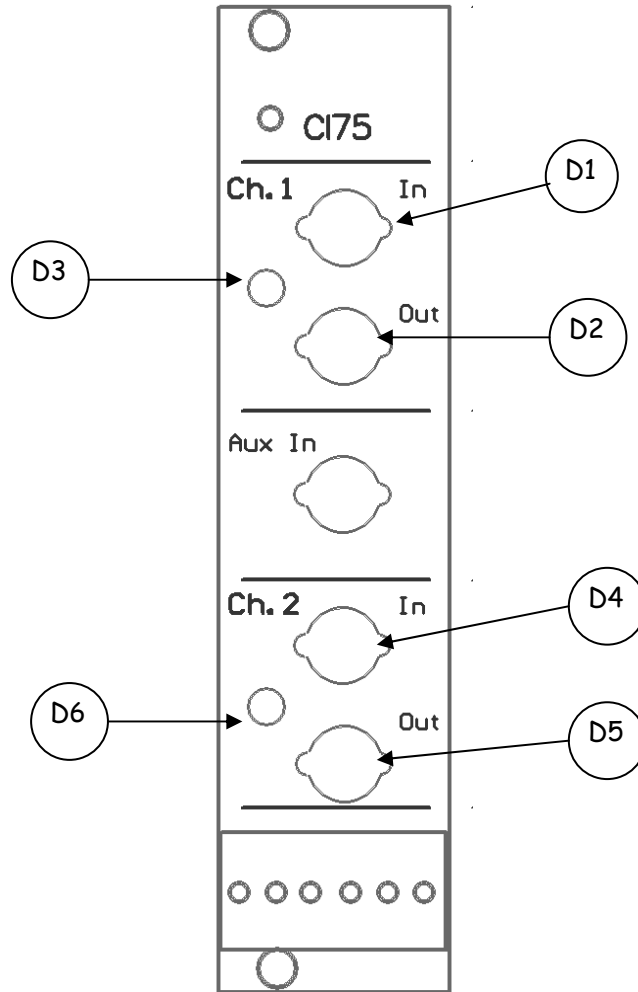

Figure 7 : - Front panel of the CI75-x board

5.6. Using the optional board CPH75

The CPH75 board is an analog dephasing circuit that produces an additional command with a settable out of phase. The range of frequency is 500 - 5000 Hz (can be modified at the factory under customer's request). The achievable phases range is from -160° to 160° .

5.6.1. Connection with CPH75

The user command should be provided to the In connection E1.

The following operations are performed :

E4 : Out1 = In

E6 : Out2 = In*Phase

Should Inv E3 is set high (Analog 0-10 V), the following operations are performed :

E6 : Out2 = In
 E4 : Out1 = In*Phase

It can be noticed that through the Inv command signal, the relative phase between Out1 and Out2 can be positive or negative.

5.6.2. Front panel of the CPH75

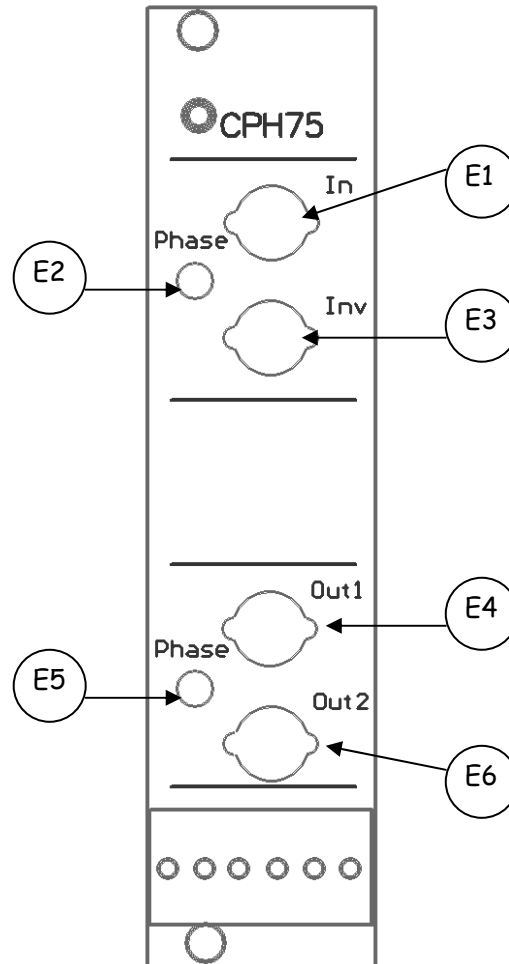

Figure 8 : - Front panel of the CPH75 board

6. OPERATING INSTRUCTIONS FOR THE SG75 STRAIN GAUGES CONDITIONER

6.1. *General instructions*

This module allows reading up to three strain gauges bridges. For each one of them, you can:

- Read the signal emitted by the conditioner (C2),
- Adjust the offset (C3).

The gain and the offset of the conditioner are adjusted at the factory on a gauge bridge set on the piezoelectric actuator, but only the offset is accessible to the user (C3). If you wish to use the conditioner with another actuator, it may be necessary to modify the gain at the factory.

6.2. *Thermal effect*

The strain gauges solution is the easiest way to operate a piezoelectric actuator in a closed loop. The best accuracy that can be achieved with this sensor is around 0.025%.

However, the strain gauges sensor is temperature dependent, so that the offset may vary with temperature.

7. OPERATING INSTRUCTIONS FOR THE ECS75 EDDY CURRENT SENSOR CONDITIONER

7.1. *General instructions*

The ECS75 card includes up to 2 channels of Eddy Current sensors, which have been calibrated at the factory. Only the offset can externally corrected (F2, F5 trimmers).

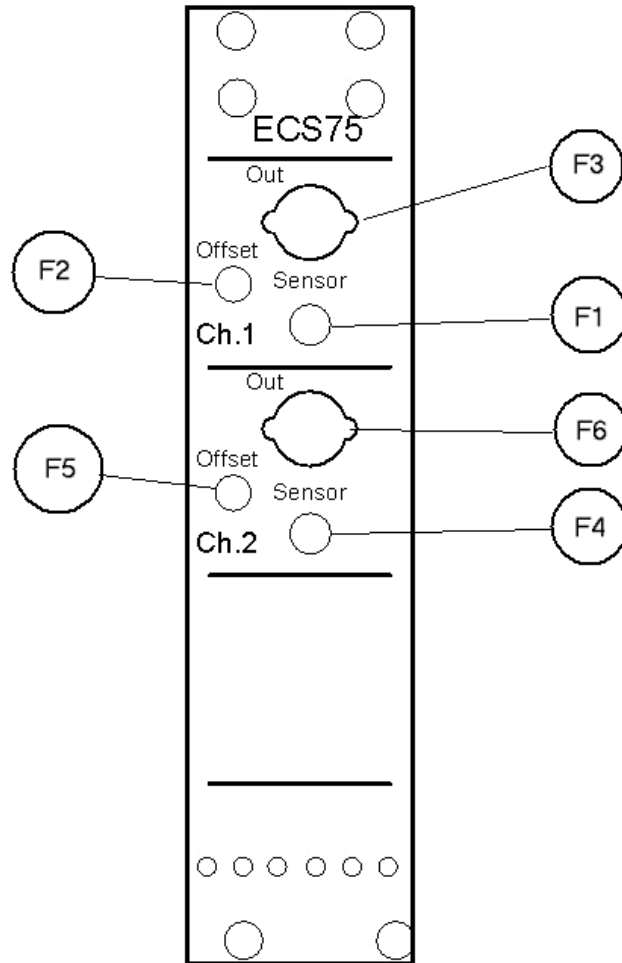

Figure 9 : - Front panel of the ECS75-2 board

7.2. Eddy current displacement sensors

The Eddy Current displacement sensor is a non contact proximity sensor using the eddy current effect generated by the probe in a (preferably) nonferrous material target. The eddy current changes the impedance of the probe, which is read by the conditioner.

Although the probe is calibrated with the target, the gain is somewhat dependent on the angle between the probe and the target, the target's thickness. of the

8. OPERATING INSTRUCTIONS FOR THE SC75 ANALOG CONTROLLER (OPTION)

8.1. Introduction

This mezzanine (optional) board SC75 is stackable on the amplifier board and allow the support of three channels. The selection of a channel on the board is done through soldered jumper settings S1, S2, S51.

Only one controller is available on the SC75 board. Only the input and output channel selections is configurable on a single board. Three boards with appropriate input/output selection are necessary for a 3 channel application.

This a PI controller board¹ with an adjustable filter. Other settings are possible in factory according to the filled in SC75 setting form ANNEX 5).

8.2. Terms and definition

Resolution: the resolution is the smallest displacement that the sensor (and its conditioning electronic) is able to measure. The resolution is preferably given with a relative value (a percentage of the total range of measurement).

Precision error in closed loop: the precision error is the difference between the command and the effective value of the displacement. Several contributors play a role in the precision error (resolution of the sensor, sensitivity to external parameters - ageing, temperature ...), corrector error. The precision error is preferably given with a relative value (a percentage of the total displacement).

The following table gives the performances of the position sensor

Sensor type	Resolution	Precision error	Most contributing factors
Strain Gauge (SG)	10^{-4}	10^{-3}	Temperature
Eddy Current Sensor (ECS)	10^{-5}	10^{-4}	Temperature ; material of the target
Capacitive sensor (CS)	10^{-5}	5.10^{-5}	Tilt effect between the target and the probe Humidity

Table 1 : Performances of the sensors

8.3. Pin out description

¹ Standard

JP1		
1	GND	Ground
2	SDI / MISO	SPI Master Serial Data In (MISO)
3	SDO / MOSI	SPI Master Serial Data out (MOSI)
4	SC / SCLK	SPI Serial Clock
5	GND	Ground
6	+15	+15V supply
7	-15	-15V supply
8	+5	+5V supply
9	GND	Ground
10	CS_Ad0	Chip Select address 0 / LSB
11	CS_Ad1	Chip Select address 1
12	CS_Ad2	Chip Select address 2 / MSB
13	GND	Ground
14	GND	Ground

Table 2: Connector Jp1 Pin Out

JP2			
1	PID3	Controler output	Channel 3
2	MeasSensor3	Same as SG Out but inverted or not depending board setting	Channel 3
3	SGOut3	Strain gages conditionner output	Channel 3
4	Order3	Command signal	Channel 3
5	GND		
6	PID1	Controler output	Channel 2
7	MeasSensor2	Same as SG Out but inverted or not depending board setting	Channel 2
8	SGOut2	Strain gages conditionner output	Channel 2
9	Order2	Command signal	Channel 2
10	GND		
11	PID1	Controler output	Channel1
12	MeasSensor1	Same as SG Out but inverted or not depending board setting	Channel1
13	SGOut1	Strain gages conditionner output	Channel1
14	Order1	Command signal	Channel1

Table 3 Connector Jp1 Pin Out

8.4. Schematic pin out

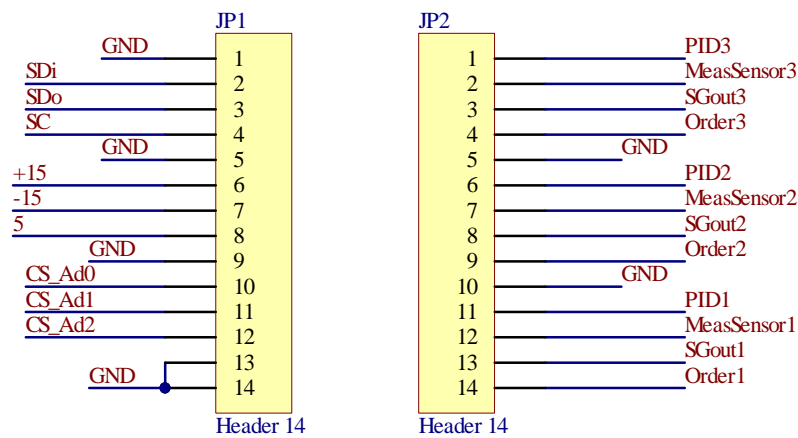

Figure 10: Schematic pin out of the connecto

8.5. Board Layout

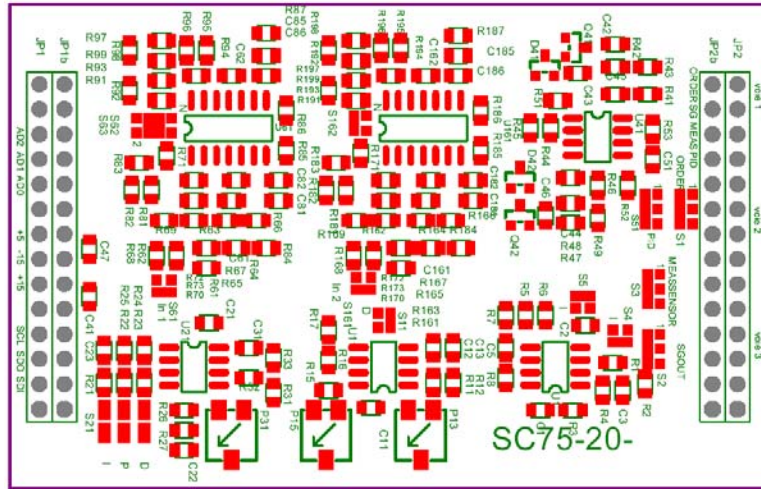

Figure 11: Top view of the board

8.6. Synoptic

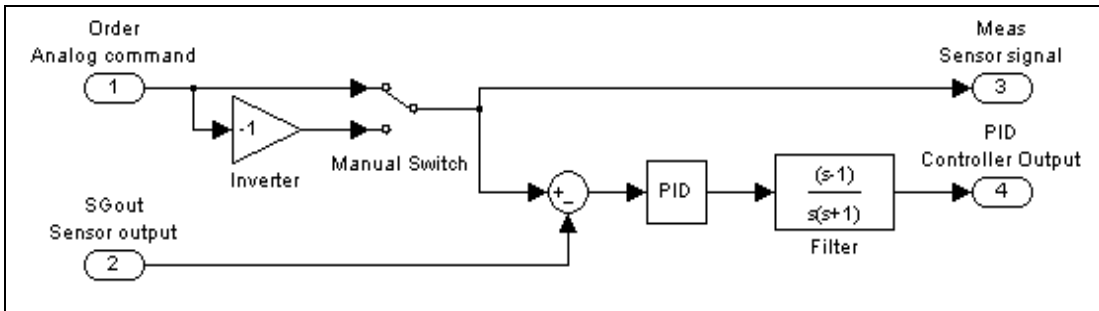

Figure 12: Synoptic of the controller

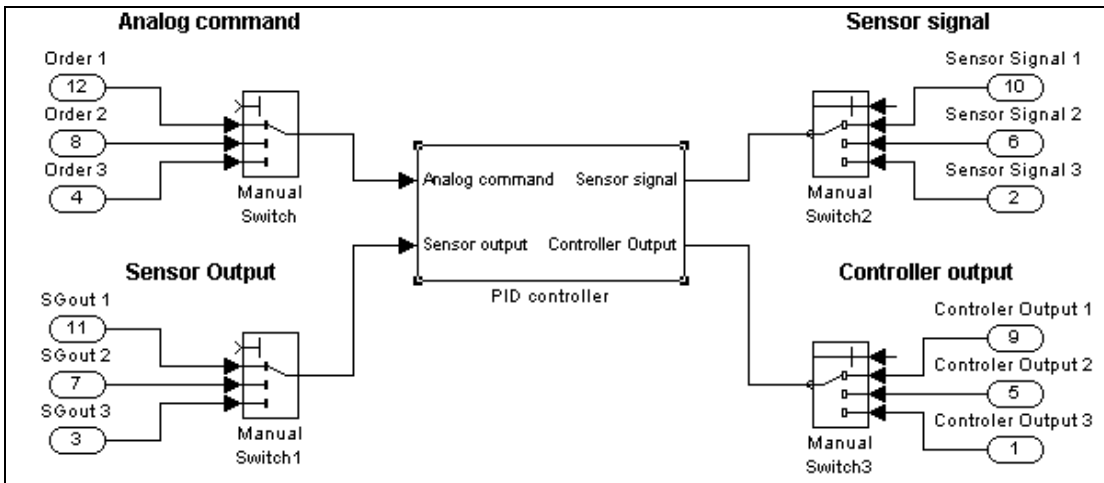

Figure 13: Address configuration for multi-channel configuration

9. TROUBLE SHOOTING

PROBLEMS: THE PLUGGED PIEZO ACTUATOR DOES NOT MOVE WHILE THE REAR CONNECTION AND THE A7 ARE SWITCHED ON

ACTION	POSSIBLE CAUSES
<p>Check the led A6 :</p> <p>a) If A6 is off</p> <ul style="list-style-type: none"> - check the main cable and the fuses at the rear panel <p>b) If A6 is red</p> <ul style="list-style-type: none"> - check the connection lines to the piezo actuator / disconnect every LEMO cable. Test the electronics with the unplugged and plugged piezo actuator, as follows - switch A7 off <ul style="list-style-type: none"> If A6 is green <ul style="list-style-type: none"> - switch A7 on <p>if the electronics works,</p> <p>if the electronics doesn't work,</p> <p>If A6 is red</p> <ul style="list-style-type: none"> - Wait for 10 minutes and switch A7 on <p>if the electronics works,</p> <p>if the electronics doesn't work,</p>	<ul style="list-style-type: none"> - misconnection with main cable or burnt fuses - The electronics is in protection - May be a short circuit through the cable connection or through the piezo actuator occurred - an external parasitic noise might have disturbed it - a breakdown is certain - The electronics was in thermal protection and needed to cool itself down - a breakdown is certain

PROBLEMS: INCOHERENT RESPONSE FROM THE ACTUATOR IN OPEN LOOP

ACTION	POSSIBLE CAUSES
<p>Check the output signal (B5)</p> <p>If the DC offset is wrong, turn (B3) to settle it*</p>	<ul style="list-style-type: none"> - the DC offset may be wrong

PROBLEMS: INCOHERENT RESPONSE FROM THE ACTUATOR IN CLOSED LOOP

ACTION	POSSIBLE CAUSES
<p>Go back in mode SERVO OFF (B4) and check the sensor's response (C2)**</p>	<ul style="list-style-type: none"> - the strain gauges offset (C3) may be wrong

* 10 turns potentiometers are used: do not hesitate to rotate the potentiometers and keep attention to the 'clac' noise arising at the end of the trimmer range.

** Adjusting the Strain Gauge offset

- Apply a command of 0V (by a 50 Ohms BNC connector on B2 for instance),
- Check that the voltage output on B5 is nearly zero,
- Adjust the potentiometer B3 to get the output B5 near zero,
- Measure the output of the Strain Gauge conditioner C2,
- Adjust the potentiometer C3, so that the output C2 is 0.38 V

One has :

$$V_{sg} = (\text{SetPoint}_{LA} + 1) / \text{MaxAmplitude}_{LA} * \text{MaxAmplitude}_{SG} - 0,5$$

With :

$$\text{MaxAmplitude}_{LA} = 8.5$$

$$\text{MaxAmplitude}_{SG} = 7.5$$

The customer is not entitled to modify the power supply or the linear amplifier. The only manipulations allowed to him are described in the set here above, including the replacement of (the) external fuse(s.). For any other matter or breakdown suspicion, we suggest the customer to contact the local vendor.

10. WARRANTY CONDITIONS AND EXCEPTIONS

The equipment is warranted for one year, including parts and labour, and only under standard technical conditions as outlined above and expressly mentioned in the technical data sheet. Repairs will be carried out at CEDRAT TECHNOLOGIES or through your vendor. Shipping, handling and insurance costs to return a part for repair must be paid by the customer.

Interventions or attempts to service or repair the LA75 by any unauthorised persons will invalidate this warranty.

11. INSPECTION UPON RECEIPT

This product has been inspected and shown to operate correctly at the time of shipment, as verified by the Factory Verification Form that accompanies the power supply

Immediately upon receipt of the product, it should be inspected carefully for any signs of damage that may have occurred during shipment. If any damage is found, a claim should be filed with the carrier.

The package should also be inspected for completeness according to the enclosed packing list. If an order is incorrect or incomplete, contact your distributor.

CEDRAT TECHNOLOGIES recommends the customer to keep the original package for any further carriage of the electronic product.

12. AFTER-SALES SERVICE

If a device requires service, please contact CEDRAT TECHNOLOGIES or your local vendor. Please include the device model and serial number in all correspondence with CEDRAT TECHNOLOGIES or your vendor.

ANNEX 1 : CONNECTIONS

Scheme of the cable connection for standard electrical configuration

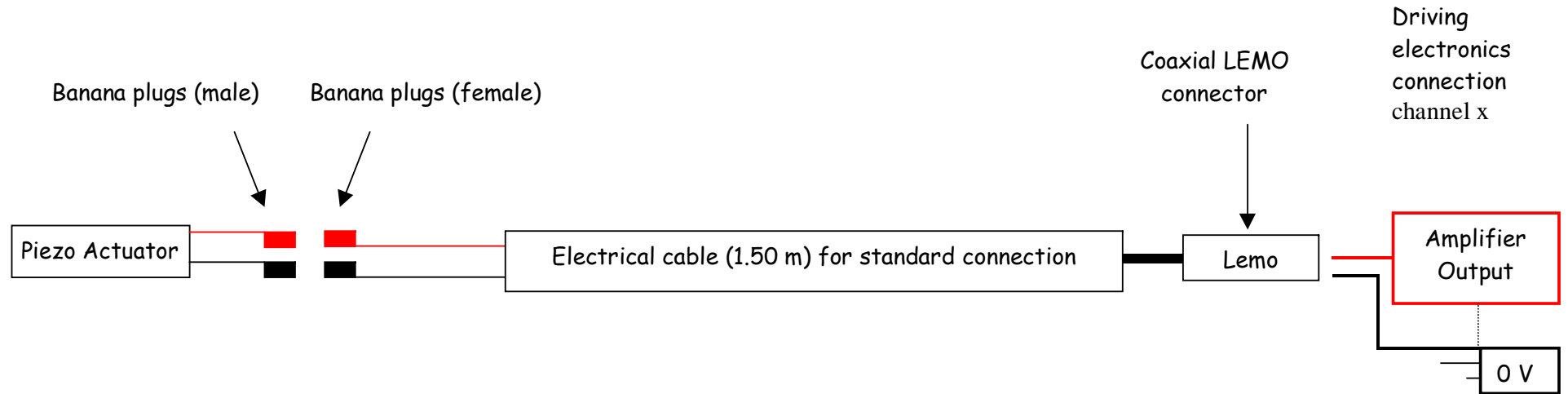

Scheme of the cable connection for the Push Pull electrical configuration

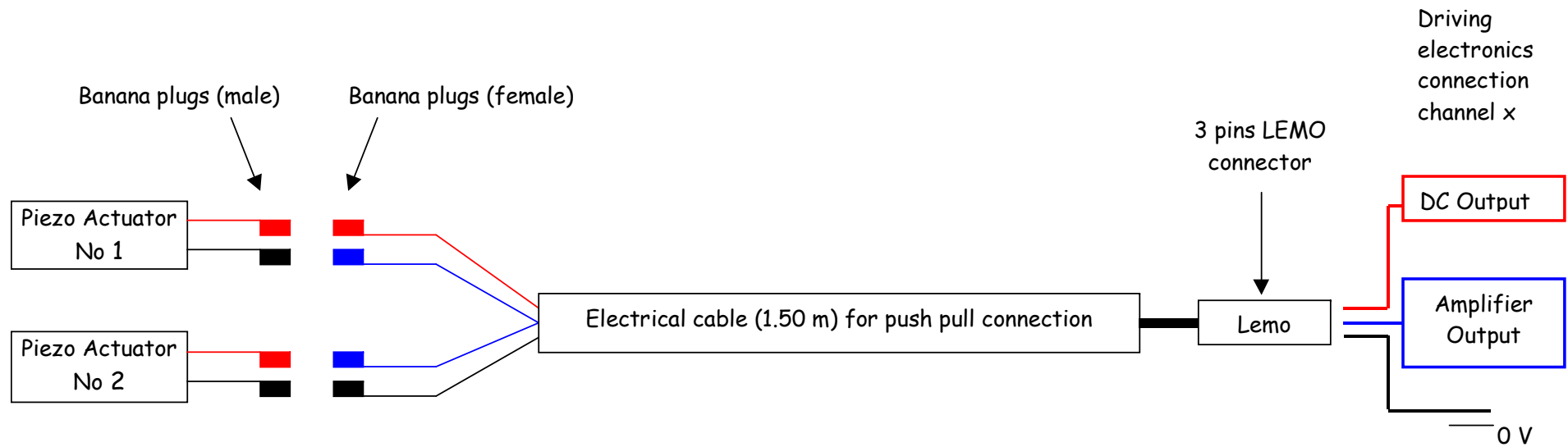

ANNEX 2 : EFFECT OF THE CURRENT LIMITATION

With a linear amplifier the applied voltage to the actuator is directly proportional to the input signal. The gain of the power amplifier LA75x is set to 20.

So, to obtain the whole stroke of a given actuator, one should input a signal varying from -1V to 7.5V. The applied voltage on the actuator will then vary from -20 to 150V.

There is some limitation to the constant gain of the amplifier. Indeed, when the variation speed of the input signal (order) increases, the current limitation of the amplifier limits the slew rate of the output voltage. The current provided to a piezo ceramic is depending on its capacitance and on the variation speed of the applied voltage.

The current for a capacitive load is given by the following expression:

$$I_{piezo} = C_{piezo} \times \frac{dv}{dt}$$

For a given current limitation, the shortest load time is given by:

$$t_{load} = \frac{\Delta V \times C_{piezo}}{I_{lim}}$$

The max frequency for a triangle signal is given by:

$$f_{triangle\ max} = \frac{I_{lim}}{2 \times \Delta V \times C_{piezo}}$$

If we consider a sine signal, then the maximal frequency is given by:

$$f_{sin\ max} = \frac{2 \times I_{lim}}{\Delta V \times C_{piezo} \times 2\pi}$$

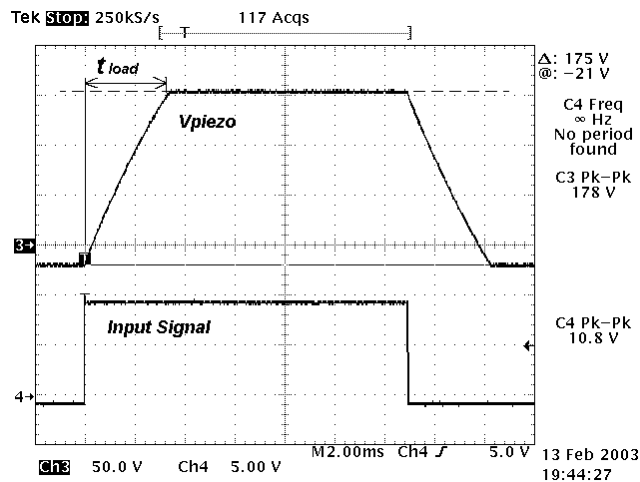

Figure A 1 - The current limitation limits the voltage slew rate of the piezo

Type of linear amplifier	CA45	LA75A	LA75B	LA75C
Current limitation (A) per channel	0.03	0.09	0.36	2.4

Ratings of LA75X-x on piezo actuator series

Considering a scale variation of $\Delta V = 120V$ and taking into account the current limitation of the LA75X, the following table summarises the load time and bandwidth values for different piezo actuator series :

Actuator serie	Capacitance μF	Load time @ 120 V (ms)			
MLA_2*5*10 - APA - XS	0,25	1,00	0,33	0,08	0,01
MLA_5*5*20 - APA - S, SM	1,55	6,20	2,07	0,52	0,08
APA - M	3,15	12,60	4,20	1,05	0,16
APA - ML	20,00	80,00	26,67	6,67	1,00
APA - L	40,00	160,00	53,33	13,33	2,00
APA - XL	110,00	440,00	146,67	36,67	5,50
MLA_5*5*10 - PPA10M	0,70	2,80	0,93	0,23	0,04
PPA20M	1,40	5,60	1,87	0,47	0,07
PPA40M	2,70	10,80	3,60	0,90	0,14
PPA40L	13,30	53,20	17,73	4,43	0,67
PPA60L	20,00	80,00	26,67	6,67	1,00
PPA80L	26,60	106,40	35,47	8,87	1,33
PPA40XL	24,00	96,00	32,00	8,00	1,20
PPA80XL	48,00	192,00	64,00	16,00	2,40
PPA120XL	72,00	288,00	96,00	24,00	3,60

(*) the capacitance values are those at low frequency and room temperature.

ANNEX 3 : UNDERSTANDING THE FACTORY VERIFICATION SHEET



Linear Amplifier Factory Verification

Stamp and signature

Rack n° 03007
Mains 230Vac / 50 Hz
LA75B-03013
CH 1

Date of test (DD/MM/YY)
24/10/2005
Test performed by
AP

Representative load

Electrical Load: 2.3 μ F

Input frequency: 50 Hz

Rise time (10 - 90%): 0,88 ms
Acceptance limits (ms): $0.82 \leq Tr \leq 1.01$
Fall time (90 - 10%): 0,85 ms
Acceptance limits (ms): $0.82 \leq Tf \leq 1.01$

Verification tests

Output voltage to Square input voltage

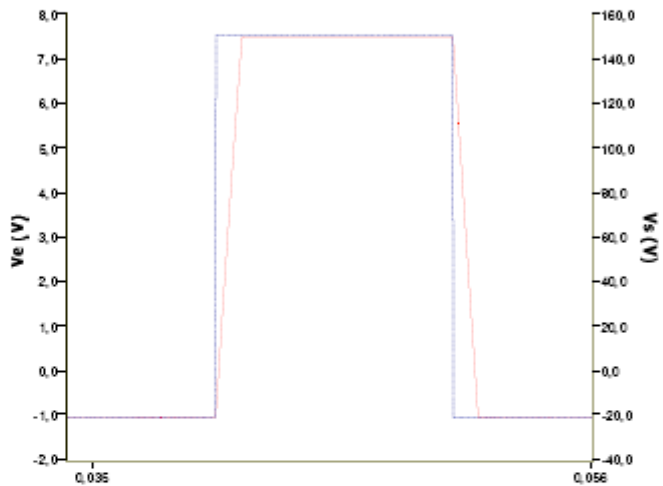

Representative load

Electrical Load: 2.3 μ F

Input frequency: 250 Hz

Gain (V_s/V_e): 20,1
Acceptance limits (V/V): $19.8 \leq G \leq 20.2$
Output offset for null input: -0,07V
Acceptance limits (V): $-0.1 \leq \text{Offset} \leq 0.1$

Verification tests

Linearity Output voltage vs. Input voltage

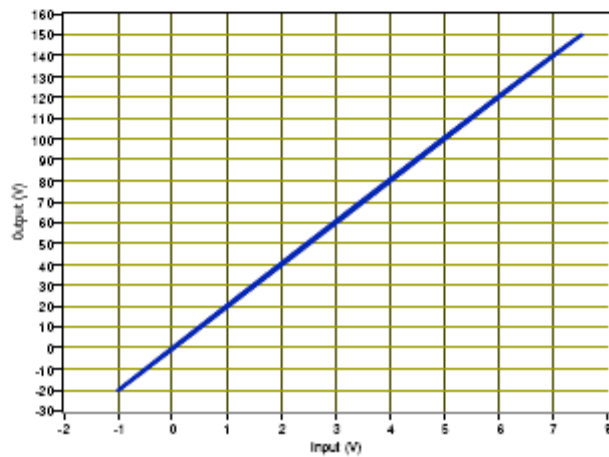

Labview71 MaieV1.2P1.1Ca-1101.11.1



Linear Amplifier

Factory Verification

Rack n° 04-00xx
SG75 n° 04-00xx

Date of test (DD/MM/YY)

CH.1

Test performed by

Actuator APA230L n° 05-007

Actuator reference used for the calibration

Test 3: SG75 Output voltage to Sine Input voltage in Closed loop

Output of the SG conditioner calibration

Measurement apparatus:
TDS 3014

Input frequency : xx Hz

Oscilloscope:
Ch.1: Input Voltage (Probe x1)
Ch.2: Output Voltage (Probe x1)

Gain SG75: 31.47 $\mu\text{m/V}$

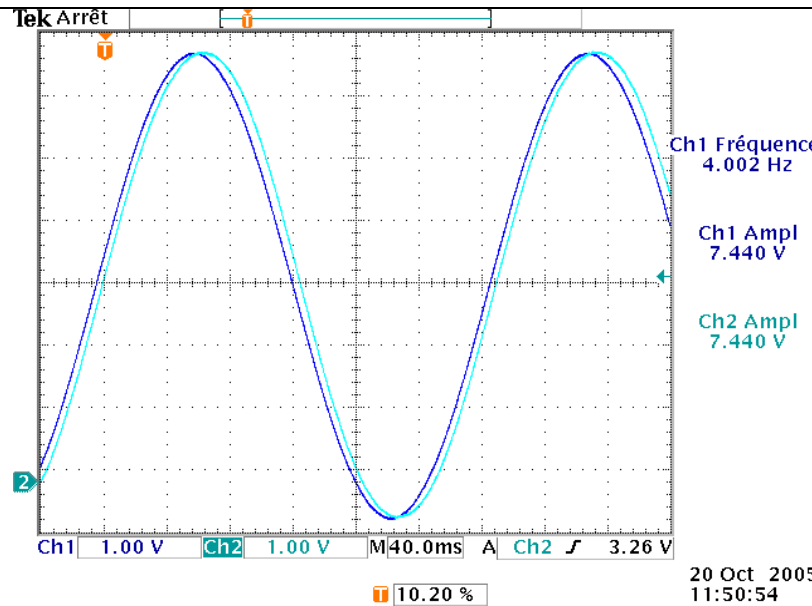

Test 4: SG75 Output voltage versus sine Input voltage in Closed loop

Electrical conditions:
Load: APAxxxY

Measurement apparatus:
TDS 3014

Input frequency : 0.5 Hz

Oscilloscope:
Ch.1: Input Voltage (Probe x1)
Ch.2: Output Voltage (Probe x1)

Gain SG75: 31.47 $\mu\text{m/V}$

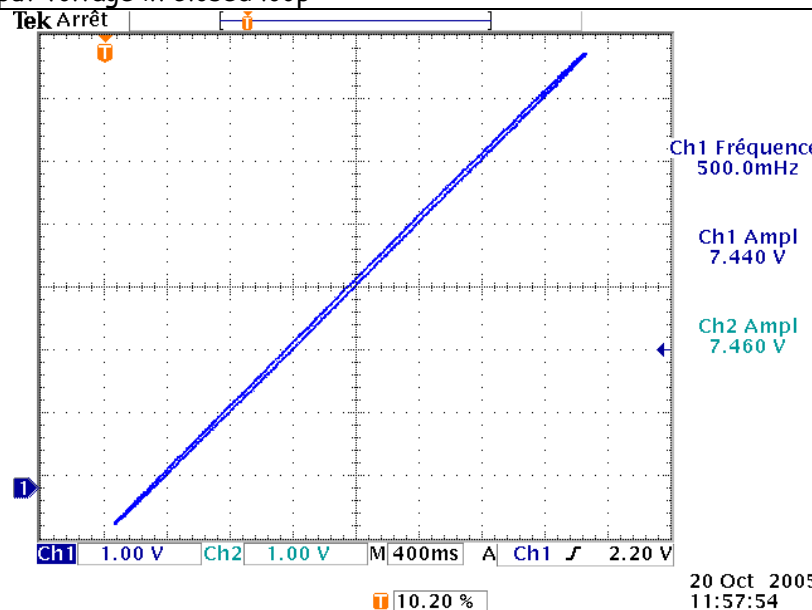



Rack n° 04-00xx

Date of test (DD/MM/YY)

Test performed by

Actuator / electronic channel association

Amplifier channel	SG Channel	Actuator reference
1	1	05-007
2	2	05-008

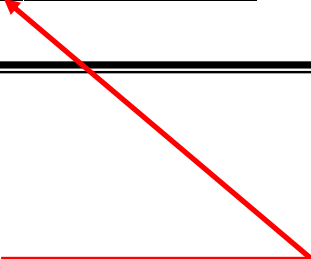

Correspondence between the actuators and the electronic channels

ANNEX 4 : LA75A-X TECHNICAL DATA SHEET ²

Table of standard properties of use and measurement

The properties defined in the table below, are set up according to the technical conditions of use and measurement. These properties are warranted within their variation range and in compliance with the standard technical conditions of use.

Properties LA75A-x	Standard technical conditions	Unit	Nominal values	Min. values	Max. values
Notes			<i>x</i> : number of channel		
Function			Linear amplifier		
Max. number of channels			3		
Cooling			Natural convection (Forced convection for 3 channels)		
Protection			Thermal		
Negative supply voltage	Standard environment	V	-36	-30,0	-40,0
Positive supply voltage	Standard environment	V	165	160,0	180,0
Min. input voltage	Standard environment	V	-1,2	-1,3	-1,1
Max. input voltage	Standard environment	V	7,7	7,6	7,9
Min. output voltage	Standard environment	V	-20	-20,0	-24,0
Max. output voltage	Standard environment	V	150	150,0	156,0
Gain	Standard environment	V/V	20	19,8	20,2
Max. output current		A	0,09	0,09	0,12
Max. output load capacitance		μF	400	360,0	440,0
Signal to noise ratio	Noise measurement conditions	dB	85	70,0	100,0
Unloaded output bandwidth (-3dB)		Hz	33000	29700	36300
Loaded Output bandwidth (-3dB)	Standard load	Hz	154	138,6	169,4
Input impedance		kOhms	10	9,5	10,5
Mass		g	800	-	-
Dimensions		mm	10F wide, 3H high		

Option SC75	Standard technical conditions	Unit	Nominal values	Min. values	Max. values
Notes			Option on amplifier board		
Function			Servo controller		
Signal to noise ratio	Noise measurement conditions	dB	80	68	92
Output bandwidth*		Hz	2000	1800	2200
Accuracy (closed loop)	Standard environment	%	0,1	0,07	0,13

*Bandwidth settled according to your specifications; by default 1 Hz.

² In all CEDRAT TECHNOLOGIES SA documents, the decimal sign is a comma on the line (ISO 31-0:1992).

Properties LC75A	Standard technical conditions	Unit	Nominal values	Min. values	Max. values
Notes			-		
Function			Bipolar AC/DC linear converter		
Cooling			Natural convection		
Protection			Thermal Overcurrent Overvoltage		
Main voltage	Standard main supply	VAC	230	190	250
Main frequency	Standard main supply	Hz	50	45	65
Negative output voltage	Standard environment	VDC	-36	-30,0	-40,0
Positive output voltage	Standard environment	VDC	165	160,0	180,0
Current limitation	Standard environment	A	0,12	0,114	0,126
Mass		g	680	-	-
Dimensions		mm	12F wide, 3H high	-	-
Properties SG75-x	Standard technical conditions	Unit	Nominal values	Min. values	Max. values
Notes			x : number of channel		
Fonction			Strain Gauges conditioner		
Max. number of channels			3		
Min. supply voltage		VDC	-15	-14,3	-15,8
Max. supply voltage		VDC	15	14,3	15,8
Min. output voltage		VDC	-12	-11,4	-12,6
Max. output voltage		VDC	12	11,4	12,6
Signal to noise ratio	Noise measurement conditions	dB	70	56,0	84,0
Output bandwidth (-3dB)*		Hz	2000	1600	2400
Mass		g	150	-	-
Dimensions		mm	6F wide, 3H high		

*Bandwidth settled according to your specifications

Properties standard technical conditions of use and measurement

Quasistatic excitation	: AC voltage between -20 and 150 V at 1 Hz
Environment	: Ambient temperature (15-25°C) and dry air (Humidity < 50 % rH)
Standard main supply	: Main according to directive HD472; could be adapted to 110 VAC on request
Noise measurement conditions	: Excitation 0.5 Vrms ; reading bandwidth 1 Hz to 1 kHz
Standard load	: Actuator APA from series S or SM : 1.55 µF (load test may be different)

Any technical conditions of use, different from those defined above, can lead to temporary or definitive alterations of properties. Thank you to contact CEDRAT TECHNOLOGIES before using actuators under non standard technical conditions.

Factory tests carried out

- Test 1: Load and discharge time
- Test 2: Linearity output voltage vs. input voltage

Extra factory tests

- Test 3: Gain and linearity in closed loop
- Test 4: Step response in closed loop (sensor output voltage versus command voltage)
- Test 5: Thermal test at full load

Available options

- [SC] Servo controller
- [PP] Push-pull

LA75B-x TECHNICAL DATA SHEET

Table of standard properties of use and measurement

The properties defined in the table below, are set up according to the technical conditions of use and measurement. These properties are warranted within their variation range and in compliance with the standard technical conditions of use.

Properties LA75B-x	Standard technical conditions	Unit	Nominal values	Min. values	Max. values
Notes			<i>x : number of channel</i>		
Function			<i>Linear amplifier</i>		
Max. number of channels			2		
Cooling			<i>Natural convection (Forced convection for 2 channels)</i>		
Protection			<i>Thermal</i>		
Negative supply voltage	<i>Standard environment</i>	V	-36	-30,0	-40,0
Positive supply voltage	<i>Standard environment</i>	V	165	160,0	180,0
Min. input voltage	<i>Standard environment</i>	V	-1,2	-1,1	-1,3
Max. input voltage	<i>Standard environment</i>	V	7,7	7,6	7,9
Min. output voltage	<i>Standard environment</i>	V	-20	-20,0	-24,0
Max. output voltage	<i>Standard environment</i>	V	150	150,0	156,0
Gain	<i>Standard environment</i>	V/V	20	19,8	20,2
Max. output current		A	0,36	0,360	0,400
Max. output load capacitance		μ F	400	360,0	440,0
Signal to noise ratio	<i>Noise measurement conditions</i>	dB	85	70,0	100,0
Unloaded output bandwidth (-3dB)		Hz	33000	29700	36300
Loaded Output bandwidth (-3dB)	<i>Standard load</i>	Hz	616	554,5	677,7
Input impedance		kOhms	10	9,5	10,5
Mass		kg	1	-	-
Dimensions		mm	<i>10F wide, 3H high</i>		

Option SC75	Standard technical conditions	Unit	Nominal values	Min. values	Max. values
Notes			<i>Option on amplifier board</i>		
Function			<i>Servo controller</i>		
Signal to noise ratio	<i>Noise measurement conditions</i>	dB	80	68	92
Output bandwidth*		Hz	2000	1800	2200
Accuracy (closed loop)	<i>Standard environment</i>	%	0,1	0,07	0,13

*Bandwidth settled according to your specifications; by default 1 Hz.

Properties LC75B	Standard technical conditions	Unit	Nominal values	Min. values	Max. values
Notes			-		
Function			Bipolar AC/DC linear converter		
Cooling			Forced air		
Protection			Thermal Overcurrent Overvoltage		
Main voltage	Standard main supply	VAC	230	190	250
Main frequency	Standard main supply	Hz	50	45	65
Negative output voltage	Standard environment	VDC	-36	-30,0	-40,0
Positive output voltage	Standard environment	VDC	165	160,0	180,0
Current limitation	Standard environment	A	0,60	0,57	0,63
Mass		g	680	-	-
Dimensions		mm	12F wide, 3H high	-	-
Properties SG75-x	Standard technical conditions	Unit	Nominal values	Min. values	Max. values
Notes			x : number of channel		
Fonction			Strain Gauges conditioner		
Max. number of channels			3		
Min. supply voltage		VDC	-15	-14,3	-15,8
Max. supply voltage		VDC	15	14,3	15,8
Min. output voltage		VDC	-12	-11,4	-12,6
Max. output voltage		VDC	12	11,4	12,6
Signal to noise ratio	Noise measurement conditions	dB	70	56,0	84,0
Output bandwidth (-3dB)*		Hz	2000	1600	2400
Mass		g	150	-	-
Dimensions		mm	6F wide, 3H high		

*Bandwidth settled according to your specifications

Properties standard technical conditions of use and measurement

Quasistatic excitation	: AC voltage between -20 and 150 V at 1 Hz
Environment	: Ambient temperature (15-25°C) and dry air (Humidity < 50 % rH)
Standard main supply	: Main according to directive HD472; could be adapted to 110 VAC on request
Noise measurement conditions	: Excitation 0.5 Vrms ; reading bandwidth 1 Hz to 1 kHz
Standard load	: Actuator APA from series S or SM : 1.55 µF (load test may be different)

Any technical conditions of use, different from those defined above, can lead to temporary or definitive alterations of properties. Thank you to contact CEDRAT TECHNOLOGIES before using actuators under non standard technical conditions.

Factory tests carried out

- Test 1: Load and discharge time
- Test 2: Linearity output voltage vs. input voltage

Extra factory tests

- Test 3: Gain and linearity in closed loop
- Test 4: Step response in closed loop (sensor output voltage versus command voltage)
- Test 5: Thermal test at full load

Available options

- [SC] Servo controller
- [PP] Push-pull

LA75C TECHNICAL DATA SHEET

The properties defined in the table below, are set up according to the technical conditions of use and measurement. These properties are warranted within their variation range and in compliance with the standard technical conditions of use.

Properties LA75C	Standard technical conditions	Unit	Nominal values	Min. values	Max. values
Notes			-		
Function			Linear amplifier		
Max. number of channels			1		
Cooling			Forced air		
Protection			Thermal Short circuit		
Negative supply voltage	Standard environment	V	-36	-30,0	-40,0
Positive supply voltage	Standard environment	V	165	160,0	180,0
Min. input voltage	Standard environment	V	-1,2	-1,1	-1,3
Max. input voltage	Standard environment	V	7,7	7,6	7,9
Min. output voltage	Standard environment	V	-20	-20,0	-24,0
Max. output voltage	Standard environment	V	150	150,0	156,0
Gain	Standard environment	V/V	20	19,8	20,2
Max. output current		A	2,40	2,30	2,50
Max. output load capacitance		μF	400	360,0	440,0
Signal to noise ratio	Noise measurement conditions	dB	85	70,0	100,0
Unloaded output bandwidth (-3dB)		Hz	33000	29700	36300
Loaded Output bandwidth (-3dB)	Standard load	Hz	4107	3697	4518
Input impedance		kOhms	10	9,5	10,5
Mass		g	860	-	-
Dimensions		mm	18F wide, 4H high		

Option SC75	Standard technical conditions	Unit	Nominal values	Min. values	Max. values
Notes			Option on amplifier board		
Function			Servo controller		
Signal to noise ratio	Noise measurement conditions	dB	80	68	92
Output bandwidth*		Hz	2000	1800	2200
Accuracy (closed loop)	Standard environment	%	0,1	0,07	0,13

*Bandwidth settled according to your specifications; by default 1 Hz.

Properties LC75C	Standard technical conditions	Unit	Nominal values	Min. values	Max. values
Notes			-		
Function			Bipolar AC/DC linear converter		
Cooling			Forced air		
Protection			Thermal Overcurrent Overvoltage		
Main voltage	Standard main supply	VAC	230	190	250
Main frequency	Standard main supply	Hz	50	45	65
Negative output voltage	Standard environment	VDC	-36	-30,0	-40,0
Positive output voltage	Standard environment	VDC	165	160,0	180,0
Current limitation	Standard environment	A	2,40	2,28	2,52
Mass		g	680	-	-
Dimensions		mm	12F wide, 3H high	-	-
Properties SG75-x	Standard technical conditions	Unit	Nominal values	Min. values	Max. values
Notes			x : number of channel		
Fonction			Strain Gauges conditioner		
Max. number of channels			3		
Min. supply voltage		VDC	-15	-14,3	-15,8
Max. supply voltage		VDC	15	14,3	15,8
Min. output voltage		VDC	-12	-11,4	-12,6
Max. output voltage		VDC	12	11,4	12,6
Signal to noise ratio	Noise measurement conditions	dB	70	56,0	84,0
Output bandwidth (-3dB)*		Hz	2000	1600	2400
Mass		g	150	-	-
Dimensions		mm	6F wide, 3H high		

*Bandwidth settled according to your specifications

Properties standard technical conditions of use and measurement

Quasistatic excitation	: AC voltage between -20 and 150 V at 1 Hz
Environment	: Ambient temperature (15-25°C) and dry air (Humidity < 50 % rH)
Standard main supply	: Main according to directive HD472; could be adapted to 110 VAC on request
Noise measurement conditions	: Excitation 0.5 Vrms ; reading bandwidth 1 Hz to 1 kHz
Standard load	: Actuator APA from series S or SM : 1.55 µF (load test may be different)

Any technical conditions of use, different from those defined above, can lead to temporary or definitive alterations of properties. Thank you to contact CEDRAT TECHNOLOGIES before using actuators under non standard technical conditions.

Factory tests carried out

- Test 1: Load and discharge time
- Test 2: Linearity output voltage vs. input voltage

Extra factory tests

- Test 3: Gain and linearity in closed loop
- Test 4: Step response in closed loop (sensor output voltage versus command voltage)
- Test 5: Thermal test at full load

Available options

- [SC] Servo controller
- [PP] Push-pull

CA45 TECHNICAL DATA SHEET

Table of standard properties of use and measurement

The properties defined in the table below, are set up according to the technical conditions of use and measurement. These properties are warranted within their variation range and in compliance with the standard technical conditions of use.

Properties CA45	Standard technical conditions	Unit	Nominal values	Min. values	Max. values
Notes			-		
Function			Standalone voltage amplifier		
Cooling			Natural convection		
Protection			Thermal Overcurrent Overvoltage		
Main voltage	Standard main supply	VAC	230	190,0	250,0
Main frequency	Standard main supply	Hz	50	45,0	65,0
Min. input voltage	Standard environment	V	-1,2	-1,5	-1,2
Max. input voltage	Standard environment	V	7,7	7,7	7,9
Min. output voltage	Standard environment	V	-20	-20,0	-25,0
Max. output voltage	Standard environment	V	150	150,0	160,0
Gain	Standard environment	V/V	20	19,8	20,2
Max. output current		A	0,03	0,030	0,045
Max. output load capacitance		µF	400	360,0	440,0
Signal to noise ratio	Noise measurement conditions	dB	85	80,0	90,0
Unloaded output bandwidth (-3dB)		Hz	10000	9000	11000
Loaded Output bandwidth (-3dB)	Standard load	Hz	154	154,0	169,4
Input impedance		kOhms	10	9,5	10,5
Mass		g	1200	-	-
Dimensions		mm	12F wide, 3H high		

Option SG	Standard technical conditions	Unit	Nominal values	Min. values	Max. values
Notes			Option on amplifier board		
Function			Servo controller		
Signal to noise ratio	Noise measurement conditions	dB	85	80	90
Output bandwidth*		Hz	2000	1800	2200
Accuracy (closed loop)		%	0,1	0,07	0,13

Option ECS	Standard technical conditions	Unit	Nominal values	Min. values	Max. values
Notes			Option on amplifier board		
Function			Servo controller		
Signal to noise ratio	Noise measurement conditions	dB	100	85	100
Output bandwidth*		Hz	10000	9000	11000
Accuracy (closed loop)		%	0,01	0,007	0,013

*Bandwidth settled according to your specifications; by default 1 Hz.

Properties standard technical conditions of use and measurement

Quasistatic excitation	: AC voltage between -20 and 150 V at 1 Hz
Environment	: Ambient temperature (15-25°C) and dry air (Humidity < 50 % rH)
Standard main supply	: Main according to directive HD472; could be adapted to 110 VAC on request
Noise measurement conditions	: Excitation 0.5 Vrms ; reading bandwidth 1 Hz to 1 kHz
Standard load	: Actuator APA from series S or SM : 1.55 µF (load test may be different)

Any technical conditions of use, different from those defined above, can lead to temporary or definitive alterations of properties. Thank you to contact CEDRAT TECHNOLOGIES before using actuators under non standard technical conditions.

Factory tests carried out

- Test 1: Load and discharge time
- Test 2: Linearity output voltage vs. input voltage

Extra factory tests

- Test 3: Gain and linearity in closed loop
- Test 4: Step response in closed loop (sensor output voltage versus command voltage)
- Test 5: Bode diagram

Available options

- [SC] Servo controller
- [PP] Push-pull

TECHNICAL DATA SHEET

CA45

v3.1

➤ PROPERTIES STANDARD TECHNICAL CONDITIONS OF USE AND MEASUREMENT

Quasi-static excitation	: AC voltage between -20 and 150 V at 1 Hz
Environment	: Ambient temperature (15-25°C) and dry air (Humidity < 80% rH)
Standard main supply	: Main according to directive HD472; could be adapted to 110 VAC on request
Noise measurement conditions	: Excitation 0.5 Vrms ; reading bandwidth 1 Hz to 1 kHz
Standard load	: Actuator APA from series S or SM : 1.65 μ F (load test may be different)

Any technical conditions of use, different from those defined above, can lead to temporary or definitive alterations of properties. Thank you to contact CEDRAT TECHNOLOGIES before using actuators under non standard technical conditions.

➤ FACTORY TESTS CARRIED OUT

- Test 1: Load and discharge time
- Test 2: Linearity output voltage vs. input voltage

➤ EXTRA FACTORY TESTS

- Test 3: Gain and linearity in closed loop
- Test 4: Step response in closed loop (sensor output voltage versus command voltage)
- Test 5: Bode diagram

➤ AVAILABLE OPTIONS

- [SC] Servo controller
- [FP] Push-pull

ANNEX 4 : TROUBLE SHOOTING FORM

In case of trouble or breakdown with the electronic device, this form must be completed by the customer in order to :

- allow Cedrat Technologies to authorise the product return back to the factory,
- help Cedrat Technologies in repairing it.

Product: Please give mention here the references and delivery date,

History: Please summarise here every action which has been performed with the device since the delivery,

Problem description: Please describe here the problems faced with the electronics and which are not described in the paragraph 7,

Notations: Please define here the short term used for external devices plugged in the electronics in order to make the writing of "problem identification" easier,

Problem identification: Please summarise and describe here, using the "notations", the operation that could lead to problem identification,

Action: Please mention and update here every action undertaken by yourself, by Cedrat Technologies or by your local vendor,

Please note that you need to get the authorisation from CEDRAT TECHNOLOGIES before sending back the hardware.